

new product
information

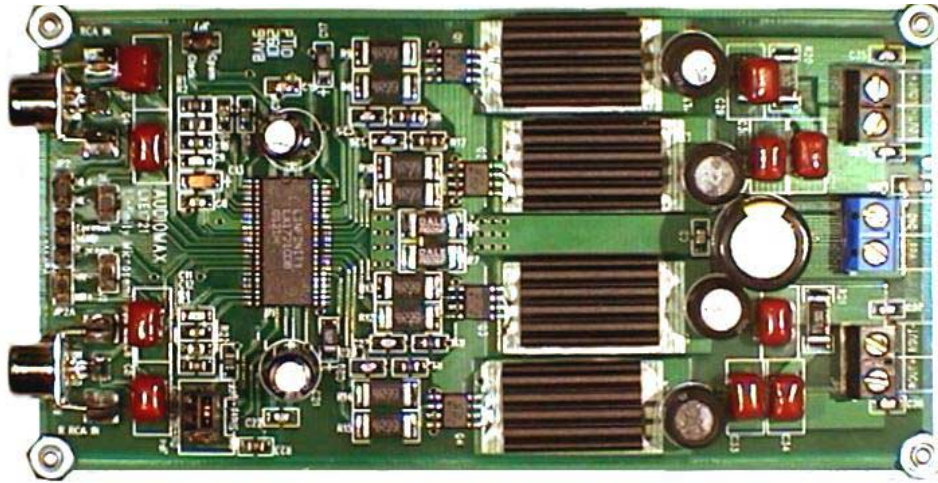

LX1721/1722 AUDIOMAX™ CLASS-D STEREO POWER AMPLIFIER CONTROLLER

New Product Information and Sales Kit

Manufactured by:

Microsemi Linfinity
Garden Grove

Telephone: (714) 898-8121

www.Microsemi.com

More than solutions – enabling possibilities

TABLE OF CONTENTS

INTRODUCTION

Description3

KEY PRODUCT INFORMATION

Block Diagram4
Key Features5
Applications5
Typical Application.....6

COMMON QUESTIONS

Amplifier Power7

COMPETITIVE ANALYSIS

Class-D vs. Linear8
All Digital Amplifiers.....9
Analog Input Amplifiers.....10
Competition Summary Table12

SALES STRATEGY

Positioning15

SUMMARY

Pricing16
Availability16
Options16
Technical Support.....16
Factory Contacts16

CONFIDENTIAL INFORMATION

This new product introduction guide is intended for use only by Microsemi's sales people and authorized representatives and distributors. This material can be adapted for customer presentations, but the sales strategy and summary [pricing, availability, etc.] is confidential and should not be shown to customers.

INTRODUCTION

DESCRIPTION

The LX1721/1722 is a high performance Class-D Stereo Controller IC targeted for high efficiency audio requirements such as battery powered products, portable systems, or space constrained applications. Other ideal end products that can utilize Class-D switching technology include automotive amplifiers, multi-channel multimedia computers, and video game systems where maximum power density (output power per circuit area) is beneficial.

The full audio bandwidth amplifier controller offers dramatically improved performance over Linfinity's previous generation amplifier products. Enhancements include higher output power, better SNR, lower noise floor, and reduced THD. Combined with output power MOSFET's and an output filter, the LX1721/1722 is a complete Class-D audio solution. The LX1721/1722 is available in a space saving 44-pin QSOP package.

The LX1722 is the high power version controller ($>65W_{rms}$, 4Ω) with a supply voltage range of 7V-25V and the LX1721 is the high fidelity version (better SNR performance) with a supply voltage range of 7V-15V. The current rating of the external MOSFET's, the available supply voltage, and speaker load primarily determines the maximum output power.

Complete audio amplifier modules (LXE1721 or LXE1722) are available to quickly evaluate the LX1721 or LX1722 stereo controller. Other reference designs are available to support a variety of requirements including multi channel systems, powered subwoofers, satellite/subwoofer combination products and various speaker loads (2Ω , 4Ω , 8Ω). The versatile amplifier solution can easily be adjusted for frequency response, optimized for efficiency and performance, or designed to minimize PCB area and component count.

The amplifier provides high fidelity performance and is designed to operate over the full 20Hz to 20kHz audio band. Signal distortion measurements yield THD+N levels of 0.06%(1kHz, 1Wrms). Efficiency is greater than 80% typical, which eliminates the need for heatsinks in most applications. The AudioMAX™ solution requires a single supply voltage, simplifying input power requirements.



KEY PRODUCT INFORMATION

BLOCK DIAGRAM

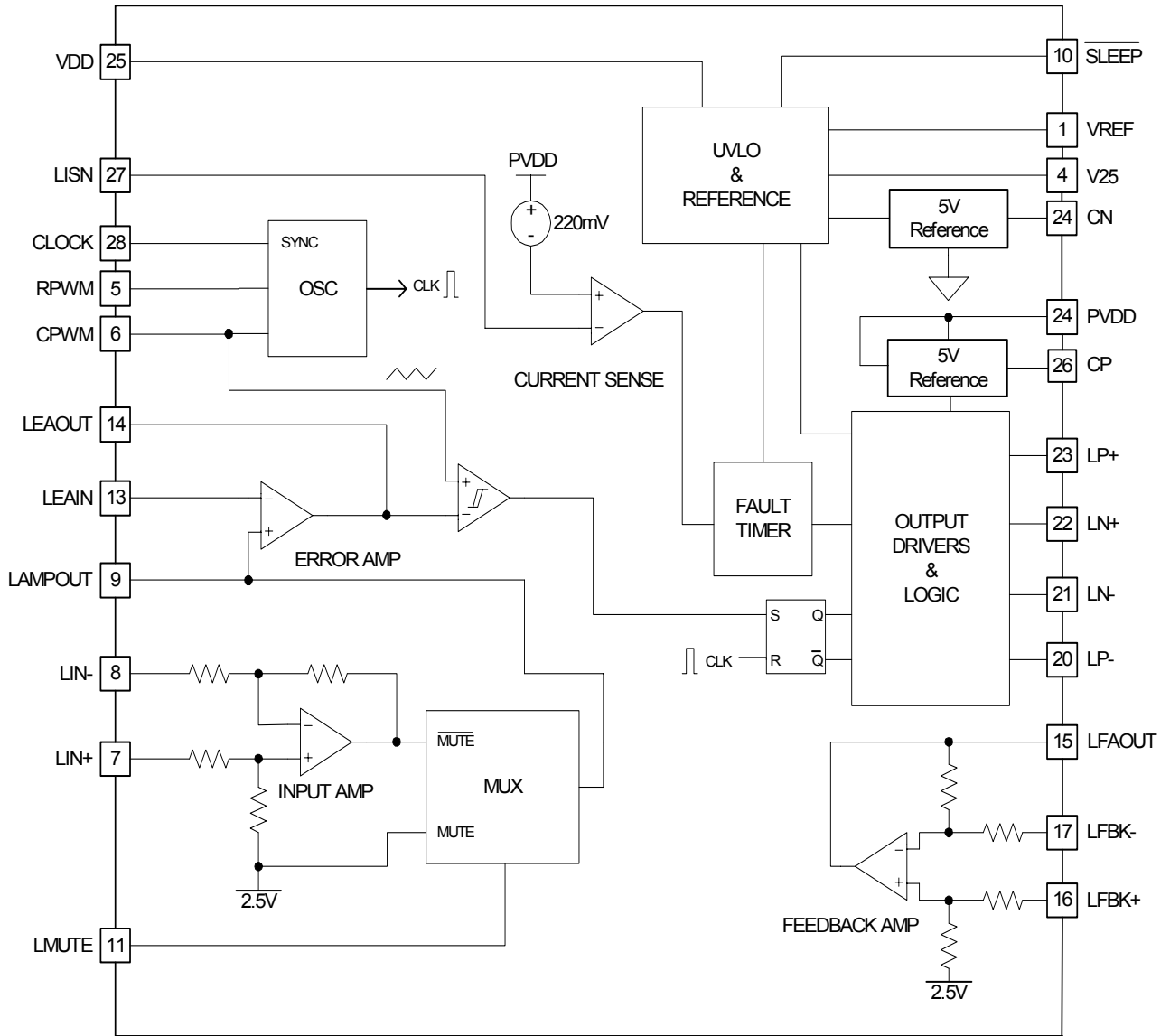

LX1721/1722 Simplified Block Diagram (Left Channel Circuit Shown)

KEY FEATURES

- Integrated Switching Class-D Stereo Controller IC
- Supports Full 20Hz-20kHz Audio Bandwidth
- High Fidelity (LX1721) Or High Power (LX1722) Versions Available
- Single Supply Operation
- THD+N <0.06% Typical (1Wrms, 1kHz, 4Ω)
- Maximum Efficiency 80%-85%
- Output Power >60Wrms per Channel (LX1722, 4Ω, 1% THD+N)
- PSRR -70dB Typical
- Differential Input To Minimize Noise Effects
- Synchronization to Support Multi-Channel Systems
- Complete LXE1721 or LXE1722 Amplifier Evaluation Modules Available
- 44-Pin QSOP Package

APPLICATIONS

- Multimedia Speakers
- Surround Sound Game Systems
- Automotive Amplifiers And Head Units
- Wireless Speakers
- Desktop Computers
- Battery Operated Equipment (Megaphone, Public Address System)
- Portable Audio (Boom Box)
- High Power Subwoofer
- Notebook Computers
- Home Theatre

TYPICAL APPLICATION

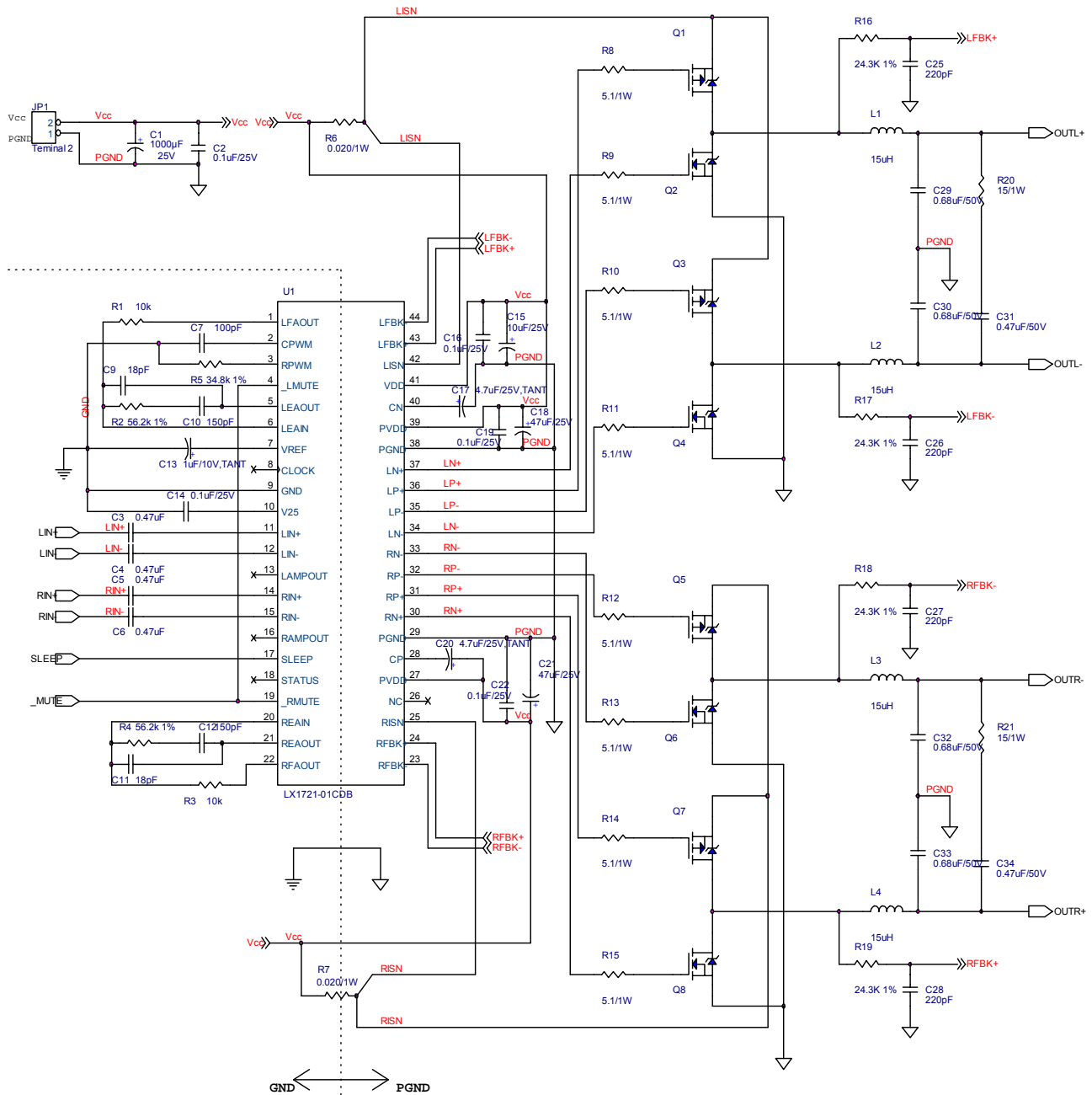

Typical LX1721 Class-D Stereo Circuit

COMMON QUESTIONS

HOW MUCH POWER CAN THIS AMPLIFIER DELIVER?

Since the LX1721/1722 are Class-D controllers, the maximum output power is virtually unlimited and primarily a function of the current rating of the external MOSFET's, the available supply voltage, and the speaker load. The following output power values (derived from Audio Precision Plots contained in the datasheet) are shown for various loads and supply voltages at <1% THD+N, 1kHz.

V_{DD}	Load (Ω)	Output Power (typical W_{rms})
15V	4 Ω	25W
15V	2 Ω	42W
25V	4 Ω	63W
25V	2 Ω	110W*

*Care must be exercised to provide adequate thermal conductivity.

In the world of audio amplifiers, POWER sells and consumers typically want “as many watts as possible”. Be cautious when comparing power specifications or discussing output power capability. Although power rating standards have been established such as FTC (Federal Trade Commission) or EIA (Electronic Industries Association), the customer’s end product specifications do not always follow these guidelines. The “watts per channel” number might be “peak” power, “music” power, or “peak music power output” (PMPO) which are inflated marketing numbers over their true W_{rms} capability. Furthermore, conditions such as distortion level, input frequency band, and filter range should be specified.

COMPETITIVE ANALYSIS

There are many competitors in the audio controller marketplace. Some suppliers such as National, Philips, STMicroelectronics, or Texas Instruments have supplied audio products for many years. Recently, Cirrus Logic and Maxim have also announced Class-D products. The increase in new competition as well as the emerging consumer awareness, value placed on audio, and desire for better audio content are indications of the broad and growing audio market.

The Microsemi LX1721/1722 amplifier controllers are uniquely positioned to provide the optimum tradeoff between cost and performance. No other Class-D products support the “medium” output power levels for performance and price.

CLASS-D VS. LINEAR AMPLIFIERS

The primary benefit of Class-D technology compared to linear amplifiers is better efficiency. This equates to extended battery life, ability to use a smaller power supply, or utilization of a reduced PCB/system area. Linear solutions like many of National Semiconductor’s Boomer® products or the Texas Instruments product line are simple, low cost amplifiers but are limited to low power applications (typically 1W-2W) and do not have the efficiency of the switching techniques inherent to Class-D. The other end of the audio spectrum is for high power and high performance which has also been supported by linear type solutions for high-end audiophile or studio applications. Passionate Audiophiles may be reluctant to adopt Class-D technology. The table below summarizes the tradeoffs.

<i>(Single Channel)</i>	Linear	Class-D
Efficiency	50%-60%	80%-90%
PCB area	Requires Heatsink	Optional
# of Components	10-15	35-45
Costs*	\$0.30-\$0.80 IC	\$1.50-\$2.00 IC
Other Issues	Needs “larger” Power Supply	Potential EMI

*Approximate costs of low power linear controller



COMPLETE DIGITAL CLASS-D AMPLIFIERS

Many players (like Microsemi) in the Class-D arena including Maxim, National, STMicroelectronics, TI, Tripath, and Zetex (Oldham, UK) support an analog audio input source. Several other manufacturers have been promoting "all digital" amplifier solutions. In general, these "all digital" solutions are receiving increased interest but are currently quite expensive solutions. Several customers have stated that some applications will require all digital but some will prefer the simple and cost effective analog input approach, especially during this transition where analog still needs to be supported.

Apogee (Norwood, MA)

Apogee has signed an exclusive license with STMicroelectronics for its Direct Digital Amplification all digital amplifier technology. The DDX-2000 controller and DDX-2060 power device are an amplifier chip set solution which support an I2S input. The DDX-4100 is a controller IC that converts digital audio inputs into 4.1 channels of DDX outputs to drive their DDX-2060 device. I2S, SPDIF, and AC'97 input interfaces are supported.

Cirrus Logic (Austin, TX)

The Crystal CS44L10 is a stereo digital-to-PWM class-D headphone amplifier including digital volume/tone control and also takes a serial audio input (I2S). The Crystal CS 44210 is used in conjunction with a gate driver IC from IR (IRCS8001) and the power MOSFETs (IRCS8102) for their 50W unbridged multi channel or 200W bridged mono amplifier solution.

Pulses (Seoul, Korea)

The PS9602, PS9604, and PS9702 are a family of stereo PCM to PWM converter IC's (28-QFP, 44-QFP) used as the core component of a digital amplifier.

TI/Toccatà Technology

Texas Instruments has a complete digital solution comprising of the TAS50xx family (TAS5000, TAS5001, TAS5012, TAS5015) which are digital audio PWM processors and the TAS51xx family (TAS5100, TAS5110) which are the amplifier power stage.



LX1721/1722 vs. OTHER “ANALOG INPUT” CLASS-D AMPLIFIERS

Tripath (Santa Clara, CA)

In the medium power level, the Tripath TA2020 is the main amplifier that competes with the LX1721/1722. Tripath has been promoting their “Class-T” audio products for a few years and claim to have solutions that meet ALL applications (high end/low end, high power/low power, PC low end to home theater). Although they had design wins with Sony (combo home DVD system) and Apple (G4 cube), they have continued to lose money every quarter and their stock price is down 98% over the past year. Their Chip Solution products are divided up into:

- High Power Products: The TA10xA and TA3020 are driver hybrids which must be combined with external FETS and require multiple supply voltages. They are packaged in 38 or 48-pin modules consisting of a CMOS signal processor and two DMOS drivers. Pricing has been in the \$20 range.
- High Integration Products: The TA1101 and TA202x amplifiers have the driver and the FET in a single package. Pricing has been in the \$6 to \$15 range.

The Microsemi LX1721/1722 have some key advantages over the Tripath TA2020-020.

	Microsemi LX1722	Tripath TA2020-020	Key Advantages
Max V _{DD}	25V	13.5V	LX1722 can easily be used for 50-60Wrms amplifier designs. Tripath limitation of 13.5V will only support approximately 20Wrms output power.
Frequency	250kHz-500kHz programmable	1MHz	The Tripath 1MHz operating frequency interferes with the AM band, poses potentially more EMI radiation problems, and lower efficiency.
Efficiency	80-85%	88%?	Lab evaluation of the TA2020 was 70% or lower.
FETs/Cost	Need external	Integrated	Even though Tripath has integrated FETs, the cost of a LX1722 plus 4 dual FETs is no greater than a TA2020.

LX1721/1722 vs. OTHER “ANALOG INPUT” CLASS-D AMPLIFIERS (CONT.)



In general, the following Class-D products from other manufacturers cannot support the output power levels like the LX1721 or LX1722. See the table below for complete information.

Maxim

Maxim has developed mono and stereo 2W class-d amplifiers for the portable market. Evaluation boards are available but limited to low power applications.

National Semiconductor

The National Boomer[®] product line is widely recognized and established in the low power area. The LM4663 is their stereo class-d which is limited to 2W typical (4Ω, 5V, 1% THD). They also have a LM4651/52 which is a 170W chip set (PWM driver IC and quad MOSFET) targeted for subwoofer applications.

STMicroelectronics

The TDA748x mono class-d products are low cost/low performance and require a split power supply. They are targeted for TV and limited home stereo designs. STMicro has announced the TDA7490/7490L which are 25W/15W stereo amplifiers.

Texas Instruments

TI offers many audio products (up to their third generation) primarily targeted to the lower power hand held, portable market. The stereo and mono IC's support limited output power typically in the 1-2W range with some up to 10W typical but cannot provide the power levels of the LX1721/1722.

Zetex (Oldham, England)

Zetex has announced a ZXCD1000 and a ZXCD1001 which are 25W (don't specify the conditions) mono class-d controllers.

COMPETITION SUMMARY TABLE

	Part #	Description	Output Power (W)	Output Power (W)	Supply Voltage (V)	THD + N (%)	Efficiency (%)	Package	Price 1k
Apogee	DDX-2000	Direct Digital Amplification Controller						44-PQFP	\$6.98 chip set
	DDX-2060	Direct Digital Amplification Power Device						36-Power	
Cirrus	CS44L10	True Digital PWM Class-D Headphone Amp	<1		2.4-5.0			16 TSSOP	\$2.81 (10k)
	CS44210	True Digital Class-D Amplifier with Headphone	50, 200				>90	24 TSSOP	\$3.95 (10k)
Intersil (Harris)	Cool Audio		125-220						
Maxim	MAX4295	Mono Class-D	2 typ (4 ohm, 5V), 1.2 typ (8 ohm, 5V)	.7 typ (4 ohm, 3V), .4 typ (8 ohm, 3V)	2.7-5.5	0.4 typ (1W, 1kHz)	87 (2W)	16 QSSOP/16 Narrow SO	\$1.45
	MAX4297	Stereo Class-D	2 typ (4 ohm, 5V), 1.2 typ (8 ohm, 5V)	.7 typ (4 ohm, 3V), .4 typ (8 ohm, 3V)	2.7-5.5	0.4 typ (1W, 1kHz)	87 (2W)	24 SSOP/24 Wide SO	\$2.45
MPS	MP7501	Class-D Audio Amp	15 (18V)		5.5-22		95	8 SOIC, 8 DIP	
National	LM4663	Stereo Class-D with Headphone	2.1 typ (4 ohm, 5V, <1%)	80mW typ headphone (32 ohm, 5V)	4.5-5.5	0.2 typ (1W, 1kHz)	83 (2W)	24 TSSOP	\$2.35
	LM4900, LM4892, LM4819, LM4809, LM4810	Boomer Audio Amplifiers	.3 (8 ohm, 5V, 10%)		2			8 MSOP/micro SMD/SOIC	\$.50, .85, .19, .17, .17



COMPETITION SUMMARY TABLE (CONT.)

	Part #	Description	Output Power (W)	Output Power (W)	Supply Voltage (V)	THD + N (%)	Efficiency (%)	Package	Price 1k
STMicro	TDA7480	Mono Class-D	7 (1%), 10 (10%)		+/- 10 to +/- 16	10 (10W), 0.1 (.5W)		20 PDIP	
	TDA7481	Mono Class-D	18 (10%)		+/- 10 to +/- 25	10 (18W)			
	TDA7482	Mono Class-D	25 (10%)			10 (25W)			
	TDA7490	Stereo Class-D	25/ch		+/- 10 to +/- 25			25 Flexiwatt	
	TDA7490L	Stereo Class-D	15/ch					25 Flexiwatt	
Tripath	TA1101B	Stereo Class-T	2x10 typ (4 ohm, 12V, .1%), 6 typ (8 ohm)	15 typ (4 ohm, 12V, 10%), 9.5 typ (8 ohm)	8.5-13	0.04 typ (4W), 0.08 max	88	30 PSOP	
	TA2020	Stereo Class-T	2x20 typ/ch		13.5	5 (2x20), .03 (2x10)	88	32 SSIP	\$16.00
	TA2022	Stereo Class-T	2x100		+/- 35		90	32 SSIP	
	TA0102A, 103A, 104A	Stereo Class-T Amplifier Drivers	2x150, 2x250, 2x500		+/-28 to +/- 92		90	38 DIP Module	
	TA3020	Stereo Class-T Amplifier Driver	2x350		+/-15 to +/- 65		95	48 DIP Module	
Zetex	ZXCD1000	Mono Class-D	25		12-18	<.2 (90% power, audioband), <.1 (1kHz)	90	16 eQSOP	
	ZXCD1001	Advanced Mono Class-D	25		12-18				



COMPETITION SUMMARY TABLE (CONT.)

	Part #	Description	Output Power (W)	Output Power (W)	Supply Voltage (V)	THD + N (%)	Efficiency (%)	Package	Price 1k
TI 3rd Generation 1&2W)	TPA2001D2	Stereo Filterless Class-D	1 typ (8 ohm, 5V, 0.4%)		4.5-5.5	<0.2 typ (0.5W, audioband)	75-85	24 TSSOP	\$1.69
	TPA2001D1	Mono Filterless Class-D	1 typ (8 ohm, 5V, 1%, 1kHz)	.40 typ (8 ohm, 3.3V, 1%)	2.7-5.5	<0.1 typ (1W, audioband)	75-85	16 TSSOP, BGA	\$0.78
	TPA2000D4	Stereo Class-D with Headphone	2 typ (4 ohm, 5V, 0.1%, 1kHz)	90mW typ headphone (32 ohm, 5V, 0.1%, 1kHz)	3.7-5.5	<0.4 typ (1W, audioband)		32 TSSOP	\$2.06
	TPA2000D2	Stereo Filterless Class-D	2 typ (3 ohm, 5V, 0.1%)		4.5-5.5	<0.5 typ (1W, audioband)	70-85	24 TSSOP	\$1.88
	TPA2000D1	Mono Filterless Class-D	2 typ (4 ohm, 5V, 1%, 1kHz)	.85 typ (4 ohm, 3.3V, 1%)	2.7-5.5	<0.2 typ (1.5W, audioband)	75-85	16 TSSOP, BGA	\$1.14
TI 2nd Generation 10W	TPA032D04	Stereo Class-D with AB Headphone	10 typ (4 ohm, 12V, 0.5%)	50mW typ headphone (32 ohm, 5V)	8-14, 4.5-5.5	0.5	77	48 TSSOP	\$5.39
	TPA032D03	Mono Class-D with AB Headphone	10 typ (4 ohm, 12V, 0.5%)	7.5 typ (8 ohm, 12V, 0.5%)	8-14, 4.5-5.5	0.5	77	48 TSSOP	\$4.90
	TPA032D02	Stereo Class-D	10 typ (4 ohm, 12V, 0.5%)	7.5 typ (8 ohm, 12V, 0.5%)	8-14, 4.5-5.5	0.5	77	48 TSSOP	\$5.16
	TPA032D01	Mono Class-D	10 typ (4 ohm, 12V, 0.5%)	7.5 typ (8 ohm, 12V, 0.5%)	8-14, 4.5-5.5	0.5	77	48 TSSOP	\$4.48
TI 1st Generation 2W	TPA005D14	Stereo Class-D with AB Headphone	2 typ (4 ohm, 5V, 0.5%)		4.5-5.5	0.2 typ (1W, 1kHz)	80	48 TSSOP	\$3.79
	TPA005D12	Stereo Class-D	2 typ (4 ohm, 5V, 0.5%)		4.5-5.5	0.2 typ (1W, 1kHz)	80	48 TSSOP	\$3.48
	TPA005D02	Stereo Class-D	2 typ (4 ohm, 5V, 0.5%)		4.5-5.5	0.2 typ (1W, 1kHz)	80	48 TSSOP	



Alternative Microsemi Solutions

Device	Description	Notes
LX1710	15V, Mono Class-D	<ul style="list-style-type: none"> The LX1710 is the mono version with similar performance and power levels to the LX1721.
LX1711	25V, Mono Class-D	<ul style="list-style-type: none"> The LX1711 is the mono version with similar performance and power levels to the LX1722.

SALES STRATEGY

Identify accounts or products that utilize an external speaker for music, sound, or voice that will benefit from a HIGH EFFICIENCY audio amplifier.

- Think high efficiency, lower power dissipation, less heat, for more audio output power. It is very easy to identify end-products that use audio. Focus on the applications that will benefit from extended battery playtime, or have a small system form factor requirement. Many other products can benefit from improved efficiency, not just battery powered systems. Applications that have a limited volume (length x width x height) “box” (like a speaker enclosure or the system unit) that houses the amplifier have utilized Microsemi’s Class-D technology.
- Sell the entire system solution and overall system cost savings. The size (wattage) and cost of the power supply can be reduced compared to a linear amplifier. Further cost savings or reductions might be realized from eliminating the heat sink or making other mechanical system changes.
- Promote the ease of use with simplified reference circuits and evaluation boards. The versatile amplifier supports a wide range of power levels with several evaluation boards to quickly get started.

Positioning

- The LX1721/1722 uniquely fulfill the class-d “mid-watts-level” area with the most output power for the dollar. Reference designs are also available to support higher power needs greater than 100Wrms. These higher power requirements can utilize a simple buffer, FET driver circuit.
- This traditional, simple class-d approach offers the best performance/cost available and provides a high quality amplifier for many applications.



SUMMARY

Pricing

AudioMAX Controllers	Package	Commercial (0 to 70°C)	
		DC	1000+
LX1721CDB (7V-15V)	44-pin QSOP	\$4.61	\$5.32
LX1722CDB (7V-25V)	44-pin QSOP	\$4.61	\$5.32
Note: add \$0.03 for tape and reel			
AudioMAX Evaluation Boards	Package	Commercial (0 to 70°C)	
		DC	Resale
LXE1721 Evaluation Board	PCB with connectors	\$67.00	\$83.75
LXE1722 Evaluation Board	PCB with connectors	\$78.64	\$98.30

Availability

Samples:	LX1721CDB:	NOW
	LX1722CDB:	NOW
	LXE1721:	NOW
	LXE1722:	October 2001
Production:	All:	October 2001

Options

Packages:	DB	QSOP [44-pin]	Tape and reel [MOQ 1000pcs]
Temperature:	C	Commercial	0 to 70°C

Technical Support

Datasheet:	LX1721/1722
Application Note:	See LXE1710 User Guide for other circuit information
Evaluation Board:	LXE1721, LXE1722

Factory Contacts

Technical Questions:	Beau Brown (714) 372-8419 bbrown@microsemi.com
Marketing Manager:	Mike Tanaka (714) 372-8302 mtanaka@microsemi.com