

# SYNCHRONOUS BUCK CONVERTER LX1918 EVALUATION BOARD

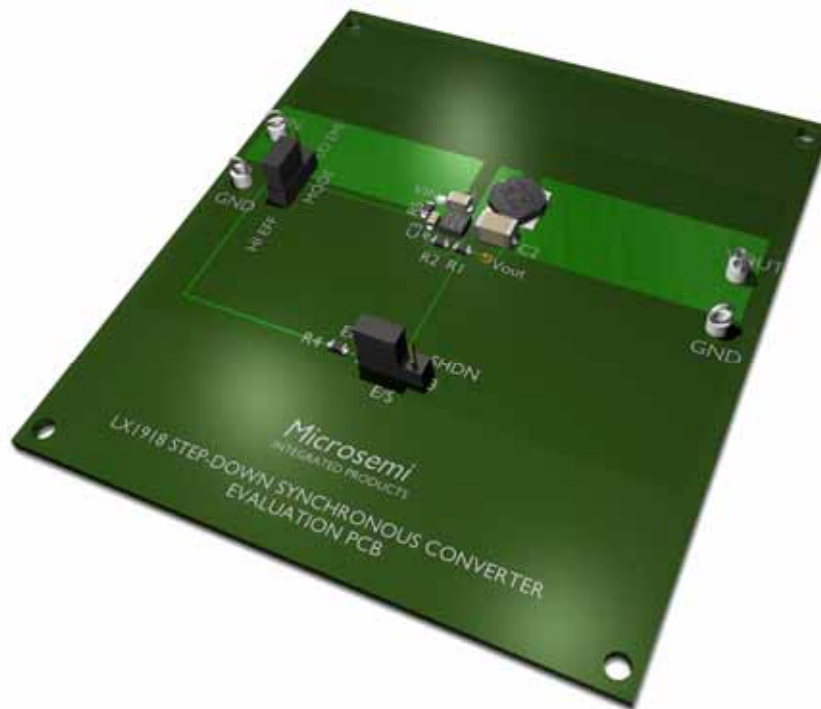

**TABLE OF CONTENTS**

LX1918 EVAL Introduction ..... 3  
Schematic for LX1918 Evaluation Board ..... 4  
Hook Up ..... 5  
Connections ..... 6  
Bill of Materials ..... 6

## INTRODUCING TO PRODUCT

The LX1918 Evaluation Board is available from Microsemi for demonstrating the performance of the LX1918 Synchronous Buck Converter.

## KEY FEATURES

- 2.7V to 6.0V Input Range
- 1.5A Output Current
- 1Mhz free running or 500KHz to 1.25MHz Switching Frequency
- 0.6V Reference Voltage Adjustment
- PFM or PWM Mode
- EMI Support With Force PWM Mode
- Light Load Support:  $I_{OUT} < 300mA$
- $> 95\%$  Efficiency
- Quiescent Current Typical  $400\mu A$
- No External Schottky Diode
- Thermal Shutdown
- Cycle By Cycle Switch Current Limit
- UVLO Protection
- Current Limiting in Hiccup Mode
- 8-Pin MLP package ( $3mm^2$ )

## APPLICATIONS

- Lower Power Embedded Applications
- WLAN Power Systems
- Portable Design with Single Cell Lilon or 3 Cell NiMH / NiCd
- Low Power Portable Storage Application

## PART SPECIFIC INFORMATION

Part Number	Description
LX1918CLD	1.5A Step-Down Synchronous Converter

TABLE 1 – PART INFORMATION

IC	EVALUATION BOARDS
LX1918CLD	LX1918-LD EVAL

TABLE 2 – EVALUATION BOARD INFORMATION

**SCHEMATIC FOR LX1918 EVAL**

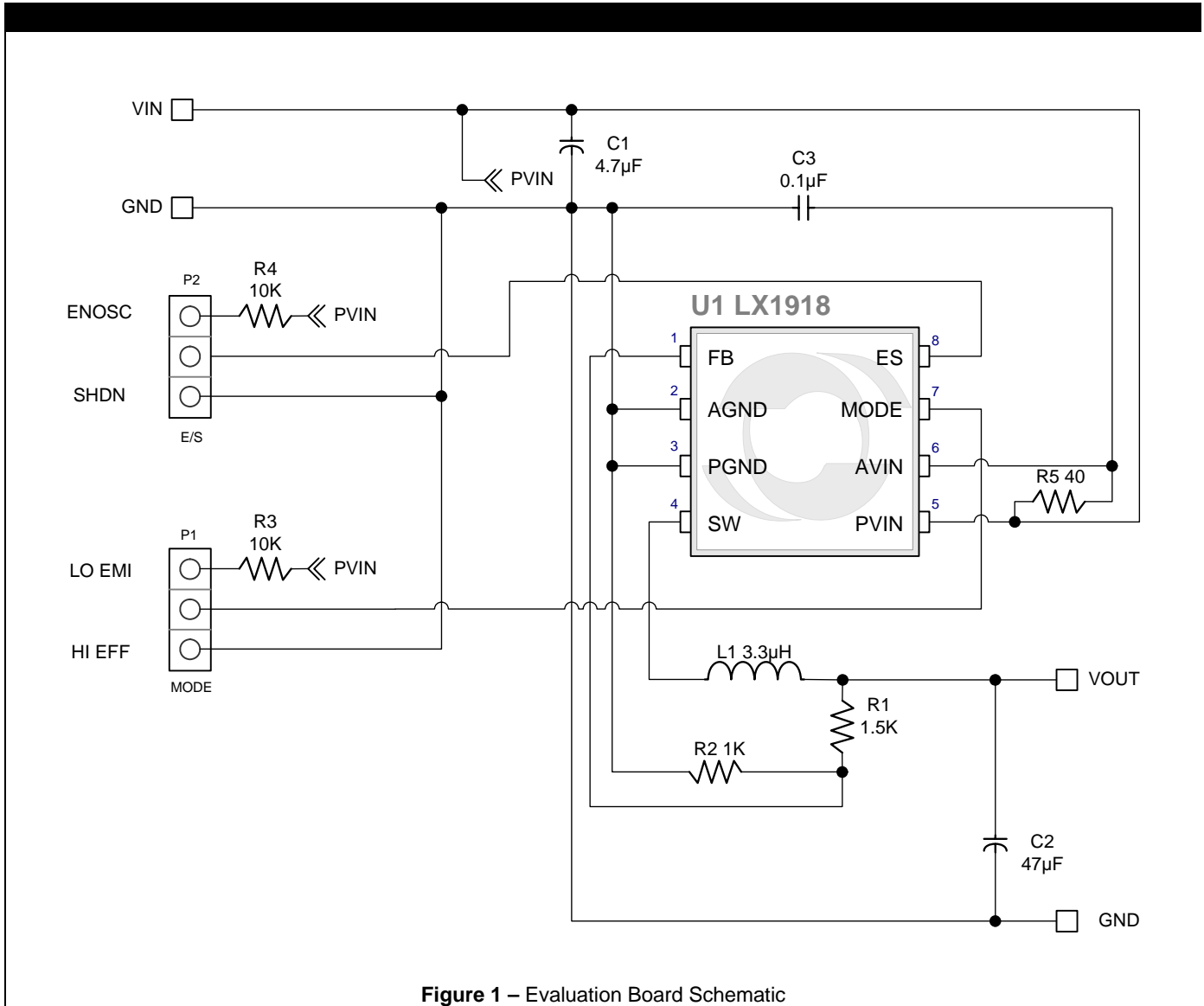

**Figure 1 – Evaluation Board Schematic**

### LX1918 EVALUATION HOOK UP

The following is a demonstration scenario to be used for evaluating the LX1918.

#### HOOK UP DIRECTION

1. Place Mode Jumper in HI EFF (high efficiency) position.

2. Place E/S Jumper in ENOSC position.
3. Apply 3.6V / 2A input between VIN and GND.
4. Connect to Load capable of handling the prescribed output (Board is set to 1.5V output by default).

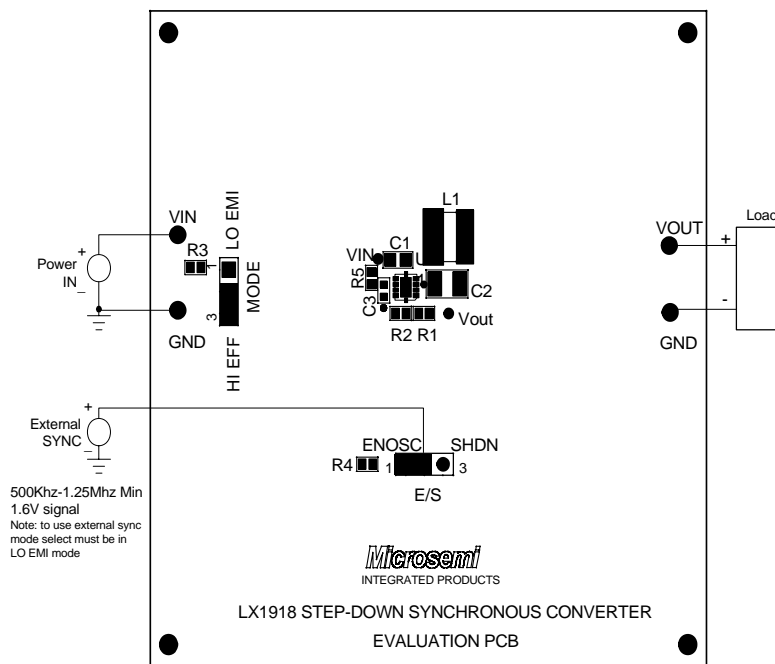

Figure 2 – Evaluation Board Hook Up

## CONNECTIONS

The LX1918 Evaluation board has 4 test lead attachment points for applying power and control signals and for monitoring voltages. There are also 2 – 3 pin connections to select external synchronization

and operating mode. The E/S selector also has shutdown capability

Function	Board Label	Connection
Input Power	VIN	Power Supply (2.70V $\pm$ 6.0V)
Power Ground	GND	Common Power Supply Ground
External Sync / Shutdown	E/S	Connect to GND to disable LX1918. A PWM > 500KHz logic PWM signal can also be applied <sup>1</sup> .
Output Voltage	VOUT	Test Point – Hook up load and monitor VOUT
Mode Select	Mode	High Efficiency = Pin 2 and 3. Low EMI = Pin 1 and 2.

1 – To use external synchronization feature the Mode Select must be in Lo EMI position.

## BILL OF MATERIALS

### MISCELLANEOUS COMPONENTS

Line Item	Part Description	Manufacturer & Part #	Case	Reference Designators	Qty
1	1.5A Synchronous Buck Converter	<b>MICROSEMI</b> LX1918CLD	LD	U1	1
2	Inductor 1.8A Shielded SMD 3.3 $\mu$ H	<b>COILCRAFT</b> MOS6020-332MX		L1	1
3	Header 3 Pin .100			P1, P2	2
4	Test Point – 0.045 diameter, Wire Loop	<b>KEYSTONE</b> 5004_Term			4
5	PCB SGE # 3534 X1				

### CAPACITORS

Line Item	Part Description	Part Description	Case	Reference Designators	Qty
1	Capacitor, 4.7 $\mu$ F, X5R, 10V, 20%	<b>TAIYO YUDEN</b> CELDK212BJ475MG	0805	C1	1
2	Capacitor, 47 $\mu$ F, X5R, 6.3V, 20%	<b>TAIYO YUDEN</b> JMK325BJ476MM	1210	C2	1
3	Capacitor, 0.1 $\mu$ F, X5R, 16V, 20%	<b>TAIYO YUDEN</b> CEEMK107BJ104MA	0603	C3	1

### RESISTORS

Line Item	Part Description	Part Description	Case	Reference Designators	Qty
1	Resistor, 1.5K, 1/16W, 5%	<b>PANASONIC</b> ERJ-3GSYJ152V	0603	R1	1
2	Resistor, 1K, 1/16W, 5%	<b>PANASONIC</b> ERJ-3GSYJ102V	0603	R2	1
3	Resistor, 10K, 1/16W, 5%	<b>PANASONIC</b> ERJ-3GSYJ103V	0603	R3, R4	2
4	Resistor, 40.2, 1/10W, 1%	<b>PANASONIC</b> ERJ-3EKF40R2	0603	R5	1