

# LX1792 Eval CLASS-D AUDIO AMPLIFIER EVALUATION BOARD USER GUIDE

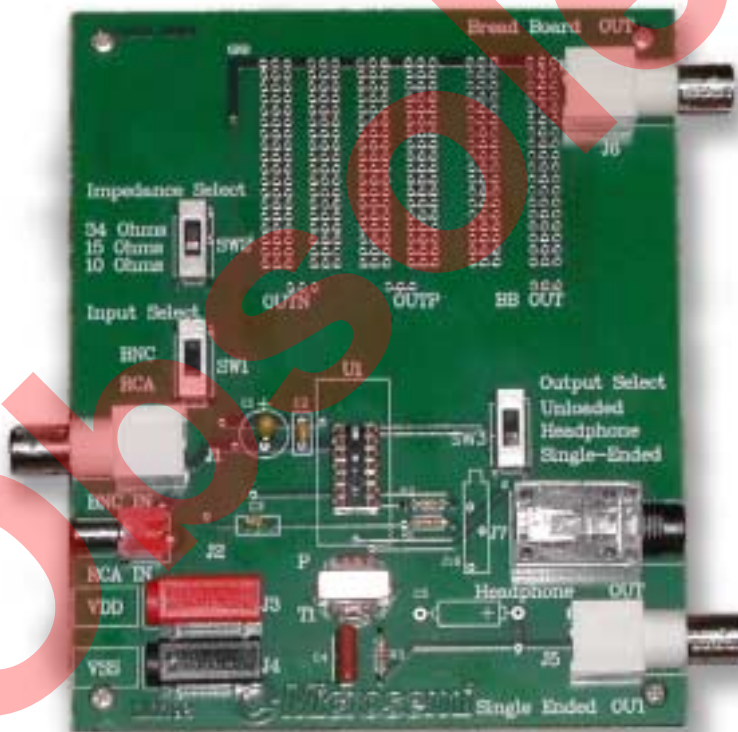

**Microsemi**  
INTEGRATED PRODUCTS  
Power Management

**TABLE OF CONTENTS**

**LX1792 Evaluation Board Features and Circuit Description** .....2  
    Input Select  
    Gain Set  
    Impedance Select  
    Output Select  
    Filter Stage  
    Breadboard  
**Quick Start Guide** .....4  
**Evaluation Board Schematic** .....6  
**Bill of Materials** .....7

Obsolete

## FEATURES AND CIRCUIT DESCRIPTION

- Fully Assembled Mono Evaluation Board with LX1792 Class-D Audio Amplifier
- Supports hearing aid bandwidth (100Hz - 10kHz)
- Gain set by 2 external resistors
- Three output impedance settings (10 $\Omega$ , 15 $\Omega$ , 34 $\Omega$ )
- Optimized to drive 200 $\Omega$  speaker load

The LX1792 Evaluation Board allows the user to quickly connect and evaluate the LX1792 Switching Class-D Mono IC. Banana jacks are provided for power supply connections. A RCA jack is supplied to input an audio signal, and a BNC connector is provided for a signal generator input. A slide switch is provided for easy selection between the two inputs. A ¼" audio jack is provided to connect headphones to the amplifier output. A single-ended, low-pass filtered output is also available through a BNC connector. This allows the user to connect the LX1792 output to either a spectrum analyzer or an oscilloscope. Breadboard space is also provided on the evaluation board to offer the user the opportunity to attach a different filter and/or load.

- Banana jacks for power supply connections
- RCA jack for audio input
- BNC jack for signal generator input
- ¼" Audio jack for headphone connection
- Single-ended output for measurement and analysis

The Class-D amplifier generates a Pulse Width Modulated output by controlling FETs that are connected in a H-Bridge configuration. The full bridge configuration is connected between the single supply voltage (VDD) and ground (VSS), with the output of the bridge driving a speaker or an equivalent load.

Because the FETs have an extremely low "on" resistance and an extremely high "off" resistance,

the majority (95% typical) of the power is delivered to the load, making it a highly efficient amplifier.

The only external component required by the LX1792 is an input AC coupling capacitor. The evaluation board contains two power supply filter capacitors, however, these are not mandatory for operation. The output of the LX1792 can be directly connected to a speaker.

### INPUT SELECT

The Evaluation Board provides two input connection options: a BNC connector and a RCA connector. The BNC connector should be used when inputting a signal from a function generator. The RCA connector should be used when inputting a signal from an audio source. A slide switch is provided to choose between these two input connectors.

### GAIN SET

Gain in the LX1792 amplifier can be set to a maximum total gain of 40dB. The preamp gain is set by the ratio of the external resistors (R2/R1). There is an additional 10dB gain in the H-bridge.

### IMPEDANCE SELECT

Three different output impedances are available with the LX1792. A slide switch allows users to choose between an output impedance of 10W, 15W, and 34W. The higher output impedance settings reduce current consumption of the LX1792.

### OUTPUT SELECT

The LX1792 evaluation board provides a slide switch that allows the user to choose between three different output options. When the switch is in the "Headphone" position, the differential output of the amplifier is applied directly to the headphone jack. If the "Single-Ended" option is chosen, the differential output is converted to a single ended output with a transformer, and then low-pass filtered. The "Unloaded" option removes the load from the amplifier output. This option can be used

if the user wants to connect the amplifier to a custom load on the breadboard.

#### FILTER STAGE

If the single-ended output is chosen, the amplifier output is connected to a transformer and then to a first order RC low-pass filter, with a cutoff frequency of 20kHz. This filter removes the 200kHz switching frequency from the signal.

#### BREADBOARD

The LX1792 gives the user the option of connecting the amplifier to a custom filter and load. The differential output of the LX1792 is wired directly to the breadboard. These signals are labeled "OUTP" and "OUTN" for the positive and negative outputs, respectively. The breadboard is also wired with ground for convenience. A BNC connector is provided to access the breadboard output.

Obsolete

## QUICK START GUIDE

The LX1792 Evaluation Board is a fully functional, Class-D Amplifier. To begin evaluation of the LX1792, just follow these simple steps.

- 1) Visually inspect the board to make sure that components were not damaged during shipping.
- 2) Power and Ground Connections The power and ground connections are made through banana jacks J3 and J4. Connect the positive terminal of the power supply or battery to J3, which is labeled "VDD". Connect the negative terminal of the supply or battery to J4, which is labeled "VSS". Make sure the correct connections are made before turning on power supply.
- 3) Input Connection  
To input a function generator signal, connect source to jack J1, labeled "BNC IN". To input an audio signal, connect source to jack J2, labeled "RCA IN".
- 4) Input Selection  
If using the BNC jack, set Input Select switch SW1 to the "BNC" position. If using the RCA jack, set SW1 to the "RCA" position.
- 5) Gain Set  
Choose the gain by selecting the external resistors ( $R1 > 25\text{Kohms}$ ).  $\text{Gain} = 10\text{dB} + 20\log(R2/R1)$
- 6) Output Impedance Selection  
For most Evaluation Board applications, the Impedance Select switch SW2 should be set to  $10\Omega$ . The other impedance settings reduce current consumption with the tradeoff of increasing switch output impedance.
- 7) Output Select  
The "Headphone" setting will directly connect the differential output of the amplifier to the headphone jack. The "Single-Ended" setting will connect the differential amplifier output to a transformer and convert it to a single-ended signal. The single-ended signal is then low-pass filtered with a cutoff frequency of 20kHz. The output of the low-pass filter is connected to BNC jack J5. The "Unloaded" setting will disconnect the amplifier from either load.
- 8) Output Connection  
To listen to the output of the amplifier, connect headphones to J7, labeled "Headphone OUT", and verify that the Output Select is set to "Headphone". Headphones with a minimum impedance of  $150\Omega$  should be used. To view the amplifier output on either a spectrum analyzer or an oscilloscope, connect to BNC connector J5, labeled "Single-Ended OUT", and verify SW4 is set to "Single-Ended".
- 9) Breadboard  
The differential output signal is directly available on the breadboard. The positive output is labeled "OUTP", and the negative output is labeled "OUTN". The power supply ground is also available on the breadboard, and is labeled "GND". BNC connector J6 is provided to access the breadboard output, which is labeled "BREADBOARD OUT". The positive output pin of J6 is wired to the breadboard, and is labeled "BB OUT". When using the breadboard, make sure the Output Select switch is set to "Unloaded".
- 10) Power Source  
If using a power supply, verify that it is set to 1.25V before connecting it to the Evaluation Board. A "C" (1.5V) battery can also be used.
- 11) Signal Generator Source  
Set the signal generator to the appropriate level for best results (see examples in table below).

Vin	Gain Setting
50mVrms	20dB
25mVrms	26dB
13mVrms	32dB
6mVrms	38dB

12) Audio Source

Verify that a low level audio source is being used, and set it to the minimum

level. Start or "play" audio source and adjust volume to desired level.

13) Listen

If the LX1792 is not operating properly, verify the preceding steps or contact Microsemi MicroPower for technical assistance (760) 431-5490.

Obsolete

EVAL SCHEMATIC

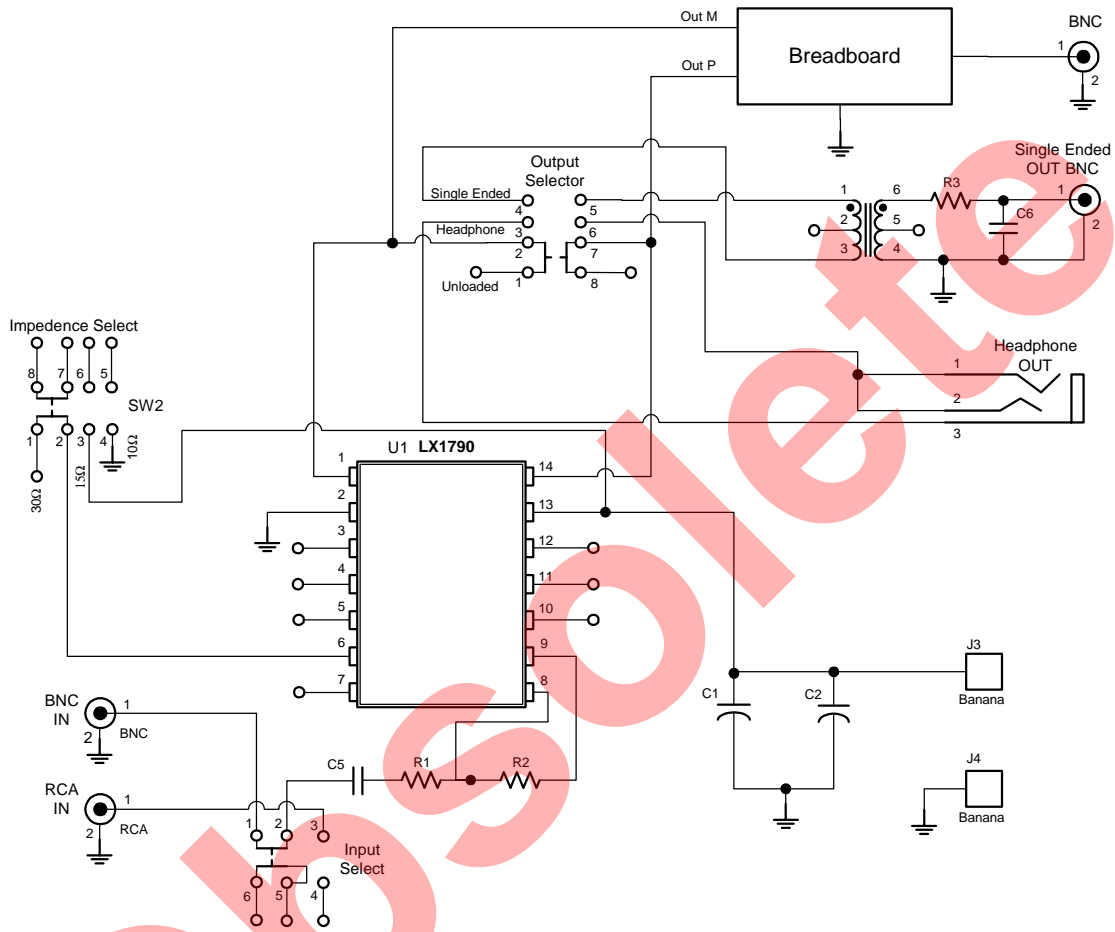

Figure 1 – Evaluation Board Schematic

## BILL OF MATERIALS

MISCELLANEOUS COMPONENTS					
Line Item	Part Description	Manufacturer & Part #	Case	Reference Designators	Qty
1	Class-D Amplifier IC	MICROSEMI LX1792CN *		U1	1
2	Banana Jack, Black	MOUSER 164-6218	TH	J4	1
3	Banana Jack, Red	MOUSER 164-6219	TH	J3	1
4	BNC Connector	MOUSER 523-31-5486-1010		J1, J5, J6	3
5	DPDT Slide Switch	MOUSER 612-EG2201		SW1	1
6	DP3T Slide Switch	MOUSER 612-EG2301		SW2, SW3, SW4	3
7	RCA Jack, Red	MOUSER 161-0096		J2	1
8	Transformer	MOUSER 42TL016		T1	1
9	14 Pin Cerdip Socket	MOUSER 571-26403574		U1	1
10	¼" Stereo Jack	MOUSER 161-0030		J7	1
CAPACITORS					
Line Item	Part Description	Part Description	Case	Reference Designators	Qty
1	Capacitor, 5mF, Electrolytic			C1	1
2	Capacitor, 1nF			C6	1
3	Capacitor, 100nF Ceramic			C2, C5	
RESISTORS					
Line Item	Part Description	Part Description	Case	Reference Designators	Qty
1	Resistor, 5.1kΩ			R3	1
2	Resistor, >25kW			R1	1
3	Resistor (Sets gain)			R2	1

\* Evaluation Board contains 1 LX1792CN part, order additional samples separately.