

LX1734 EVALUATION BOARD USER'S GUIDE

LX1734 1MHz Inverting DC-DC Converter

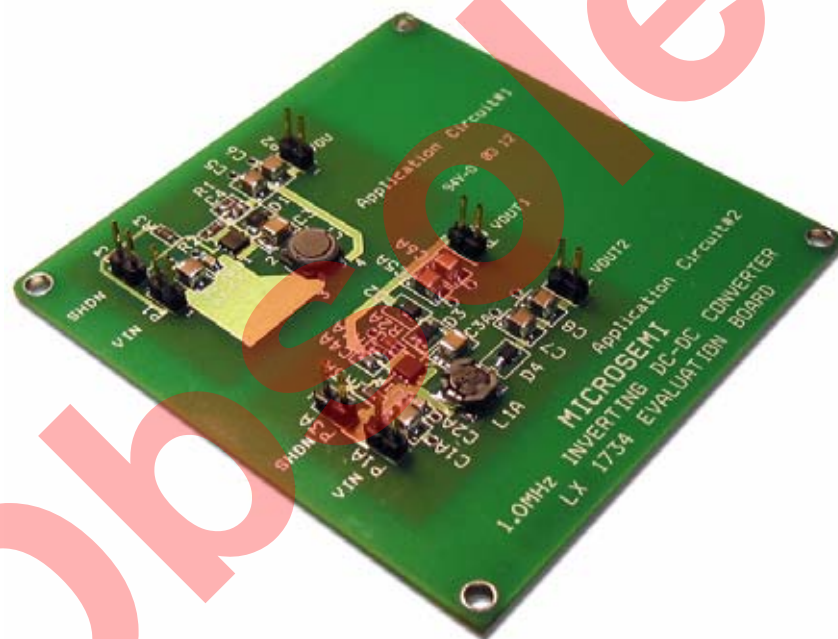

TABLE OF CONTENTS

Overview3
 LX1734 Overview
 Evaluation Board Operation

TABLES

Header Descriptions 3
 LX1734 Evaluation Board Component List 4

FIGURES

LX1734 Evaluation Board Silk Screen 4
 LX1734 Evaluation Board Schematic 5

Obsolete

OVERVIEW

The LX1734 is a fixed frequency (1MHz) current mode controller designed to develop a negative output voltage from a positive input voltage. The switching transistor and current sense resistor are integrated into the part. The PWM functions in a peak regulation mode using the amplified error signal to determine the peak switch current each cycle. Slope compensation is added to provide stable operation at high duty cycles. A current limit detector overrides the regulation loop and prevents the switch current from exceeding the over current threshold level.

The bandgap control circuit keeps Q1 biased on and produces a reference current (I_{REF}) that produces a voltage drop across the internal resistance that has a positive temperature coefficient.

When this resistor voltage drop is added to the negative temperature coefficient of the base-emitter voltage drop of Q1, the result is a temperature compensated reference voltage (V_{REF}) at the NFB pin. The summing node from the external feedback network is connected directly to NFB pin, which is relatively high impedance (typically 150k). The feedback loop minimizes the error current, (I_{ERROR}) which effectively regulates the voltage at the NFB pin. As with a conventional error amplifier, the error signal is proportional to the difference between the temperature compensated reference voltage

V_{REF}) and the summing node voltage. A slight correction factor is necessary to account for the added summing node voltage due to the reference current (I_{REF} , typically 4 μ ADC) flowing through the Thevenin equivalent summing node external resistance.

EVALUATION BOARD OPERATION

The LX1734 evaluation board contains two application circuits. Application circuit #1 is configured to provide a -5V output, and application circuit #2 is configured to provide both +5V and -5V outputs. Each application circuit has separate header connections associated with the input, output and shutdown pins for independent control of each circuit along with providing the user flexibility in applying a load to either circuit.

The header pin descriptions for application circuit #1 and application circuit #2 are summarized in Table 1 and Table 2 respectively. Please refer to these tables for evaluation board setup. The factory installed active and passive components list can be found in Table 3. Following the two tables you will find the PCB silkscreen Figure 1 and the circuit schematic in Figure 2. All necessary PCB traces and components are on the topside of the board.

Header Pin Description – Application Circuit #1	
VIN	Input Power (4.5V to 5.5V); P1-1 references the positive terminal, P1-2 references GND.
VOUT	Output Voltage (-5V); P2-1 references the output terminal; P2-2 references GND. User can either monitor the output voltage direct or apply an external load.
SHDN	Shutdown Pin; P3-1 references the positive terminal; P3-2 references GND. The LX1734 is active when SHDN > 2.0V. It is recommended to tie this pin to the VIN.

Table 1 – Header Explanation; Application Circuit #1

Header Pin Description – Application Circuit #2	
VIN	Input Power (4.5V to 5.5V); P1A-1 references the positive terminal, P1A-2 references GND.
VOUT1	Output Voltage (+5V); P2A-1 references the output terminal; P2A-2 references GND. User can either monitor the output voltage direct or apply an external load.
VOUT2	Output Voltage (-5V); P4-1 references the output terminal; P4-2 references GND. User can either monitor the output voltage direct or apply an external load.
SHDN	Shutdown Pin; P3A-1 references the positive terminal; P3A-2 references GND. The LX1734 is active when SHDN > 2.0V. It is recommended to tie this pin to the VIN.

Table 2 – Header Explanation; Application Circuit #2

LX1734 EVALUATION BOARD COMPONENT LIST

BILL OF MATERIALS

Part Description	Manufacturer & Part #		Reference Designators	Qty
IC, Converter	Microsemi	LX1734CLM	U1, U1A	2
Capacitor, X5R, 10uf, 6.3V, 10%, 1210	Murata	GRM32DR60J226MAD1L	C1, C1A, C5, C5A, C6, C6A, C7, C8	8
Capacitor, X7R, 100nf, 50V, 10%, 0805	Novacap	0805B104K500NT	C2, C2A	2
Capacitor, X7R, 1uf, 50V, 10%, 1210	Murata	GRM42-2X7R105K050AL	C3, C3A	2
Capacitor, X7R, 1.2nf, 16V, 10%, 0805	Novacap	0805B122K160NT	C4, C4A	2
Diode, Schottky, 1A, 20V, SMT	Microsemi	UPS5817	D1, D2, D3, D4	4
Inductor, 20uH, SMT	Sumida	CLS62-220NC	L1	1
Inductor, 47uH, 480mA, SMT	Toko	A920CY-470M	L1A	1
Connector, Vertical, 2-pin, .1 spacing	AMP	87220-2	P1, P1A, P2, P2A, P3, P3A, P4	7
Resistor, 29.4K, 1%, 1/10W, 0805	ASJ	CR21F2942T	R1, R1A	2
Resistor, 10.0K, 5%, 1/8W, 0805	ASJ	CR21J103T	R2, R2A, R3, R3A	4

Table 3 – LX1734 BOM

LX1734 EVALUATION BOARD SILKSCREEN

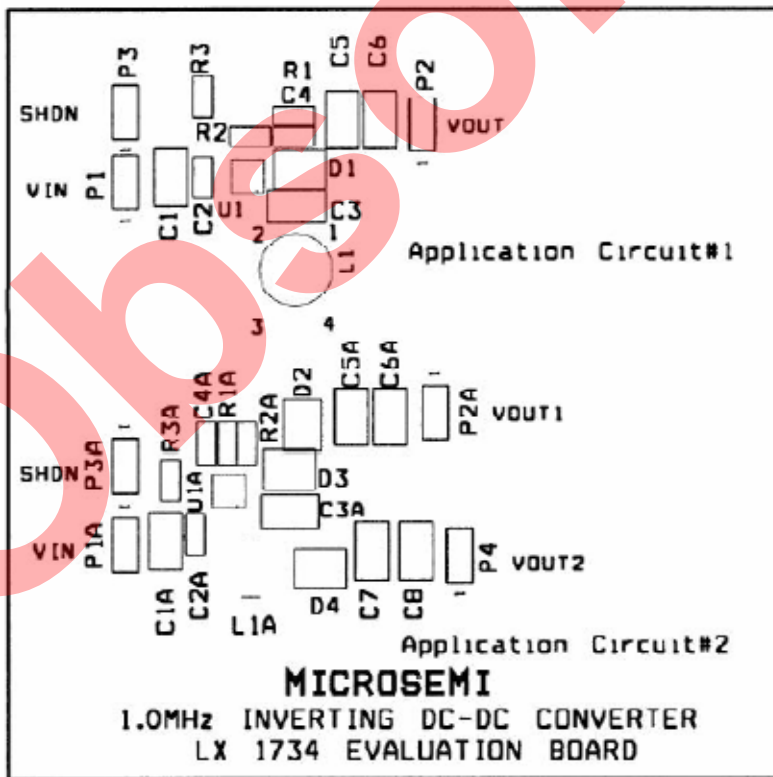
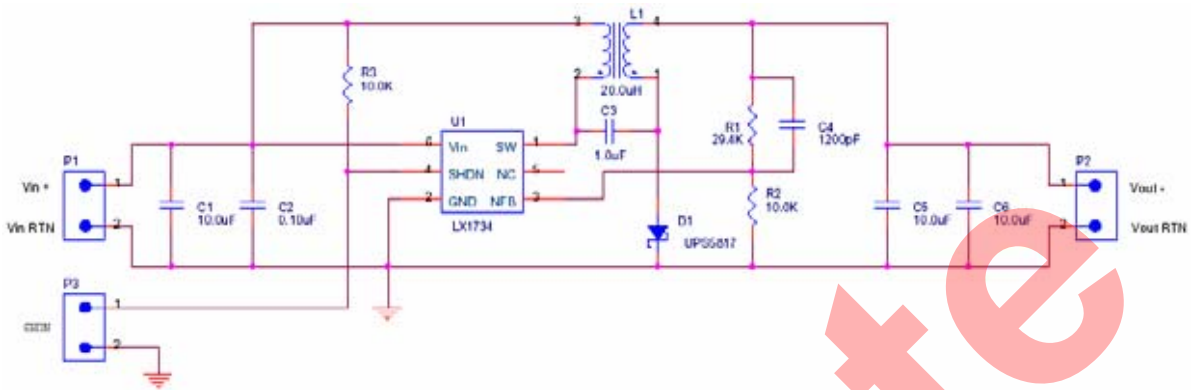
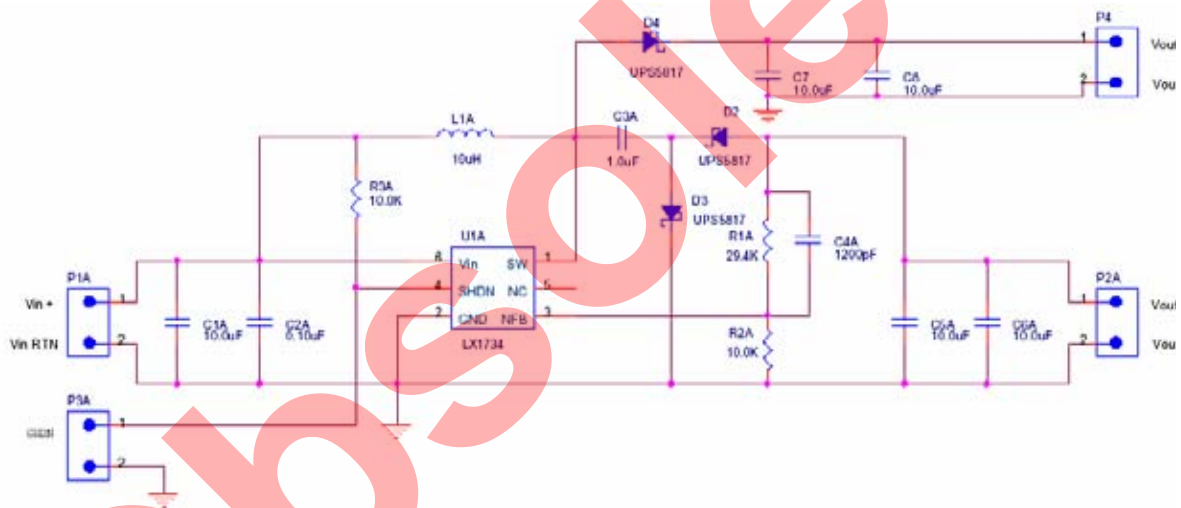

Figure 1 – Silkscreen Top RR

LX1734 EVALUATION BOARD SCHEMATIC



Application Circuit #1



Application Circuit #2

**Figure 2 – LX1734 Evaluation Board Schematic
-5V Output (Application Circuit #1) and +5V and -5V
Output (Application Circuit #2) Configurations**