

Class HC and Class KC Equivalents 1N6304-06 Ultrafast Rectifier Die

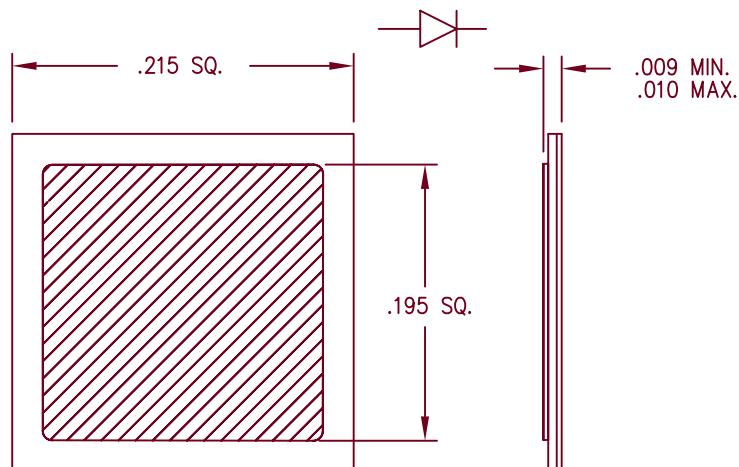

- Ultrafast Recovery Rectifier
- Glass passivated
- 70A Average, up to 150V
- Solderable silver both sides
- Available with Al top and/or gold back – contact factory
- Cells with moly discs available – contact factory

Part Number	V _{RRM}
1N6304HCE	50V
1N6304KCE	50V
1N6305HCE	100V
1N6305KCE	100V
1N6306HCE	150V
1N6306KCE	150V

Electrical Characteristics (Properly Packaged)

Average forward current	I _{F(AV)} 70 Amps	T _C = 100°C, Square wave, R _{θJC} = 0.8°C/W
Maximum surge current	I _{FSM} 800 Amps	8.3 ms, half sine, T _J = 55°C
Max peak forward voltage	V _{FM} .975 Volts	I _{FM} = 70A: T _J = 25°C*
Max peak forward voltage	V _{FM} 1.18 Volts	I _{FM} = 150A: T _J = 25°C*
Max peak forward voltage	V _{FM} .84 Volts	I _{FM} = 70A: T _J = 150°C*
Max peak reverse current	I _{RM} 30 mA	V _{RRM} , T _J = 150°C*
Max peak reverse current	I _{RM} 25 uA	V _{RRM} , T _J = 25°C*
Max reverse recovery time	t _{RR} 50 ns	I _F = .5A, I _R = 1A, (REC) = .25A, di/dt = 85A/μs
Max reverse recovery time	t _{RR} 60 ns	70A, 130A/μs, T _J = 25°C
Maximum junction capacitance	C _J 600 pF	V _R = 10V, f = 1Mhz, T _J = 25°C

*Pulse test: Pulse width 300 μsec, Duty cycle 2%

Group A Die Element Evaluation Electrical Tests

Subgroup	Method	Symbol	Min. Limit	Max. Limit	Unit
<u>Subgroup 2</u>	Forward voltage @ 70Apk	4011	V _{F1}	0.975	V _{dc(pk)}
	Forward voltage @ 150Apk	4011	V _{F2}	1.18	V _{dc(pk)}
	Forward voltage @ rated V _R	4016	I _{R1}	25	uA dc
<u>Subgroup 3</u>	Reverse current @ rated V _R , 150°C	4016	I _{R2}	30	mA dc
	Forward voltage @ 70Apk, 150°C	4011	V _{F3}	0.84	V(pk)
	Breakdown volt. @ 1 mA, -55°C	4021	V(BR)	400	mA(pk)
	1N6304		50		V _{dc}
	1N6305		100		V _{dc}
	1N6306		150		V _{dc}
<u>Subgroup 4</u>	Reverse recovery time @ 1/2A	4031	t _{rr1}	50	ns
	Reverse recovery time @ 70A	4031	t _{rr2}	60	ns
	Capacitance @ V _R = 10V	4001	C _J	600	pF
<u>Subgroup 7</u>	Forward recovery voltage	4026	V _{F(Dyn)}	2.2	V(pk)
	Forward recovery time	4026	t _{rr}	15	ns