

# LX1800 SMBus TO ANALOG INTERFACE

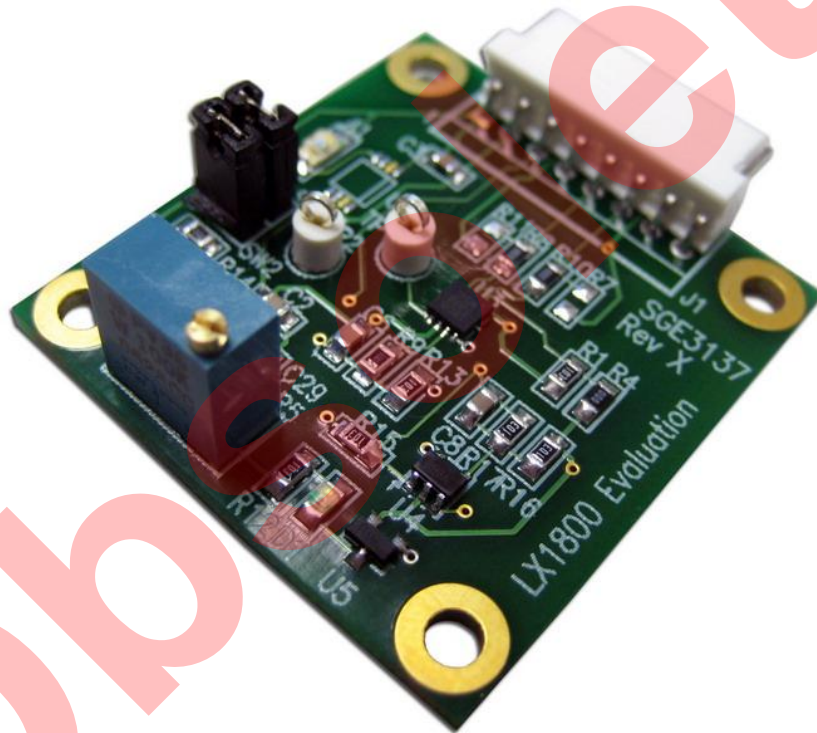

## INTRODUCING TO PRODUCT

The LX1800 Evaluation Board is available from Microsemi for evaluating the functionality and performance of the LX1800 SMBus to Analog Interface Integrated Circuit. The component sizes used on the evaluation board facilitate easy probing, however, in practice, smaller component sizes are recommended to minimize the circuit physical size.

## KEY FEATURES

- Wide Operating Range from a Single Supply of 2.7V to 5.5V
- 8 bit ADC & DAC on One Chip
- Fully Compliant to Standard SMBus
- Adaptable SMBus Speed from 10 kHz to 100 kHz
- Bus Controllable Sleep Mode Makes it Possible to Save More Power
- Optional External Reference Makes it More Flexible to Adapt to Analog Signals
- Two Addresses Selectable
- Easy to Program

## APPLICATIONS

- Processor Controlled Dimming
- VID Control Interface
- Digital Regulator Control
- Audio Volume Control
- Remote Control or Monitoring System

## PART SPECIFIC INFORMATION

Part Number	Product
LX1800ILD	SMBus to Analog Interface

Table 1 - PART INFORMATION

IC	EVALUATION BOARDS
LX1800ILD	LX1800 EVAL KIT

Table 2 - EVALUATION BOARD INFORMATION

**SCHEMATIC FOR LXE**

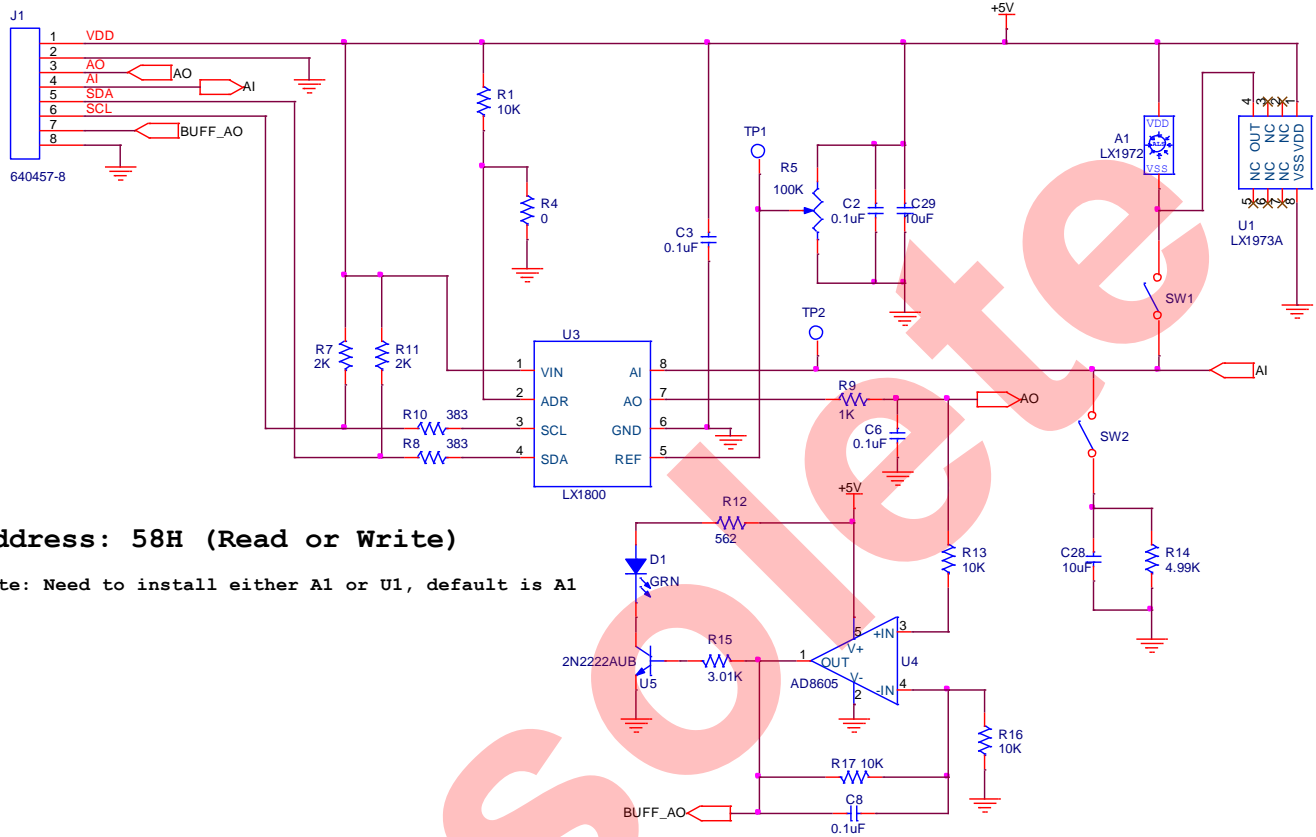

**Address: 58H (Read or Write)**

**Note: Need to install either A1 or U1, default is A1**

Figure 1 - LX1800 Evaluation Board Schematic

IC BLOCK DIAGRAM

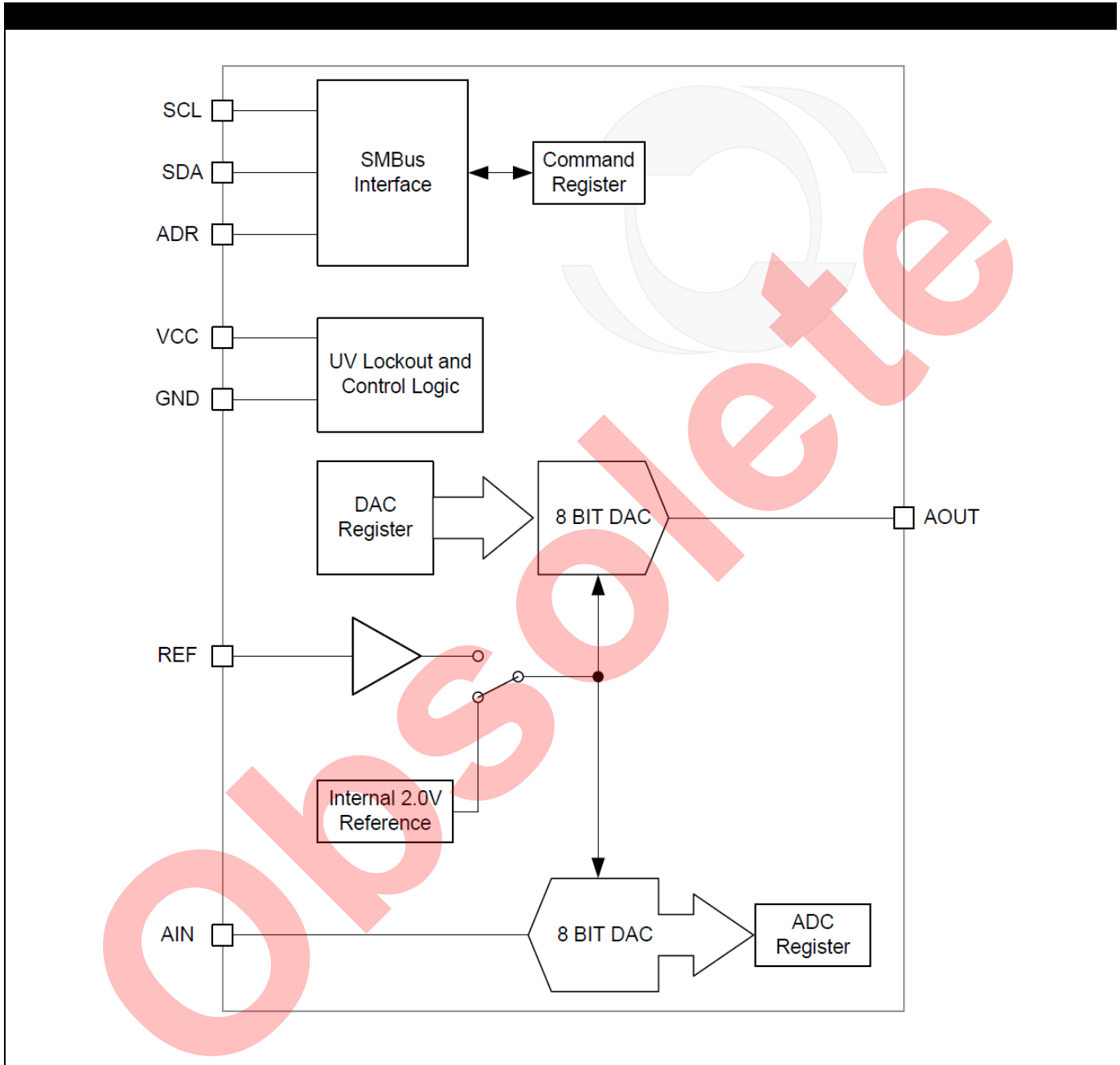

Figure 2 - Simplified Block Diagram

## LX1800 EVAL BOARD

**PCB Layout:** The LX1800 Eval board layout is shown in Figure 3. The LX1800 is sensitive to noise at the reference pin so this node should be a low impedance path to ground for high frequency noise. As a precaution, the REF node should be routed away from digital switching traces. The  $V_{DD}$  Pin should be decoupled to ground with a 0.1 $\mu$ F ceramic capacitor located in close proximity to the IC.

**Connections:** The LX1800 Evaluation Board has a 8-pin connector connecting to outside power and signals. The connection pin names and functions are listed below. Figure 4 is a suggested test connection diagram.

PIN #	PIN NAME	FUNCTION
1	$V_{DD}$	Power Supply
2	RTN	GND
3	AO	Analog Output
4	AI	Analog Input
5	SDA	SMBus Data
6	SCL	SMBus Clock
7	BUFF_AO	Buffered Analog Output
8	RTN	GND

**Table 3:** Connector Pin Assignment

**Jumpers:** The LX1800 Evaluation Board has two jumper blocks. The jumpers can be removed to de-select light sensor and its filter circuit. In this case, an outside analog signal could be used without being filtered.

**Test Steps:** The following is a demonstration scenario that can be used to evaluate the LX1800.

- 1) Make connections as shown in Figure 4. Apply 5V power source to the board. Measure Pin 1 and Pin 2 on connector J1 by using multimeter (Red lead to pin 1, black lead to pin 2) to verify +5V power is supplied to the board.

- 2) Verify the two jumpers are at ON position.
- 3) By using SMBus tester or other SMBus interface, send "58H, Write, 00, 0BEH" to LX1800. By doing this, LX1800 is set to a) Active mode; b) Use Internal reference; c) Start A/D conversion; d) Always On; e) Normal Polarity; f) ADC Loop Back; g) ADC Continuous; h) ADC uses internal clock. For reference, refer to SMBus Register Map on datasheet page.
- 4) Observe the Eval board, LED D1 brightness should change with the light input change to sensor A1. This can be easily verified by waving your hand on top of the sensor and observing the LED or comparing the two waveforms on the oscilloscope.
- 5) Send SMBus write command "58H, Write, 02", and then read command "58H, Read". The read back value should be the light sensor output voltage. Change the input light intensity to the sensor and repeat step 5; you should see the read back value changes.
- 6) Send "58H, Write, 00, 0BAH" to LX1800 to make it work at DAC input comes from Bus mode.
- 7) Send SMBus write command "58H, Write, 01, xx", observe the scope and LED, the waveform and LED brightness all should change.
- 8) Send SMBus Read command "58H, Write, 01", and then read command "58H, Read". The read back value should be the light sensor output voltage. Change the input light intensity to the sensor and repeat step 5, you should see the read back value changes.
- 9) If you wish not to use light sensor as analog input, you can remove two jumper caps. The buffered analog output has 2 times of the amplitude of AO output.

**LX1800 PRINTED CIRCUIT BOARD LAYOUT**

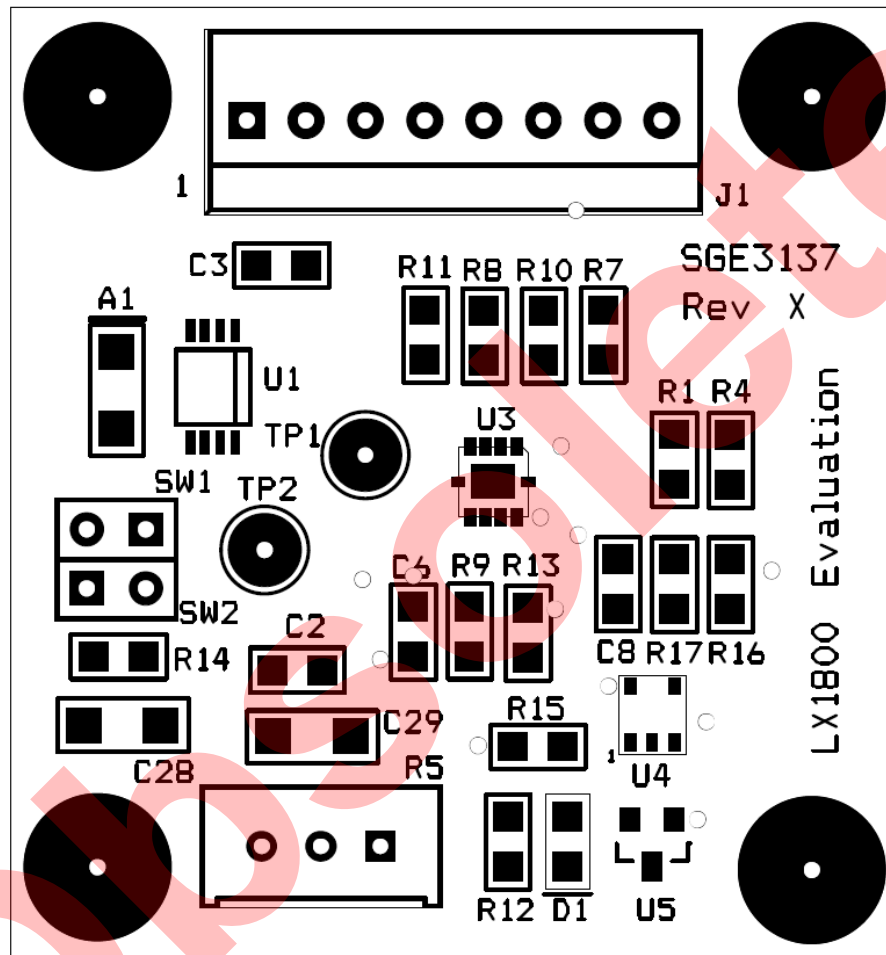

Figure 3 - LX1800 Evaluation Board Layout

**PCB LAYOUT RECOMMENDATIONS**

It is recommended that C1 and C2 be located within 1cm of the LX1800. The CMP capacitor should be located close to the IN and CMP pins. Also the high impedance summing node connecting to the TMP pin should be kept relatively short to prevent the coupling of noise into this node. It is important that the LX1800 have a good thermal path to ambient to dissipate heat. The simplest way to do this is to heat sink the LX1800 bottom pad directly to the ground plane by placing 4 or more Vias in the ground pad directly under the LX1800 footprint.

LX1800 TYPICAL TEST HOOKUP

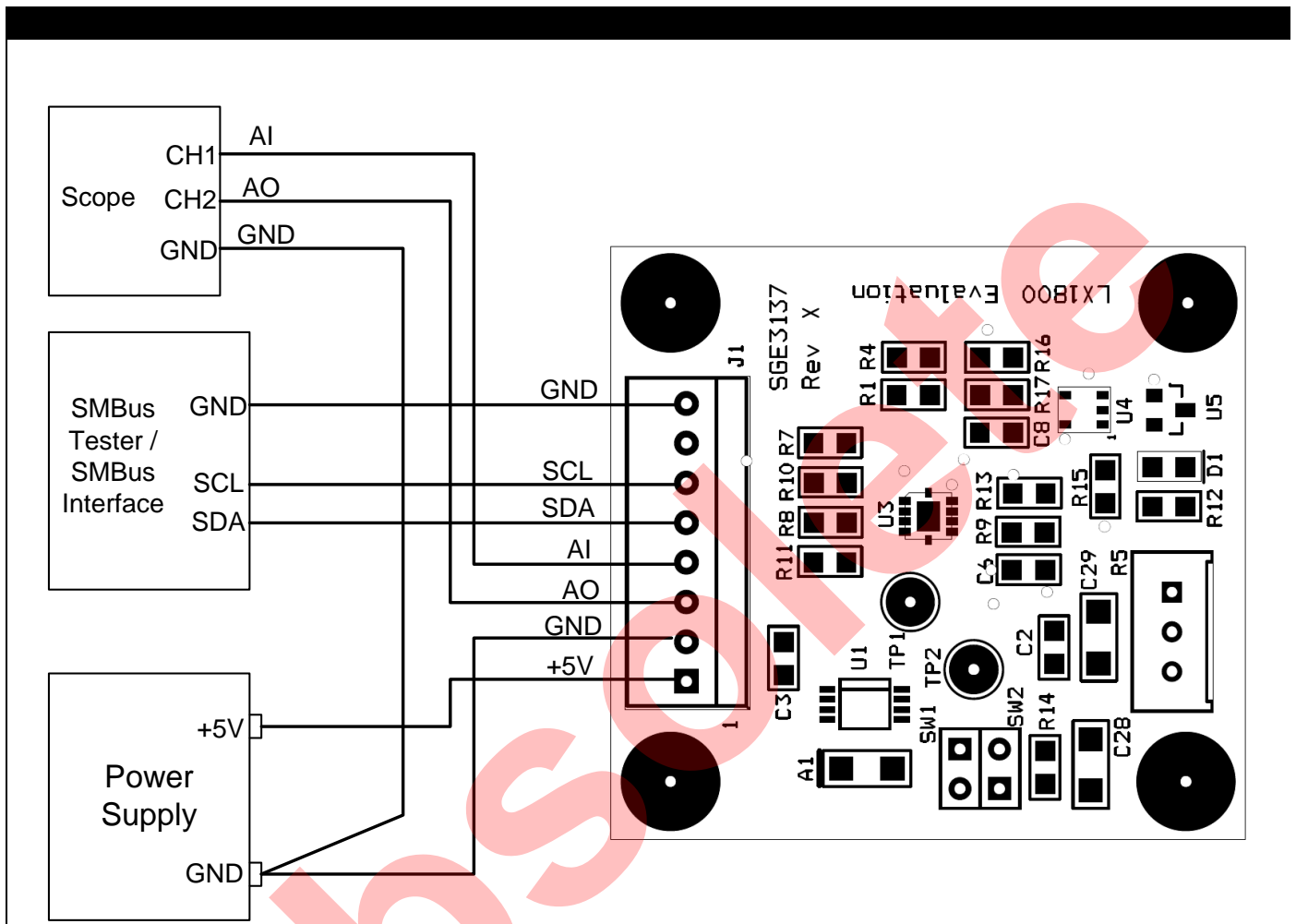

Figure 4 - LX1800 Typical Test Hookup

## LX1800 EVALUATION BOARD BILL OF MATERIALS

**MISCELLANEOUS COMPONENTS**

Line Item	Part Description	Manufacturer & Part #		Case	Reference Designators	Qty
1	Microsemi IC – Ambient Light Sensor	MICROSEMI	LX1972AIBC	1206	A1	1
2	Microsemi IC – SMBus to Analog Interface	MICROSEMI	LX1800ILD	3x3 MLP	U3	1
3	LED - Green	LITE ON	LTST-C170KGKT	0805	D1	1
4	CONN HEADER RTANG 8POS .100	AMP	640457-8	Through Hole	J1	1
5	Jumper	AMP	382811-6	Through Hole	SW1,2	2
6	Test Point	KEYSTONE	5007	Through Hole	TP1,2	2
7	Op-Amp	ANALOG DEVICES	AD8605ART	SOT-23-5	U4	1
8	NPN Transistor	DIODES	2N2222AUB	SOT-23	U5	1

**CAPACITORS**

Line Item	Part Description	Part Number		Case	Reference Designators	Qty
1	Capacitor, 0.1µF, 5V, ±20%	PANASONIC	ECJ-2VF1H104Z	0805	C2,3,6,8	4
2	Capacitor, 10µF, 16V, ±20%	PANASONIC	ECJ-MFF1C106Z	1206	C28,29	2

**RESISTORS**

Line Item	Part Description	Part Number		Case	Reference Designators	Qty
1	Resistor, 0K, 5%, 1/8W	PANASONIC	ERJ-6GEY0R00V	0805	R4	1
2	Resistor, 383, 1%, 1/8W	PANASONIC	ERJ-6ENF3830V	0805	R8,10	2
3	Resistor, 562, 1%, 1/8W	PANASONIC	ERJ-6ENF5620V	0805	R12	1
4	Resistor, 1K, 1%, 1/8W	PANASONIC	ERJ-6ENF1001V	0805	R9	1
5	Resistor, 2K, 1%, 1/8W	PANASONIC	ERJ-6ENF2001V	0805	R7,11	2
6	Resistor, 3.01K, 1%, 1/8W	PANASONIC	ERJ-6ENF3011V	0805	R15	1
7	Resistor, 4.99K, 1%, 1/8W	PANASONIC	ERJ-6ENF4991V	0805	R14	1
8	Resistor, 10K, 1%, 1/8W	PANASONIC	ERJ-6ENF1002V	0805	R1,13,16,17	4
9	Trim Pot, CERM 100K OHM 25TRN TOP	PANASONIC	ERJ-6ENF4991V	Through Hole	R5	1