



Ordering Information

ZL60620MxDy
 IB DDR Active Optical Cable

"x" denotes fiber jacket types
 "y" denotes available standard cable lengths
 (See end of document for details)

Features

- Single-construction cable solution with integrated optical-electrical conversion
- QSFP MSA cage-based solution
- Electrical hot-pluggable with latch-based insertion
- Digital Diagnostics Monitoring Interface
- Extended Reach: up to 100 m (meters)
- Flexibility: Bend Radius, 25 mm (millimeters)
- Low Weight: 175 g (grams) for a 10 m cable
- Performance: BER 1×10^{-15}
- Low power consumption, typ 1 W per port
- Compact: 20% edge saving compared to CX4; limited edge based protusion
- 0°C - 70°C Case Operating Temperature

Applications

General interconnection solution for QSFP based ports.

- InfiniBand based cluster configurations operating at single (2.5 G per channel) and dual (5 G per channel) data rates (SDR and DDR). Connections between:
 - Switch-Switch
 - Switch-HCA
 - HCA-HCA
- XAUI-10 GbE applications
- High Performance Computing and proprietary interconnections up to 5 Gbps per channel

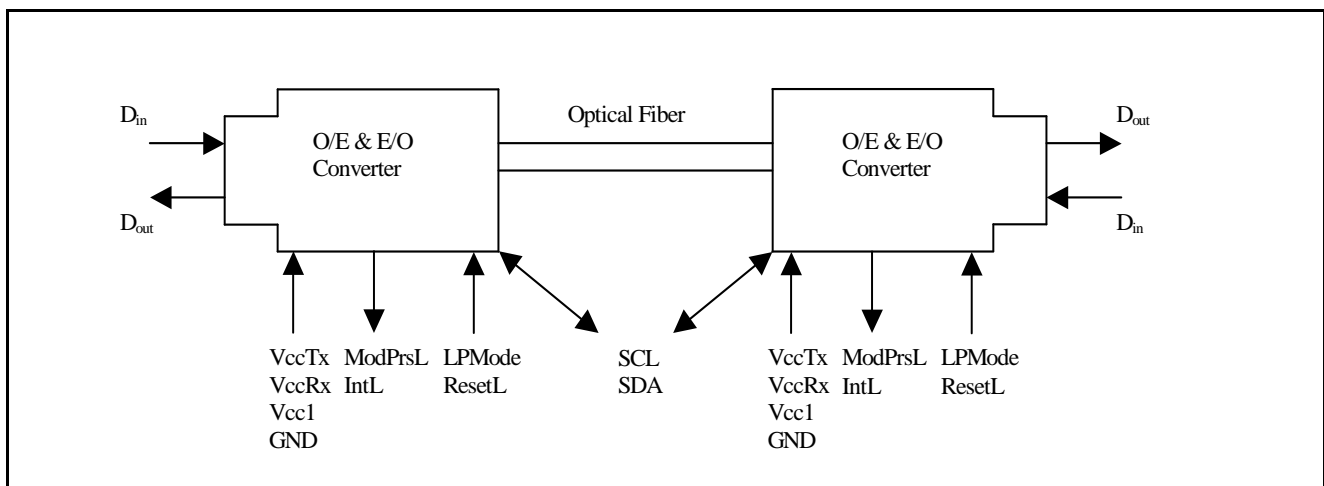

Figure 1 - QSFP Optical Cable Block Diagram

Description

The ZLynx QSFP cable product is part of the ZLynx family of fully integrated active optical cables, where the optoelectrical conversion is integrated into the end cable connectors. The ZLynx family is built on Zarlink's industry leading arrayed photonics, IC components and proprietary interconnect optical alignment technology.

The ZLynx QSFP, ZL60620, cable product is specifically designed for connection to QSFP MSA cage-based ports, an industry-standard 4-wide high speed electrical I/O connector solution. The cable is plug-and-play into these powered ports and provides the customer with all the advantages of an optical fiber solution without the worry of having to deal with the physical optical interconnection, the only connection being electrical.

ZL60620 has four differential electrical inputs and outputs, each capable of handling data rates up to 5 Gbps per channel, 20 Gbps duplex aggregate. The product is specifically designed to cover XAUI-10 GbE applications as well as Infiniband use at both Single (2.5 G) and Double (5 G) Data Rate, SDR and DDR, respectively.

The ZL60620 optical cable provides a high-performance, low-power interconnect solution that offers significant advantages to the end-user compared to copper-based cables.

These include:

- Extended Reach: reach of up to 60 m. Order of magnitude greater than copper reach of < 10 m
- Flexibility: bend radius of 25-mm. Improvement of 60% compared to 24 AWG copper cable.
- Weight and Size: 175 g (10 m) and 110 cm³ cable volume. An 80% weight and volume saving compare to 24 AWG copper cable.

In addition the ZL60620, being QSFP cage based offers 20% improvement in edge density compared to CX4 based solution.

Overall the improvements in reach, flexibility, weight and size provided by the ZL60620 optical cable combine to provide the system installers with improved layout flexibility, reduced installation times, improved air-flow management and reduced system weight-related layout constraints.

The ZL60620 product range also offers the customer a QSFP MSA based digital diagnostic monitoring interface allowing customer access to key parameters as well as providing alarm and warning flags. This improves the customers overall system management capability.

Reliability assurance is based on Telcordia GR-468-CORE. The product is compliant to the EU directive 2002/95/EC issued 27 January 2003 [RoHS].

ZL60620 is available in a number of standard cable lengths and jacket types (see Ordering Information).



**For more information about all Zarlink products
visit our Web Site at
www.zarlink.com**

Information relating to products and services furnished herein by Zarlink Semiconductor Inc. or its subsidiaries (collectively "Zarlink") is believed to be reliable. However, Zarlink assumes no liability for errors that may appear in this publication, or for liability otherwise arising from the application or use of any such information, product or service or for any infringement of patents or other intellectual property rights owned by third parties which may result from such application or use. Neither the supply of such information or purchase of product or service conveys any license, either express or implied, under patents or other intellectual property rights owned by Zarlink or licensed from third parties by Zarlink, whatsoever. Purchasers of products are also hereby notified that the use of product in certain ways or in combination with Zarlink, or non-Zarlink furnished goods or services may infringe patents or other intellectual property rights owned by Zarlink.

This publication is issued to provide information only and (unless agreed by Zarlink in writing) may not be used, applied or reproduced for any purpose nor form part of any order or contract nor to be regarded as a representation relating to the products or services concerned. The products, their specifications, services and other information appearing in this publication are subject to change by Zarlink without notice. No warranty or guarantee express or implied is made regarding the capability, performance or suitability of any product or service. Information concerning possible methods of use is provided as a guide only and does not constitute any guarantee that such methods of use will be satisfactory in a specific piece of equipment. It is the user's responsibility to fully determine the performance and suitability of any equipment using such information and to ensure that any publication or data used is up to date and has not been superseded. Manufacturing does not necessarily include testing of all functions or parameters. These products are not suitable for use in any medical products whose failure to perform may result in significant injury or death to the user. All products and materials are sold and services provided subject to Zarlink's conditions of sale which are available on request.

Purchase of Zarlink's I²C components conveys a license under the Philips I²C Patent rights to use these components in an I²C System, provided that the system conforms to the I²C Standard Specification as defined by Philips.

Zarlink, ZL, the Zarlink Semiconductor logo and the Legerity logo and combinations thereof, VoiceEdge, VoicePort, SLAC, ISLIC, ISLAC and VoicePath are trademarks of Zarlink Semiconductor Inc.

TECHNICAL DOCUMENTATION - NOT FOR RESALE
