



Alpha-Blender Core



Alpha-blenders play an important role in many video processing systems. They are primarily used when some portion of two video sources must be viewed at the same time. Where a simple MUX allows data from only one input source to be passed, an alpha-blender permits blending of the two sources for an eye-pleasing result.

FPGA resources can be quickly consumed by an alpha-blender due to the multiplication and addition associated with its function. Attodyne took measures to optimize the Alpha-Blender Core for minimum resource usage. One of these measures is limiting the alpha-blending levels to four—25, 50, 75, and 100%—, which will satisfy most applications.

The Alpha-Blender Core can be used in On-Screen Display (OSD) applications to give a transparent look to the overlay. Other examples include picture-in-picture, telemetry overlays, and touch-screen feedback systems.

Block Diagram

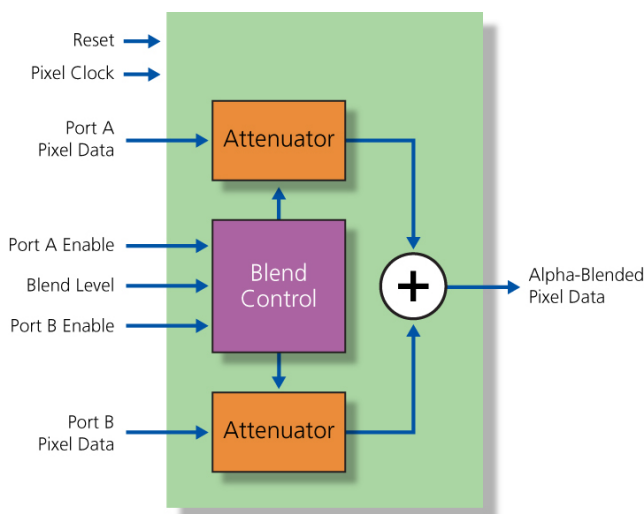

Two 24-bit RGB ports enter the Alpha-Blender Core and are controlled on a pixel-by-pixel basis by the combination of a 2-bit blending-level signal and their respective port-enable signals. This combination of controls facilitates a broad range of blending possibilities.

Depending on the control signals, the pixel data from each port is independently attenuated. Finally, the two attenuated vectors are summed together on a pixel-by-pixel basis to form the output video.

This product brief highlights Attodyne's resource-friendly version of this core. Please contact Attodyne if your application requires addition levels of blending.

Features

Blend Two Video Sources

- 4 levels of alpha-blending
- Full 24-bit RGB support

Enhances Product's Look and Feel

- Enables eye-pleasing overlays
- Increases perceived product value

Pixel-by-Pixel Blending

- Control inputs sampled for each pixel
- Permits creative use of the core

FPGA Resource-Friendly

- Optimized core
- Big results for few resources

Applications

- Medical imaging
- GPS navigation
- Video phones
- In-Car entertainment
- Notebooks
- Kiosks
- Casino machines
- ATMs
- POS advertising
- Avionics
- Military



Alpha-Blender Core



Device Utilization

Family	Device	Tiles	Clock Globals	I/O	PLLs	Block RAM	Utilization
IGLOO™	AGL125	303	1	78	0	0	9.6%
ProASIC®3	A3P125	303	1	78	0	0	9.6%
Fusion	AFS250	303	1	78	0	0	4.3%

Deliverables

- Complete IP Datasheet
- Actel Optimized Netlist
 - Netlist for target FPGA in EDIF, Verilog, or VHDL format
- RTL Source Cod
 - VHDL or Verilog source code
 - Functional verification testbench
 - Complete Libero® Integrated Design Environment (IDE) project

About Attodyne

As an Actel Solution Partner, Attodyne licenses IP cores relating to the processing, transmission, distribution and display of video data. Attodyne's design experience and capabilities span from ultra-low noise analog circuits to 4 Gbps fiber optic communications; however, video-related FPGA work is its primary focus. In addition to licensing IP Cores, Attodyne's products and services include reference designs, prototypes, design consultation, and product development.

Attodyne will help guide you early in your project to extract the maximum feature set and performance for your dollar spent on both hardware and firmware/software. Attodyne recommends Actel's FPGAs, as Actel's flash-based FPGA architecture is uniquely suited to video/LCD applications. Actel also provides superior support and creative flexibility to match its customer's needs. Due to a close working relationship with Actel, Attodyne has extensive knowledge of their FPGAs as well as their roadmap. This base of knowledge is extremely important when making long-term product and manufacturing decisions.