

## POWER SCHOTTKY RECTIFIERS™

### DESCRIPTION

This series of 75 Amp rated average forward current series of Schottky barrier power rectifiers in 20 through 50 volt selections is ideally suited for output rectifiers and catch diodes in low voltage power supplies. The Microsemi / Microchip high conductivity design, using a heavy copper top post and 4-point crimp, ensures cool thermal operation and low dynamic impedance with applicable heat sinking for peak repetitive forward currents up to 150 Amps at 50% duty cycle. This rugged DO-5 hermetically sealed design absorbs stress that can otherwise damage glass-to-metal seals during installation and operation. It is also available in a flexible top lead as described herein.

**Important:** For the latest information, visit our website <https://www.microsemi.com> / <https://www.microchip.com>.

### FEATURES

- Very Low Forward Voltage (0.6V at 60A, 125°C)
- Low Recovered Charge
- Rugged Package Design (DO-5)
- Low Reverse Current (<50mA at rated  $V_R$  at 125 °C)
- Hermetically sealed
- High Reliability Screening Option with HR2 Suffix (i.e. USD520HR2)
- Available with Flexible Top Lead with F suffix to part number

### APPLICATIONS / BENEFITS

- Output Schottky Rectifiers for Low Voltage Power Supplies
- Catch Diodes for Low Voltage Power Supplies
- High Efficiency for Low Voltage Supplies
- Robust Construction with Heavy Copper Top Post and Four-Point Crimp
- High Peak Operating Temperature
- Low Thermal Resistance (0.8 °C/W)
- High Surge Current (1000A)

### MAXIMUM RATINGS

Parameters/Test Conditions	Symbol	Value	Unit
DC Blocking Voltage	$V_R$	Same as $V_{RWM}$	V
Peak Repetitive Forward Current @ $T_c = 115\text{ °C}$ (Rated $V_R$ , Sq Wave, 20 kHz, 50% Duty Cycle)	$I_{FRM}$	150	A
Average Forward Current @ $T_c = 115\text{ °C}$	$I_{F(AV)}$	75	A
Non-Repetitive Peak Surge Current (8.3 ms)	$I_{FSM}$	1000	A
Peak Reverse Transient Current	$I_{RM}$	2	A
Storage Temperature Range	$T_{STG}$	-55 to +200	°C
Operating Junction Temperature	$T_{J(PK)}$	175	°C
Thermal Resistance, Junction to Case	$R_{\theta JC}$	0.8	°C/W

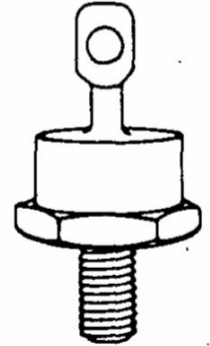

DO-5

#### MSC – Lawrence

6 Lake Street,  
Lawrence, MA 01841  
Tel: 1-800-446-1158 or  
(978) 620-2600  
Fax: (978) 689-0803

#### MSC – Ireland

Gort Road Business Park,  
Ennis, Co. Clare, Ireland  
Tel: +353 (0) 65 6840044  
Fax: +353 (0) 65 6822298

#### Website:

<https://www.microsemi.com>  
<https://www.microchip.com>

**MECHANICAL and PACKAGING**

- Industry Standard DO-5 (DO-203AB) Package with 11/16 inch Hex and ¼-28 Threaded Stud
- Hermetically Sealed metal and Glass Case Body
- Metal Surface Finish: Tin Plated
- Weight: 16 grams (approximate)
- Maximum Unlubricated Stud Torque: 30 inch pounds
- Angular Orientation of Terminal Undefined
- Marking: Part Number and Logo
- Flexible Top Lead Option: Add an "F" Suffix to Part Number
- See [Package Dimensions](#) on last page.

**ELECTRICAL CHARACTERISTICS (T<sub>CASE</sub> = 25°C)**

PART NUMBER		Working Peak Reverse Voltage V <sub>RWM</sub>	Non Repetitive Peak Reverse Voltage V <sub>RSM</sub> @ I <sub>RM</sub>	Maximum Forward Voltage V <sub>F</sub>			Maximum Reverse Current (pulsed)* I <sub>R</sub> @ V <sub>RWM</sub>		Maximum Capacitance @V <sub>R</sub> = 5.0 V
				@10A, 25°C	@60 A, 25°C	@60 A, 125°C	@T <sub>C</sub> = 25°C	@T <sub>C</sub> = 125°C	
USD520	USD520HR2	20 V	24 V	0.50 V	0.68 V	0.60 V or 0.63 V with flexible lead option	20 mA	50 mA	4000 pF
USD535	USD535HR2	35 V	42 V					50 mA	
USD545	USD545HR2	45 V	54 V	50 mA					
USD550	USD550HR2	50 V	60 V	75 mA					

Note: \*Duty Cycle = 1%

**OPTIONAL HIGH RELIABILITY (HR2) SCREENING**

SCREEN	MIL-STD-750 METHOD	CONDITIONS
1. High Temperature	1032	24 Hours @ T <sub>A</sub> = 150°C
2. Temperature Cycle	1051	F. 20 Cycles, -55 to +150°C. No dwell required @ 25°C, T≥10 min. @ extremes
3. Hermetic Seal a. Fine Leak b. Gross Leak	1071	H. Helium C. Liquid
4. Thermal Impedance	3101	
5. Interim Electrical Parameters	GO/NO GO	As Applicable
6. High Temperature Reverse Blocking	As Applicable	T=48 hrs, T <sub>C</sub> =125°C with applicable bias conditions
7. Final Electrical Parameters	GO/NO GO	As Applicable

OUTLINE AND CIRCUIT

Typical Forward Current vs Forward Voltage

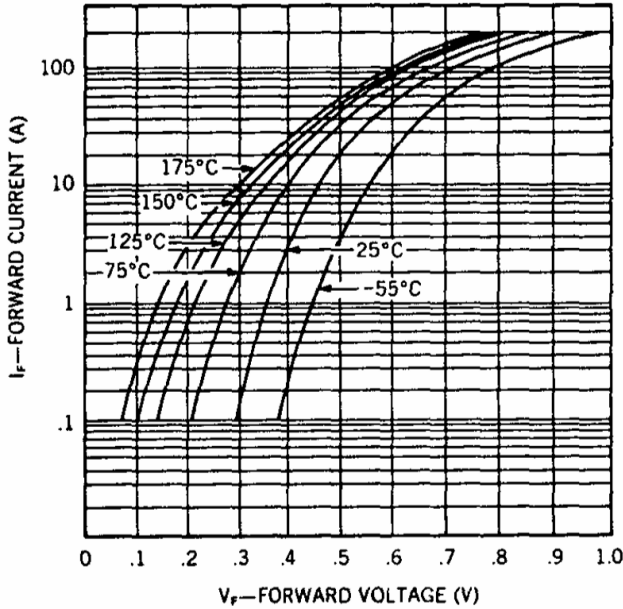

Typical Reverse Current vs Reverse Voltage

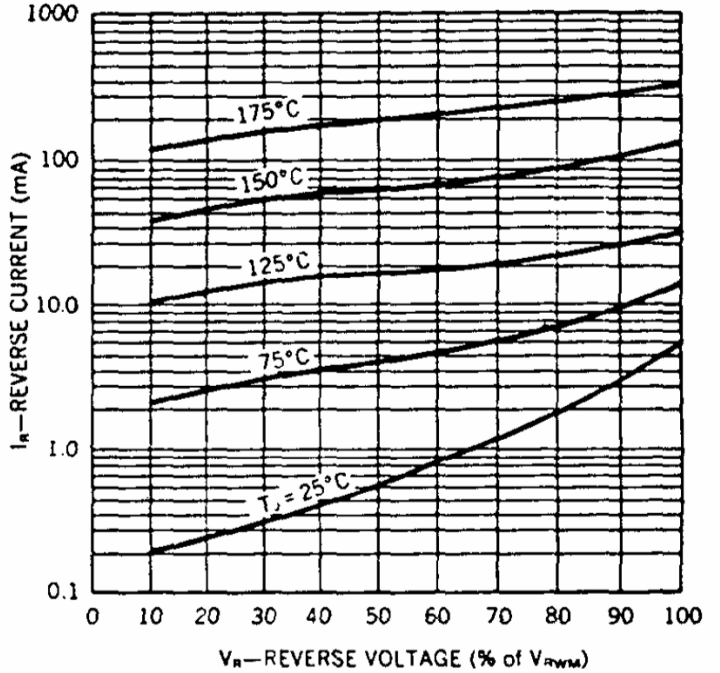

Maximum Current vs Case Temperature

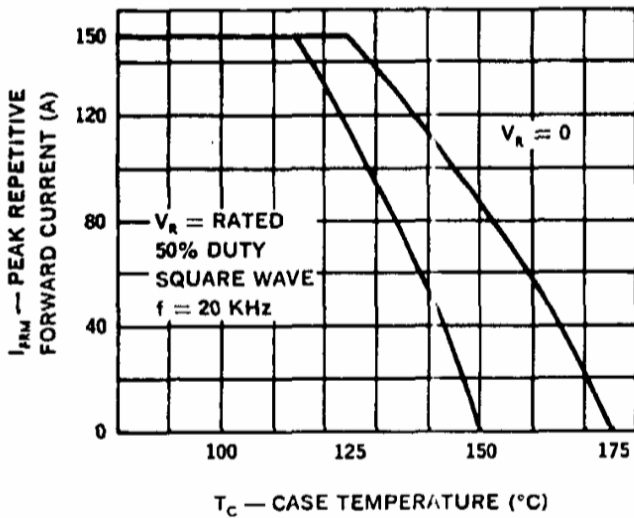

V<sub>R(MAX)</sub> Rating vs Case Temperature

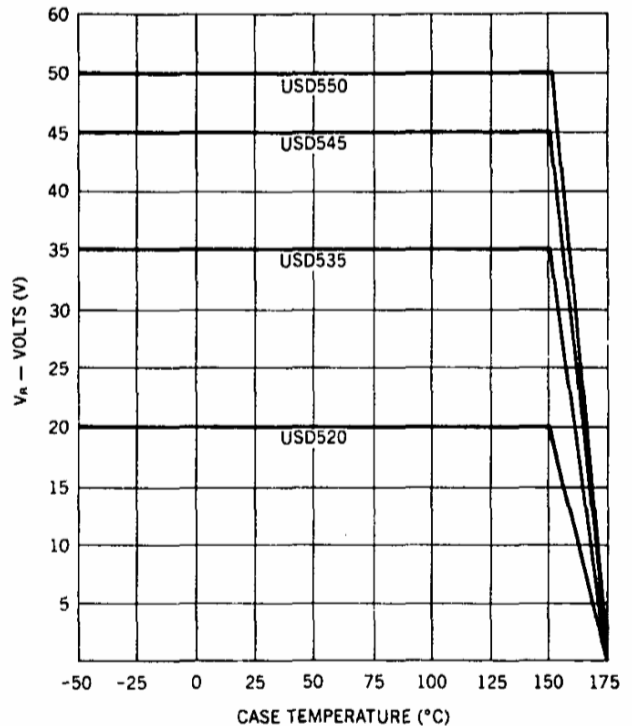

MECHANICAL SPECIFICATIONS

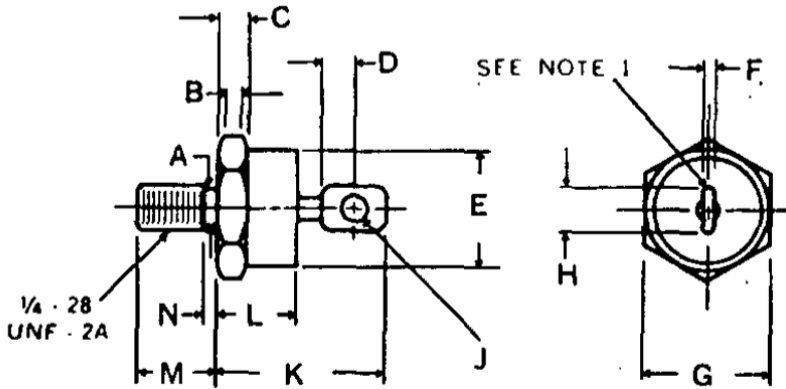

	INCHES	MILLIMETERS
A	.225 +/- .005	5.72 +/- 0.13
B	.060 MIN.	1.52 MIN.
C	.156 +/- .020	3.96 +/- 0.51
D	.156 MIN. FLAT	3.96 MIN. FLAT
E	.667 DIA. MAX.	16.94 DIA. MAX.
F	.090 MAX.	2.29 MAX.
G	.677 +/- .010	17.20 +/- 0.25
H	.375 MAX.	9.53 MAX.
J	.140 MIN. DIA.	3.56 MIN. DIA.
K	1.000 MAX.	25.40 MAX.
L	.450 MAX.	11.43 MAX.
M	.438 +/- .015	11.13 +/- 0.38
N	.078 MAX	1.98 MAX

Notes:

1. Cathode is stud
2. Maximum unlubricated stud torque: 30 inch pounds.
3. Angular Orientation of terminal is undefined.
4. Maximum tension (90°) anode terminal 15 pounds for 30 seconds.

FLEXIBLE TOP LEAD (OPTIONAL) Add an "F" suffix to Part Number.

Standard JEDEC DO-5 Package

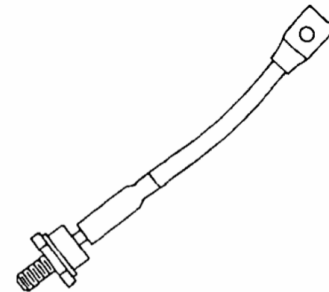
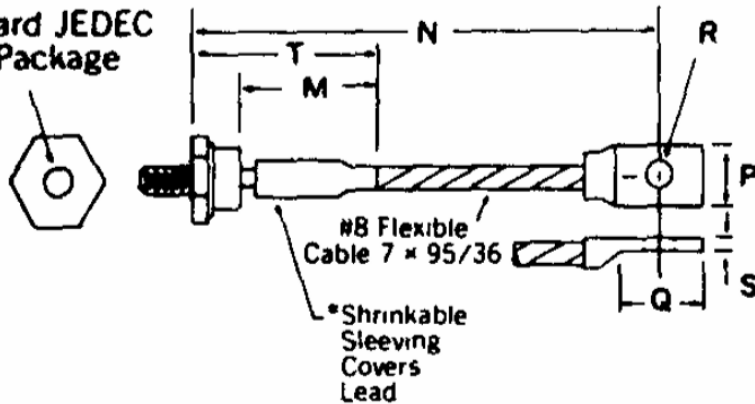

DO-5 with Flexible Lead

	INCHES	MILLIMETERS
M	.718 MAX.	18.24 MAX.
N	4.50 +/- .250	114.3 +/- 6.35
P	.525 MAX.	13.23 MAX.
Q	.675 +/- .035	17.15 +/- 0.89
R	.205 +/- .005	5.21 +/- 0.13
S	.075 +/- .010	1.91 +/- 0.25
T	1.125 MAX.	28.58 MAX.

\*To 125°C (Ambient)

Note: Consult Factory for Non-standard Lead Lengths