

## QUAD SOURCE MEMORY DRIVER

### DESCRIPTION

The SG55327/SG75327 is a monolithic quad source driver designed to meet the high current and fast switching speed requirements of magnetic memory systems. Each driver is independently controlled and capable of sinking up to 600mA.

Paired with the SG55326 Quad Sink Driver, the SG55327/SG75327 provides the current drive necessary for many sink/source applications.

The SG55327/SG75327 has also been used in many non-memory applications: for example, as the driver for a clock circuit, relay, lamp, or small motor, or any application where a 600mA source driver is needed.

The SG55327 is characterized for use over the full military operating ambient temperature range of -55°C to 125°C while the SG75327 is characterized from 0°C to 70°C.

These devices are available in 16-pin ceramic DIP, 16-pin plastic DIP and 16-pin flatpack.

### FEATURES

- Quad source memory drivers
- 600mA output current capability
- $V_{CC2}$  drive voltage variable to 24V
- Output capable of swinging between  $V_{CC2}$  and ground
- High-repetition-rate driver compatible with high-speed magnetic memories
- Inputs compatible with TTL decoders
- Minimum time skew between strobe and output-current rise
- Pulse-transformer coupling eliminated
- Drive-line lengths reduced

### HIGH RELIABILITY FEATURES - SG55327

- ◆ Available to MIL-STD-883
- ◆ Scheduled for MIL-M-38510 QPL listing
- ◆ LMI level "S" processing available

### BLOCK DIAGRAM

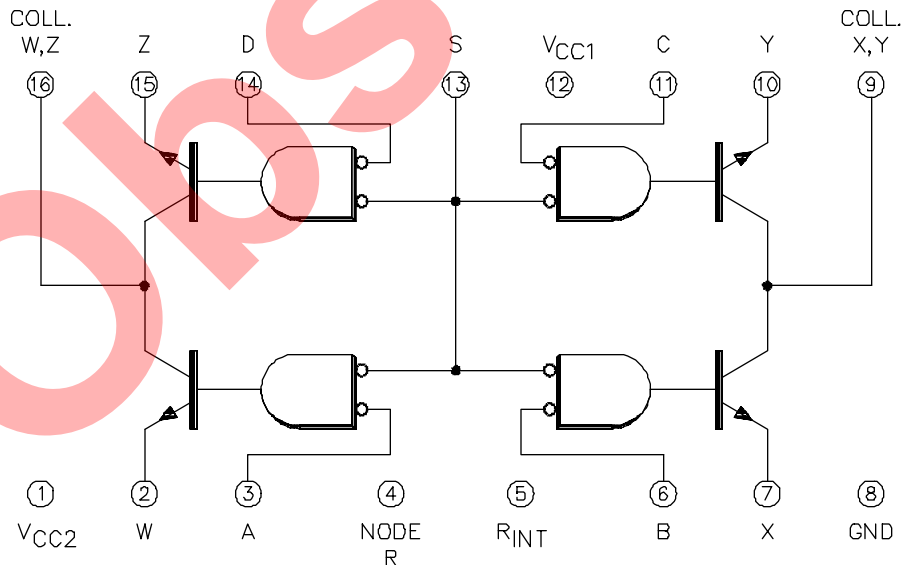

## ABSOLUTE MAXIMUM RATINGS (Note1)

Supply Voltage ( $V_{CC1}$ ) (Note 2) .....	7.0V
Supply Voltage ( $V_{CC2}$ ) .....	25V
Input Voltage (any address or strobe input) .....	5.5V
Output Collector Voltage .....	25V

Output Collector Current .....	750mA
Operating Junction Temperature ( $T_J$ )	
Hermetic (J, F-Packages) .....	150°C
Plastic (N-Package) .....	150°C
Storage Temperature Range .....	-65°C to 150°C
Lead Temperature (Soldering, 10 seconds) .....	300°C

Note 1. Values beyond which damage may occur.

Note 2. Voltage values are with respect to network ground terminal.

## THERMAL DATA

J Package:

Thermal Resistance-Junction to Case, $\theta_{JC}$ .....	30°C/W
Thermal Resistance-Junction to Ambient, $\theta_{JA}$ .....	80°C/W

N Package:

Thermal Resistance-Junction to Case, $\theta_{JC}$ .....	40°C/W
Thermal Resistance-Junction to Ambient, $\theta_{JA}$ .....	65°C/W

F Package:

Thermal Resistance-Junction to Case, $\theta_{JC}$ .....	70°C/W
Thermal Resistance-Junction to Ambient, $\theta_{JA}$ .....	115°C/W

Note A. Junction Temperature Calculation:  $T_J = T_A + (P_D \times \theta_{JA})$ .

Note B. The above numbers for  $\theta_{JC}$  are maximums for the limiting thermal resistance of the package in a standard mounting configuration. The  $\theta_{JA}$  numbers are meant to be guidelines for the thermal performance of the device/pc-board system. All of the above assume no ambient airflow.

## RECOMMENDED OPERATING CONDITIONS (Note 3)

Supply Voltage ( $V_{CC1}$ ) .....	4.5V to 5.5V
Supply Voltage ( $V_{CC2}$ ) .....	4.5V to 24V
Output Collector Voltage .....	24V

Output Collector Current .....	600mA
Operating Ambient Temperature Range:	
SG55327 .....	-55°C to 125°C
SG75327 .....	0°C to 70°C

Note 3. Range over which the device is functional.

## ELECTRICAL CHARACTERISTICS

(Unless otherwise specified, these specifications apply over the operating ambient temperatures for SG55327 with  $-55^\circ\text{C} \leq T_A \leq 125^\circ\text{C}$ , and SG75327 with  $0^\circ\text{C} \leq T_A \leq 70^\circ\text{C}$ . Low duty cycle pulse testing techniques are used which maintains junction and case temperatures equal to the ambient temperature.)

Parameter	Test Conditions	SG55327			SG75327			Units
		Min.	Typ.	Max.	Min.	Typ.	Max.	
<b>Static Section</b>								
High-Level Input Voltage ( $V_{IH}$ )		2			2			V
Low-Level Input Voltage ( $V_{IL}$ )				0.8			0.8	V
Input Clamp Voltage ( $V_{IK}$ )	$V_{CC1} = 4.5V, I_{IN} = -10mA, T_A = 25^\circ\text{C}$		-1.0	-1.7		-1.0	-1.7	V
Collectors Terminal Off-State Current ( $I_{OFF}$ )	$V_{CC1} = 4.5V, V_{COL} = 24V$			500			200	$\mu\text{A}$
	$V_{CC1} = 4.5V, V_{COL} = 24V, T_A = 25^\circ\text{C}$			150			200	$\mu\text{A}$
Saturation Voltage ( $V_{SAT}$ ) (Note 4)	$V_{CC1} = 4.5V, V_{OUT} = 0V, I_{SOURCE} = -600mA$			0.90			0.90	V
	$T_A = 25^\circ\text{C}$		0.43	0.70		0.43	0.75	V
Input Current ( $I_{IN}$ )	$V_{IN} = 5.5V$							
Address				1			1	mA
Strobe				4			4	mA
High-Level Input Current ( $I_{IH}$ )	$V_{IN} = 2.4V$							
Address				40			40	$\mu\text{A}$
Strobe				160			160	$\mu\text{A}$
Low-Level Input Current ( $I_{IL}$ )	$V_{IN} = 0.4V$							
Address			-1.0	-1.6		-1.0	-1.6	mA
Strobe			-4.0	-6.4		-4.0	-6.4	mA

**ELECTRICAL CHARACTERIZATICS** (continued)

Parameter	Test Conditions	SG55327			SG75327			Units
		Min.	Typ.	Max.	Min.	Typ.	Max.	
<b>Static Section</b> (continued)								
Supply Current ( $I_{CC(OFF)}$ )	All outputs off, all inputs at 5V, $T_A = 25^\circ\text{C}$						10	mA
From $V_{CC1}$		7.0	10		7.0	20		
From $V_{CC2}$		13	20		13			
Supply Current ( $I_{CC(ON)}$ )	One output on, $I_{SOURCE} = -50\text{mA}$ , $V_{COL} = 6\text{V}$ , $T_A = 25^\circ\text{C}$						12	mA
From $V_{CC1}$		8.0	12		8.0	55		
From $V_{CC2}$		36	55		36			

Parameter	To (output)	Test Conditions	SG55327/75327			Units
			Min.	Typ.	Max.	
<b>Dynamic Section</b> (Note 5)						
Propagation Delay, Low to High (TPLH)	Coll. W, Z or X, Y	$V_S = V_{CC2} = 15\text{V}$ , $R_L = 24\Omega$		35	55	ns
Propagation Delay, High to Low (TPHL)	Coll. W, Z or X, Y	$V_S = V_{CC2} = 15\text{V}$ , $R_L = 24\Omega$		30	55	ns
Transition Time, Low to High (TTLH)	W, X, Y, or Z	$V_{COL} = V_{CC2} = 20\text{V}$ , $R_L = 100\Omega$		30		ns
Transition Time, High to Low (TTHL)	W, X, Y, or Z	$V_{COL} = V_{CC2} = 20\text{V}$ , $R_L = 100\Omega$		10		ns
High-Level Output Voltage ( $V_{OH}$ ) (Note 6)	Coll. W, Z or X, Y	$V_S = V_{CC2} = 24\text{V}$ , $R_L = 47\Omega$ , $I_{SINK} \approx 500\text{mA}$	$V_S = 25$			mV

Note 4. Under these conditions, not more than one output is to be on any one time.

Note 5. Unless otherwise specified,  $V_{CC1} = 5\text{V}$ ,  $C_L = 25\text{pF}$ , and  $T_A = 25^\circ\text{C}$ .

Note 6. Guaranteed but not tested.

**CONNECTION DIAGRAMS & ORDERING INFORMATION** (See Notes Below)

Package	Part No.	Ambient Temperature Range	Connection Diagram
16-PIN CERAMIC DIP J - PACKAGE	SG55327J/883B SG55327J SG75327J	-55°C to 125°C -55°C to 125°C 0°C to 70°C	
16-PIN PLASTIC DIP N - PACKAGE	SG75327N	0°C to 70°C	
16-PIN CERAMIC FLAT PACK F - PACKAGE	SG55327F/883B SG55327F	-55°C to 125°C -55°C to 125°C	

Note 1. All packages are viewed from the top.

Note 2. Pin 8 is in electrical contact with the metal base.