



(SMBus) Ambient Light Sensor

DESCRIPTION

The LX1977 is a CMOS based Ambient Light Sensor (ALS) with an I<sup>2</sup>C compatible SMBus interface.

This device is ideal for controlling display back lighting systems of low cost consumer products such as TV, portable computers, handheld devices, or medical devices. The LX1977 is optimized for a linear, accurate, and very repeatable input and output transfer function. The device also features adjustable input range and gain.

The LX1977 has a spectral response that emulates the human eye. Specially designed circuitry produces peak spectral response at 555 nm, with IR response less than 10% above 810 nm.

Input dynamic range of this device is adjustable via SMBus command. It can be set to either 0 ~ 500 lux, 0 ~ 1000 lux, 0 ~ 2500 lux or 0 ~ 5000 lux.

ALS internal compensation ensures photodiode dark current are at very low levels, providing high output accuracy at low ambient light levels.

The LX1977 integrates a 12-bit Sigma-Delta A/D converter that converts the ALS photodiode output into a digital word. This value is read via the I<sup>2</sup>C compatible SMBus interface.

The LX1977 ALS is internally optimized to an accuracy of approximately 5% over temperature. The high accuracy and repeatability of this device eliminates the need of calibration during product production, which results in reduced assembly time and lower production cost.

The LX1977 is available in an 8-pin MSOP package, and is operational over the ambient temperature range -40°C to 85°C.

KEY FEATURES

- Human Eye Spectral Response
- Very Low IR Sensitivity
- 12-bit Resolution
- 5% Typical Accuracy
- Rejection to 50/60Hz Interference
- Programmable Integration Time
- Programmable Interrupt Pin
- I<sup>2</sup>C compatible SMBus Interface
- Easy Processor Interface
- No Optical Filter Needed

APPLICATIONS

- Backlight Control for Notebook
- Backlight Control for TV
- Handheld Devices
- Medical Devices

Note: I<sup>2</sup>C is a trade mark of Philips

PACKAGE ORDER INFO

THERMAL DATA

T <sub>A</sub> (°C)	<b>DU</b>	<b>3 x 5 Glass Top MSOP 8-pin</b>	<b>θ<sub>JA</sub> = 152 °C/W</b>
		RoHS Compliant / Pb-free	THERMAL RESISTANCE-JUNCTION TO AMBIENT
-40 to 85		<b>LX1977IDU</b>	Junction Temperature Calculation: T <sub>J</sub> = T <sub>A</sub> + (P <sub>D</sub> × θ <sub>JA</sub> ). The θ <sub>JA</sub> numbers are guidelines for the thermal performance of the device/pc-board system. All of the above assume no ambient airflow.
Note: Available in Tape & Reel. Append the letters "TR" to the part number. (i.e. LX1977IDU -TR)			

ABSOLUTE MAXIMUM RATINGS

V <sub>DD</sub> .....	-0.3 to 6V DC
Input Voltage to All Input Pins .....	-0.3V to V <sub>DD</sub> + 0.3V
SMBus Pin Voltage (SCL, SDA) .....	-0.3V to 5.5V
SMBus Pin Current (SCL, SDA) .....	< 10 mA
Operating Temperature Range .....	-40 to +85°C
Storage Temperature Range .....	-40 to 100°C
RoHS / Pb-free Peak Package Solder Reflow Temperature (40 seconds maximum exposure) .....	260° (+0, -5)

Notes: Exceeding these ratings could cause damage to the device. All voltages are with respect to Ground. Currents are positive into, negative out of specified terminal.

PACKAGE PIN OUT

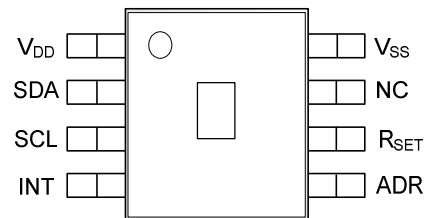

GLASS TOP MSOP 8 PIN  
(Top View)  
RoHS / Pb-free 100% Matte Tin

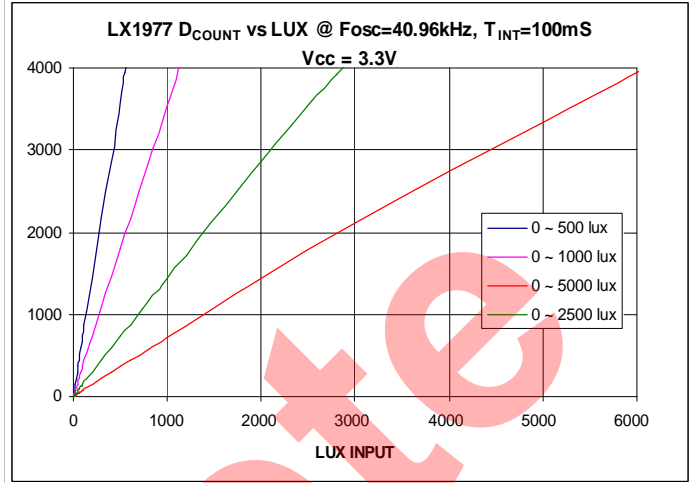
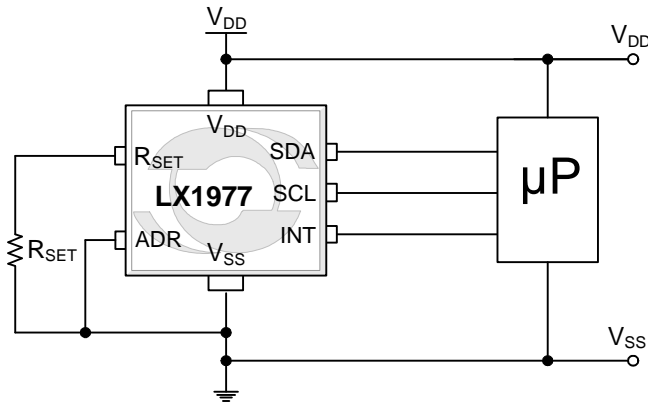
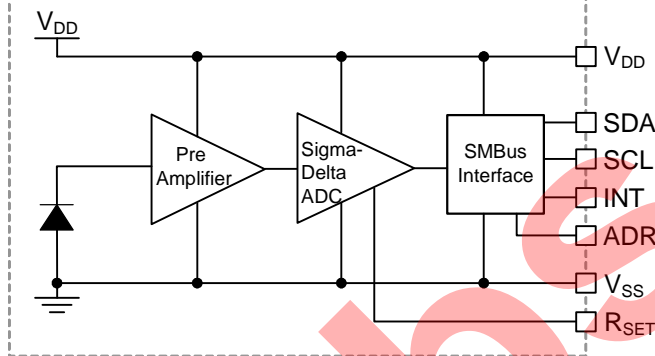
**PRODUCT HIGHLIGHT**

**SIMPLIFIED BLOCK DIAGRAM**

**Figure 1 – Simplified Block Diagram**
**PACKAGE PHOTO**

**Figure 2 – Product Photo**
**FUNCTIONAL PIN DESCRIPTION**

Name	Pin #	Dir	Description
V <sub>DD</sub>	1	PWR	Power Supply Voltage
SDA	2	I/O	SMBus Data – Connect To SMBus Data Line
SCL	3	I	SMBus Clock – Connect To SMBus Clock Line
INT	4	O	Interrupt Output Pin, Active Low, Open Drain
ADR	5	I	SMBus Address – The Address For This Device Is Determined By The State Of This Pin. ADR = GND sets address 20H, ADR = OPEN sets address 22H, ADR=V <sub>DD</sub> sets address 70H.
R <sub>SET</sub>	6	I	Gain Setting. For Gain Fine Adjustment. Typically, connect this pin to ground through a 1% 267k resistor.
NC	7		No Connection Pin
V <sub>SS</sub>	8	PWR	Ground Reference For Power And Signal Output



*Thank you for your interest in Microsemi<sup>®</sup> Analog Mixed Signal products.*

The full data sheet for this device contains proprietary information.

To obtain a copy, please contact your local Microsemi sales representative. The name of your local representative can be obtained at the following link  
<http://www.microsemi.com/contact/contactfind.asp>

or

Contact us directly by sending an email to: [IPGdatasheets@microsemi.com](mailto:IPGdatasheets@microsemi.com)

Be sure to specify the data sheet you are requesting and include your company name and contact information and or vcard.

We look forward to hearing from you.

Obsolète