

## N-CHANNEL MOSFET

### DEVICES

**APT5012WVR**  
**POWER MOS V<sup>®</sup>**  
**500V      40A      0.120Ω**

### LEVELS

#### ABSOLUTE MAXIMUM RATINGS ( $T_C = +25^\circ\text{C}$ unless otherwise noted)

Parameters / Test Conditions	Symbol	Value	Unit
Drain – Source Voltage	$V_{DS}$	500	Vdc
Gate – Source Voltage	$V_{GS}$	$\pm 30$	Vdc
Gate – Source Transient	$V_{GSM}$	$\pm 40$	Vdc
Continuous Drain Current $T_C = +25^\circ\text{C}$	$I_D$	40	Adc
Pulsed Drain Current $T_C = +25^\circ\text{C}$	$I_{DM}$	160	Adc
Total Power Dissipation Linear Derating Factor $T_C = +25^\circ\text{C}$	$P_D$	450 <sup>(1)</sup> 3.6	W W/°C
Drain to Source On State Resistance	$R_{ds(on)}$	0.120 <sup>(2)</sup>	$\Omega$
Operating & Storage Junction Temperature Range	$T_{op}, T_{stg}$	-55 to +150	°C
Lead temperature: 0.063" from Case for 10 Se.	$T_L$	300	°C
Avalanche Current <sup>(3)</sup> (Repetitive/ Non-repetitive)	$I_{AR}$	40 <sup>(1)</sup>	Adc
	$E_{AR}$	50 <sup>(1)</sup>	mJ
	$E_{AS}$	2500 <sup>(4)</sup>	mJ

**Note:** (1) Repetitive Rating: Pulse width limited by maximum junction temperature.

(2) Pulse Test: Pulse width < 380 $\mu\text{s}$ , Duty Cycle < 2%.

(3) MIL-STD-750 Method 3471.

(4) Starting  $T_j = +25^\circ\text{C}$ ,  $L = 3.13\text{mH}$ ,  $R_G = 25\Omega$ , Peak  $I_L = 40\text{A}$ .

#### ELECTRICAL CHARACTERISTICS ( $T_A = +25^\circ\text{C}$ , unless otherwise noted)

Parameters / Test Conditions	Symbol	Min.	Max.	Unit
Drain-Source Breakdown Voltage $V_{GS} = 0\text{V}$ , $I_D = 250\mu\text{Adc}$	$V_{(BR)DSS}$	500		Vdc
Gate-Source Voltage (Threshold) $V_{DS} = V_{GS} = \pm 30$ , $I_D = 2.5\text{mA}$	$V_{GS(th)}$	2.0	4.0	Vdc
Gate Current $V_{GS} = \pm 30\text{V}$ , $V_{DS} = 0\text{V}$	$I_{GSS}$		$\pm 100$	nAdc
Drain Current $V_{GS} = 0\text{V}$ , $V_{DS} = 500\text{V}$ $V_{GS} = 0\text{V}$ , $V_{DS} = 400\text{V}$ , $T_C = +125^\circ\text{C}$	$I_{DSS1}$ $I_{DSS2}$		25 0.25	$\mu\text{Adc}$
Diode Forward Voltage $V_{GS} = 0\text{V}$ , $I_D = 31.5\text{A}$ pulsed	$V_{SD}$		1.3	Vdc

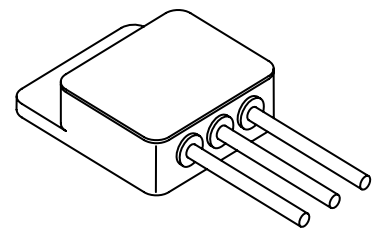

**TO-267**

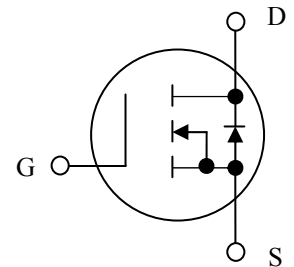

## DYNAMIC CHARACTERISTICS

Parameters / Test Conditions	Symbol	TYP	Max.	Unit
Capacitance:				
Input capacitance	$C_{iss}$	7400	8900	pF
Output Capacitance	$C_{oss}$	1000	1400	
Reverse Transfer Capacitance	$C_{rss}$	380	570	
Gate Charge:				
On-State Gate Charge <sup>(3)</sup>	$Q_{g(on)}$	312	470	nC
Gate to Source Charge	$Q_{gs}$	50	75	
Gate to Drain ("Miller") Charge	$Q_{gd}$	127	190	

## SWITCHING CHARACTERISTICS

Parameters / Test Conditions	Symbol	TYP	Max.	Unit
Switching time tests:				
Turn-on delay time	$t_{d(on)}$	14	30	ns
Rinse time	$t_r$	165	80	
Turn-off delay time	$t_{d(off)}$	54	80	
Fall time	$t_f$	5	10	
Continuous Source Current (Body Diode)	$I_S$		40	A
Pulsed Source Current <sup>(1)</sup> (Body Diode)	$I_{SM}$		160	A
Diode Forward Voltage <sup>(2)</sup> $V_{GS} = 0V, I_S = -40A$	$V_{SD}$		1.3	V
Reverse Recovery Time	$t_{rr}$	620		ns
Reverse Recovery Charge	$Q_{rr}$	14.7		uC

## THERMAL CHARACTERISTICS

Parameters / Test Conditions	Symbol	TYP	Max.	Unit
Junction to Case	$R_{\theta JC}$		0.28	°C/W
Junction to Ambient	$R_{\theta JA}$		40	°C/W

- (1) Repetitive Rating: Pulse width limited by maximum junction temperature.
- (2) Pulse Test: Pulse width < 380µs, Duty Cycle < 2%
- (3) See MIL-STD-750 method 3471
- (4) Starting  $T_j = +25^\circ C$ ,  $L = 3.13mH$ ,  $R_G = 25\Omega$ , Peak  $I_L = 40A$

## GRAPHS

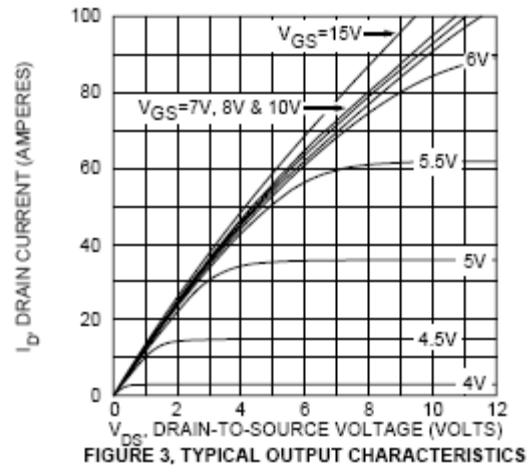
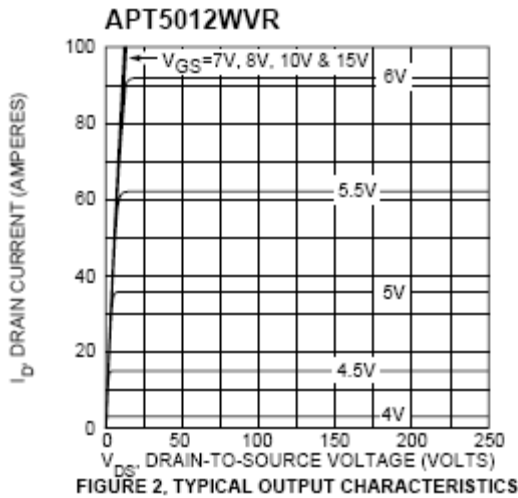
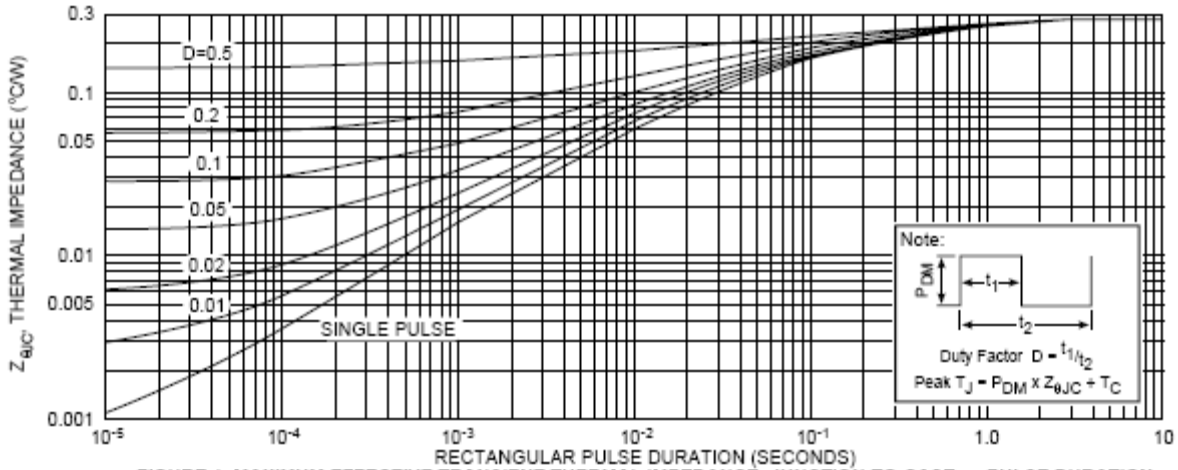

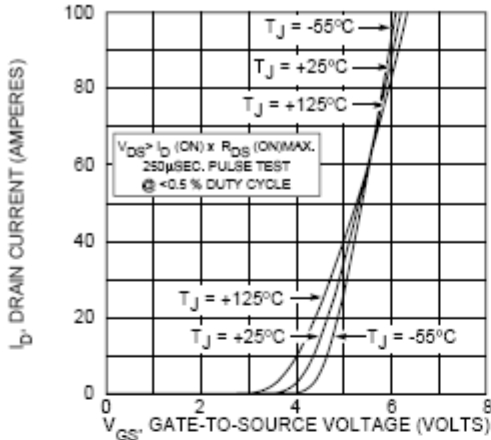

FIGURE 4. TYPICAL TRANSFER CHARACTERISTICS

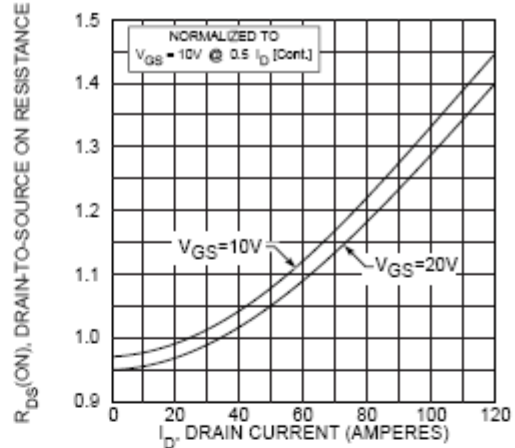

FIGURE 5.  $R_{DS(ON)}$  vs DRAIN CURRENT

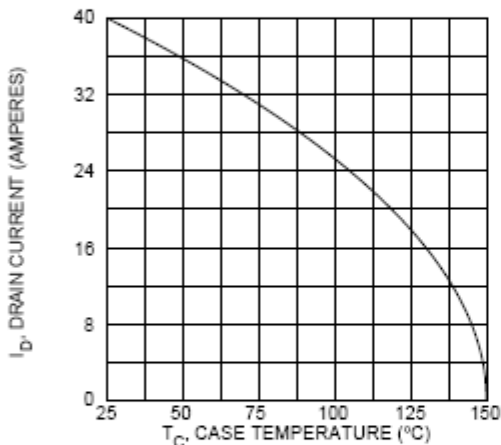

FIGURE 6. MAXIMUM DRAIN CURRENT vs CASE TEMPERATURE

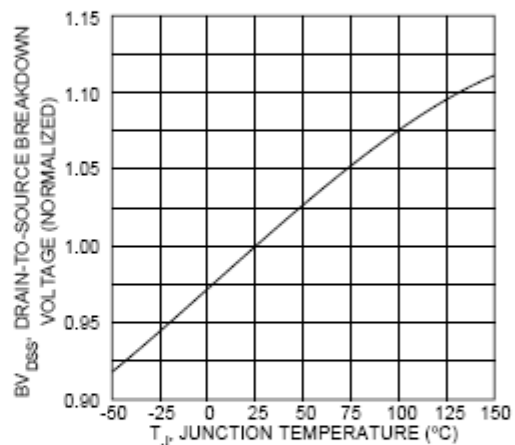

FIGURE 7. BREAKDOWN VOLTAGE vs TEMPERATURE

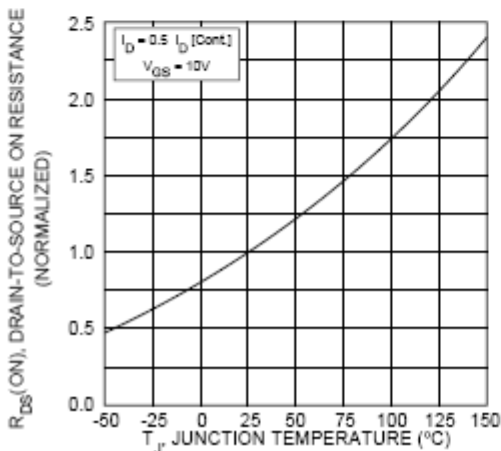

FIGURE 8. ON-RESISTANCE vs. TEMPERATURE

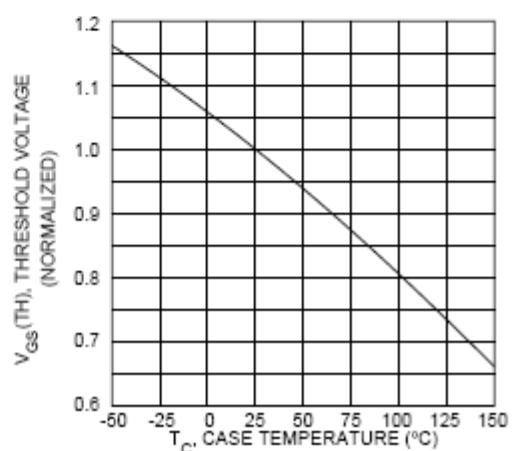

FIGURE 9. THRESHOLD VOLTAGE vs TEMPERATURE

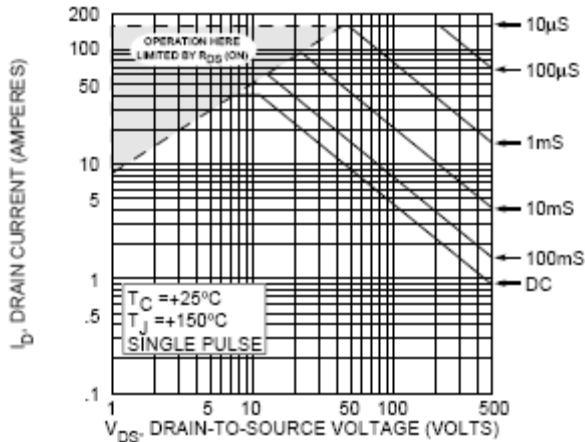

FIGURE 10, MAXIMUM SAFE OPERATING AREA

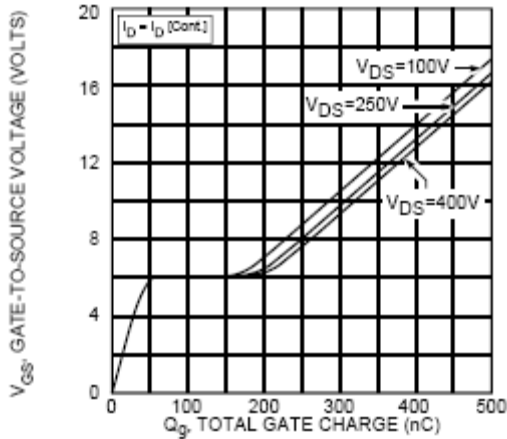

FIGURE 12, GATE CHARGES vs GATE-TO-SOURCE VOLTAGE

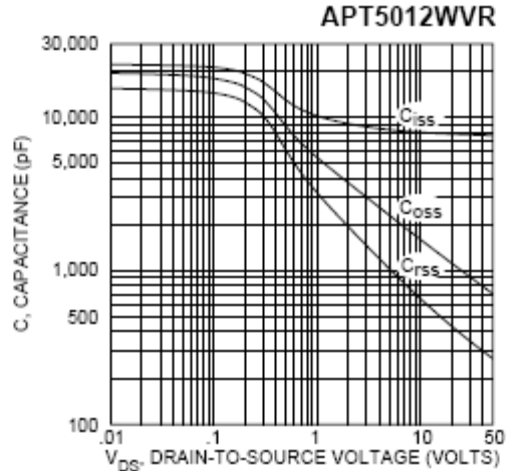

FIGURE 11, TYPICAL CAPACITANCE vs DRAIN-TO-SOURCE VOLTAGE

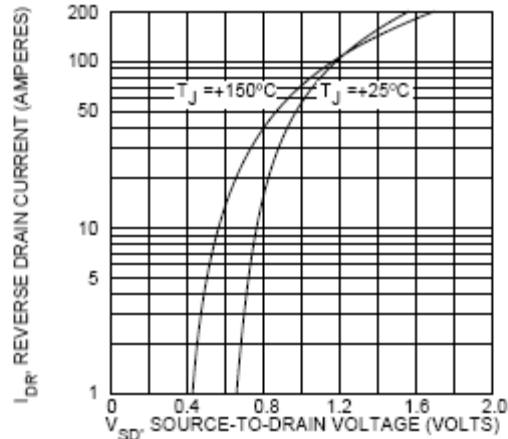
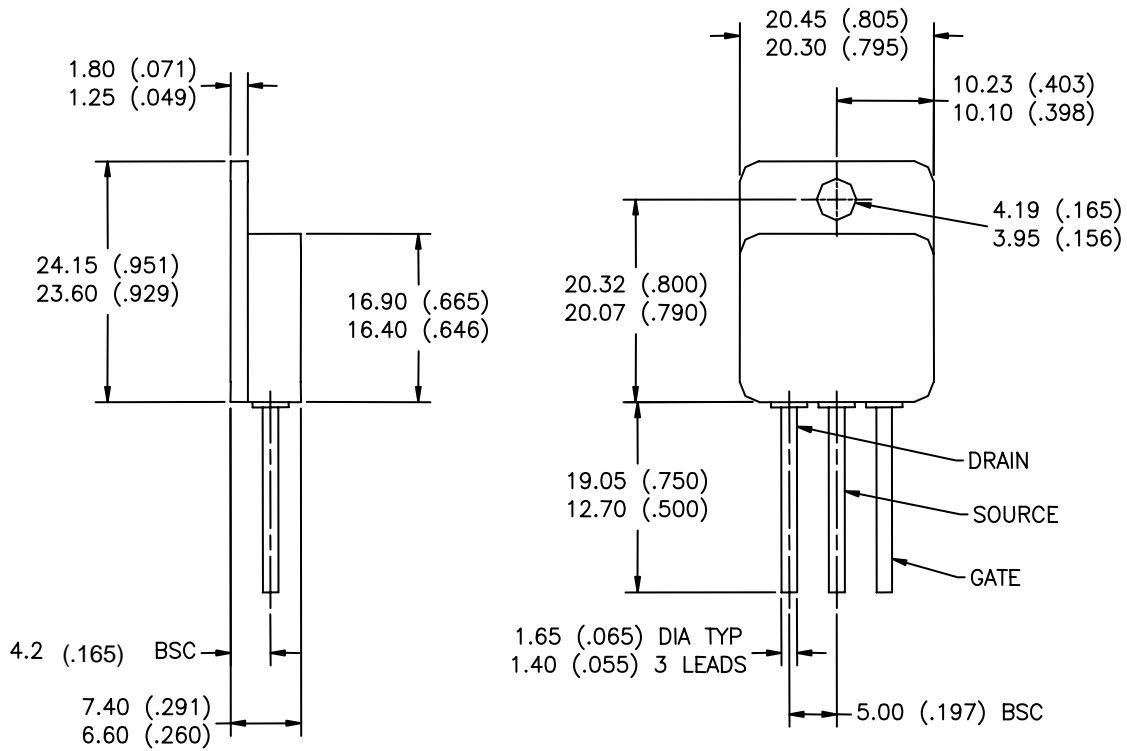

FIGURE 13, TYPICAL SOURCE-DRAIN DIODE FORWARD VOLTAGE

**PACKAGE DIMENSIONS**



DIMENSIONS IN MILLIMETERS AND (INCHES)