

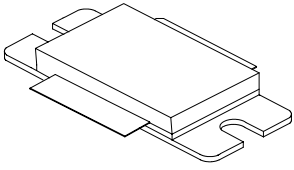

1011LD300

300 Watts, 32 Volts

Pulsed Avionics 1030 to 1090 MHz
LDMOS FET

<p>GENERAL DESCRIPTION</p> <p>The 1011LD300 is a COMMON SOURCE N-Channel enhancement mode lateral MOSFET capable of providing 300 W_{pk} of RF power from 1030 to 1090 MHz. The device is nitride passivated and utilizes gold metallization to ensure highest MTTF. The transistor includes input prematch for broadband capability. Low thermal resistance package reduces junction temperature, extends life.</p>	<p>CASE OUTLINE 55QM (Common Source)</p> 
<p>ABSOLUTE MAXIMUM RATINGS</p> <p>Power Dissipation Device Dissipation @25°C (P_d) 1590 W</p> <p>Voltage and Current Drain-Source (V_{DSS}) 75V Gate-Source (V_{GS}) ± 20V</p> <p>Temperatures Storage Temperature -65 to +150°C Operating Junction Temperature +200°C</p>	

ELECTRICAL CHARACTERISTICS @ 25°C

SYMBOL	CHARACTERISTICS	TEST CONDITIONS	MIN	TYP	MAX	UNITS
BV _{dss}	Drain-Source Breakdown	V _{gs} = 0V, I _d = 30mA	75			V
I _{dss}	Drain-Source Leakage Current	V _{ds} = 38V, V _{gs} = 0V			10	μA
I _{gss}	Gate-Source Leakage Current	V _{gs} = 10V, V _{ds} = 0V			2	μA
V _{gs(th)}	Gate Threshold Voltage	V _{ds} = 10V, I _d = 60 mA	3		6	V
V _{ds(on)}	Drain-Source On Voltage	V _{gs} = 10V, I _d = 3A			0.3	V
g _{FS}	Forward Transconductance	V _{ds} = 10V, I _d = 3A		3		S
θ _{JC} ¹	Thermal Resistance				.11	°C/W

FUNCTIONAL CHARACTERISTICS @ 25°C, V_{ds} = 32V, I_{dq} = 750mA

G _{PS}	Common Source Power Gain	Pulse width = 32 μs, LTDC=2% F=1030/1090 MHz, P _{out} = 300W	13	14		dB
P _d	Pulse Droop				0.5	dB
η _d	Drain Efficiency	F = 1030 MHz, P _{out} = 300W	43			%
ψ	Load Mismatch	F = 1090 MHz, P _{out} = 300W			3:1	

- NOTES: 1. At rated output power and pulse conditions
2. Pulse Format 1: 32μs, 2% Long Term Duty Factor

Rev. B – Apr 2004

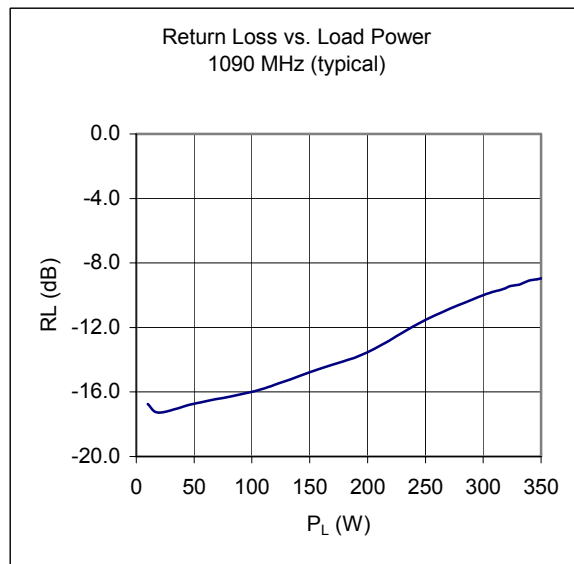
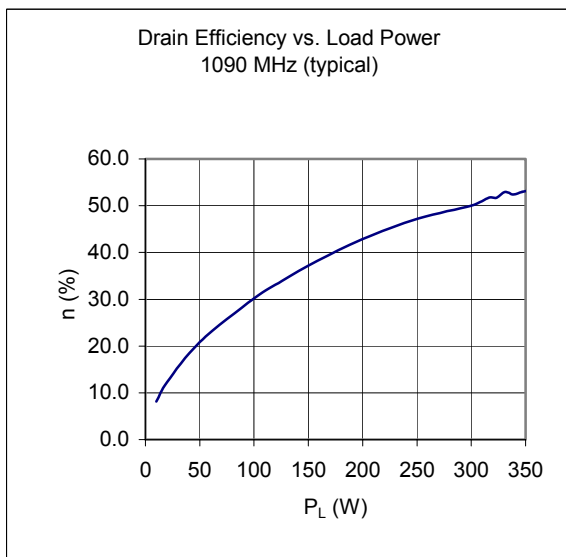
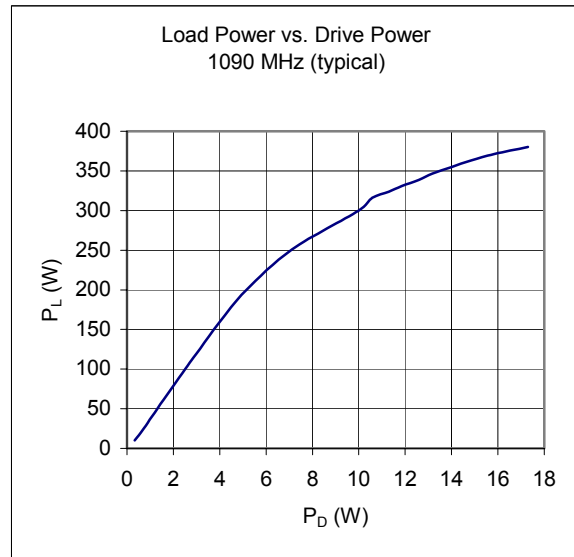
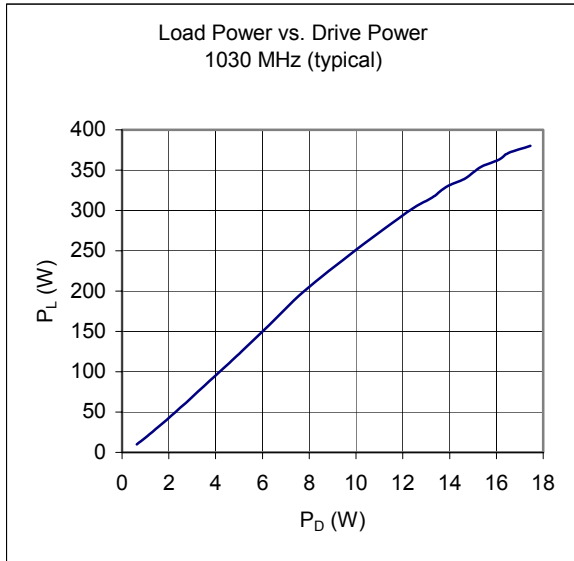

1011LD300

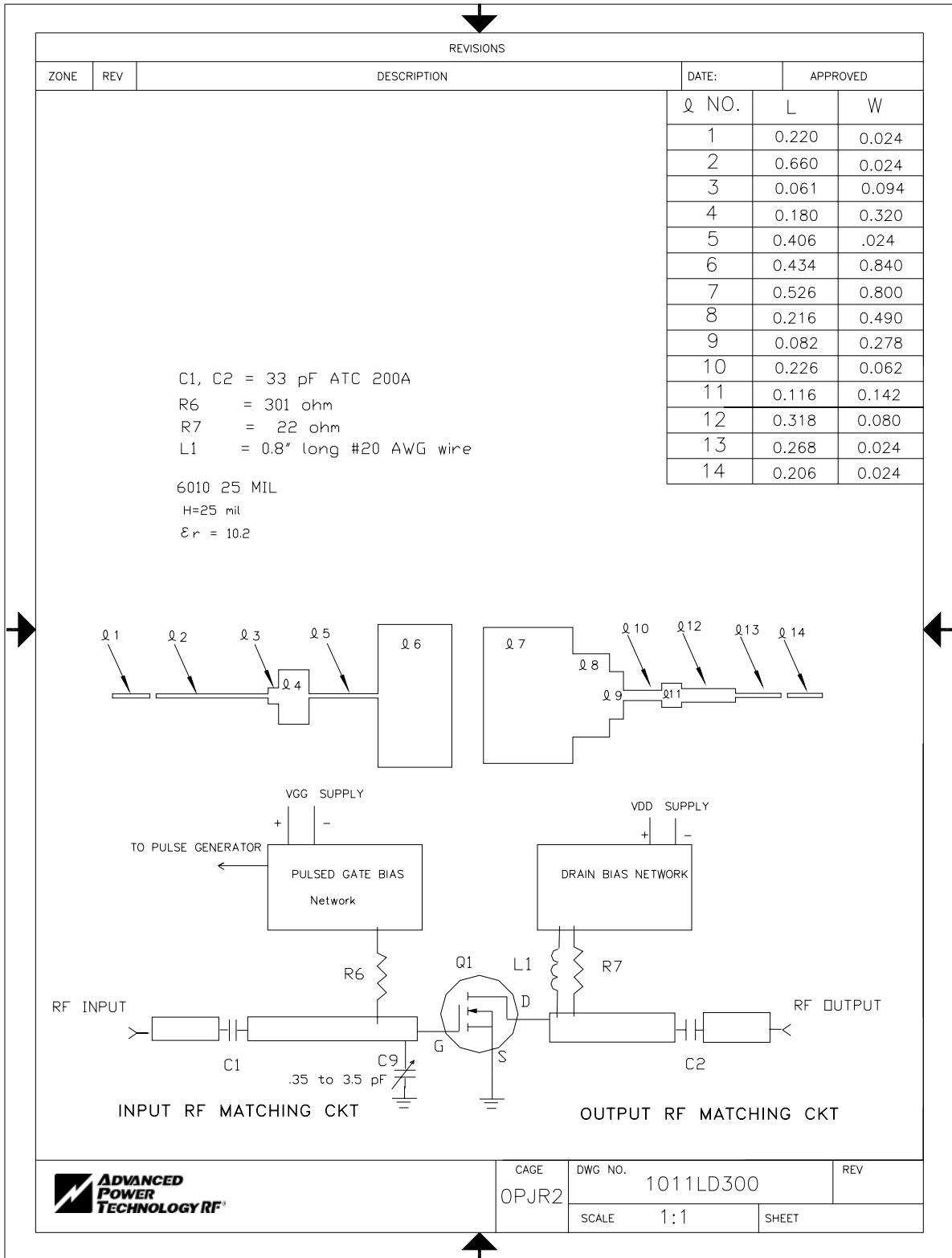

1011LD300

