

**ADVANCED
POWER
TECHNOLOGY®**

APT9801
By: Richard Frey, P.E.

APPLICATION NOTE

A Push-Pull 300 Watt Amplifier for 81.36 MHz

Reprinted from the April 1998 issue of
Applied Microwave and Wireless Magazine
courtesy of Noble Publishing Corporation

A Push-Pull 300-watt Amplifier for 81.36 MHz

This design uses low cost power FETs that bridge the gap between typical power devices and specialized RF devices

Richard Frey
Advanced Power Technology

Power amplifiers for 80 MHz have typically used expensive ceramic-metal packaged RF devices. The use of an inexpensive TO-247 packaged transistor with an innovative internal device connection provides the basis for the cost effective design presented here. This article describes a 300 watt amplifier for 81.36 MHz using a push-pull pair of plastic packaged devices. The design techniques and construction practices are described in enough detail to permit duplication of the amplifier.

Devices used in the amplifier

The devices used in the amplifier are the ARF449A and ARF449B symmetrical pair (see photo). These devices are targeted for high voltage, single frequency, class C operation. The operating voltage for the amplifier will be 125 volts. This was chosen as a compromise between the maximum available gain voltage and ruggedness when operating into high VSWR loads. These are a mirror-image connected pair of MOSFETs, each with the following characteristics:

BV_{dss} :	450 V
P_d :	165 W for $T_c = 25^\circ\text{C}$
$R_{ds(on)}$:	.72 ohm
C_{iss} :	980 pF
C_{oss} :	87 pF
C_{rss} :	25 pF

Because there are several different applications opportunities around 80 MHz, the second harmonic of the 40.68 MHz ISM (Industrial-Scientific-Medical) frequency allocation was chosen as the operating frequency. The design goals for the amplifier are:

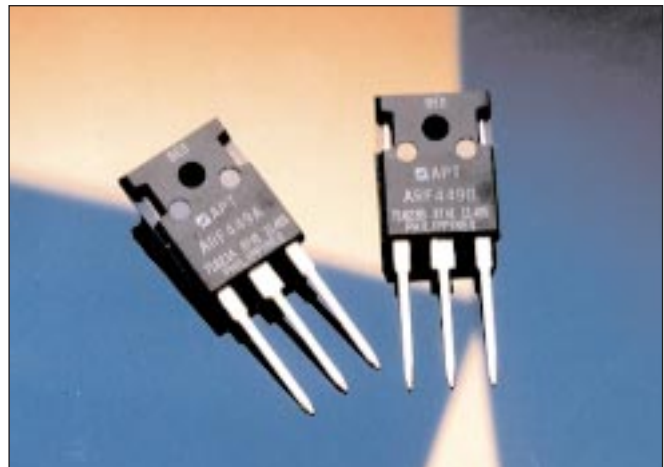

■ These low cost, plastic packaged power FET devices power the amplifier described in this article.

Frequency:	81.36 MHz
Output power:	300 W max. CW 600 W max. 50% duty cycle
Input VSWR:	< 2:1
Power gain:	> 12 dB
Efficiency :	> 70%
Harmonics:	< -30dBc

Amplifier description

The circuit is classic push-pull. The input transformer provides balanced drive to the gates through a balanced matching network. The gates are kept at ground potential by resistors on each side of the transformer secondary, although a single resistor at the secondary center tap would work as well. The output signals from each drain go through identical matching networks to a simple coax balun. The powdered iron coil form on the output balun lowers the loss which would otherwise be inherent in the

longer piece of coax required to obtain the minimum necessary common mode impedance.

Amplifier design

In order to make the amplifier easy to duplicate, the design makes minimum use of special parts and magnetic materials. Operation at 80 MHz is not without some challenge. At this frequency, the actual value of discrete parts is generally far from their marked value. Surface mount multi-layer capacitors with NPO dielectric are used. Initial attempts to use Z5U dielectric capacitors came to a spectacular end.

A single ended amplifier using the ARF449A was used to characterize the device and to determine the input and output characteristics. The input impedance was measured using a vector impedance bridge, but not without some difficulty. Z_{in} was determined to be $0.3 + j2.75$. This indicates that the internal lead bonding inductance, approximately 9 nH, is of greater magnitude than the 970 pF input capacitance. The output impedance was determined to be $9.14 - j12.6$.

Using this information, single ended matching networks for the amplifier were designed using commonly available Smith Chart software. Since neither of the software packages used will properly address a push-pull configuration, the matching circuits for the input and output were designed as single-ended, and the values obtained were transposed for the higher impedance, balanced configuration of push-pull.

The input matching design is shown in Figure 1. The winSmith [1] software package was used to select proper values for the components. The low impedance of the gate circuit makes it critical to maintain absolute symmetry in this area. In Figure 1, L1 is the leakage reactance of T1. C1 is the net capacitance of the input trimmer capacitor. It is a mica compression trimmer and care must be taken in selecting the size and value to assure it is operated well below its series resonant frequency. A suitable clad mica fixed capacitor could be substituted for C1 once the proper value is determined. TL1 is 0.2 inch wide or 35 ohms and is 1.80 inches long. The single ended design is changed to push-pull simply by duplicating the series elements on the mirrored side and reducing the shunt elements by half.

For the purpose of illustration in this paper, the winSmith screen image was captured, and the resulting bit map was edited to reduce the complexity of the display.

The input transformer design was chosen for its sim-

licity and relative ease of construction. Of several attempts using higher permeability material, multiple beads, and different conductor types, this proved to be the best performing and most consistent. The core used is a Fair-Rite [2] "multi-aperture core," part number 2843010402. The type 43 material has a μ_i of 850. This transformer is essential in providing a balanced drive to the gates of the MOSFETs. 3/16 inch diameter brass tubing was used for the secondary winding. Copper shim stock was used to form the connections to the brass tubing at each end of the transformer secondary. The two-turn primary winding is wound inside the tubing. This construction provides a very reproducible transformer

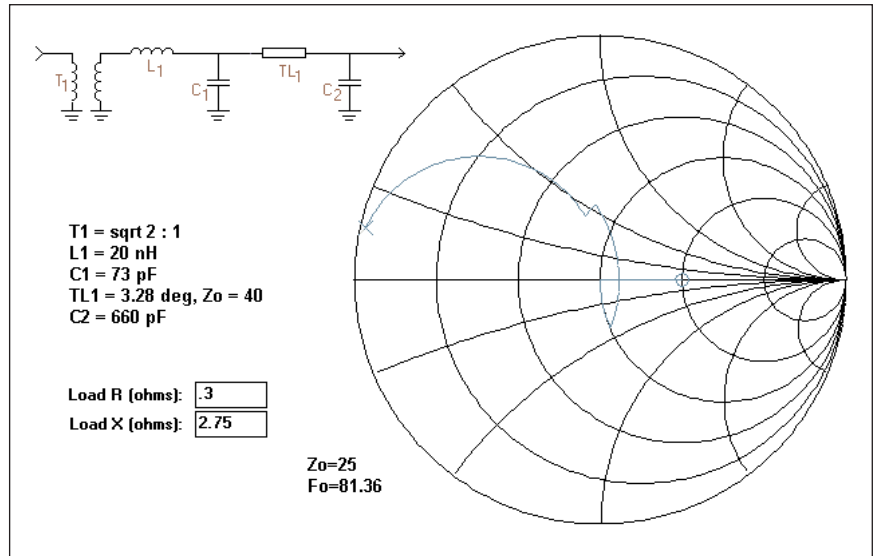

Figure 1. Amplifier input matching circuit.

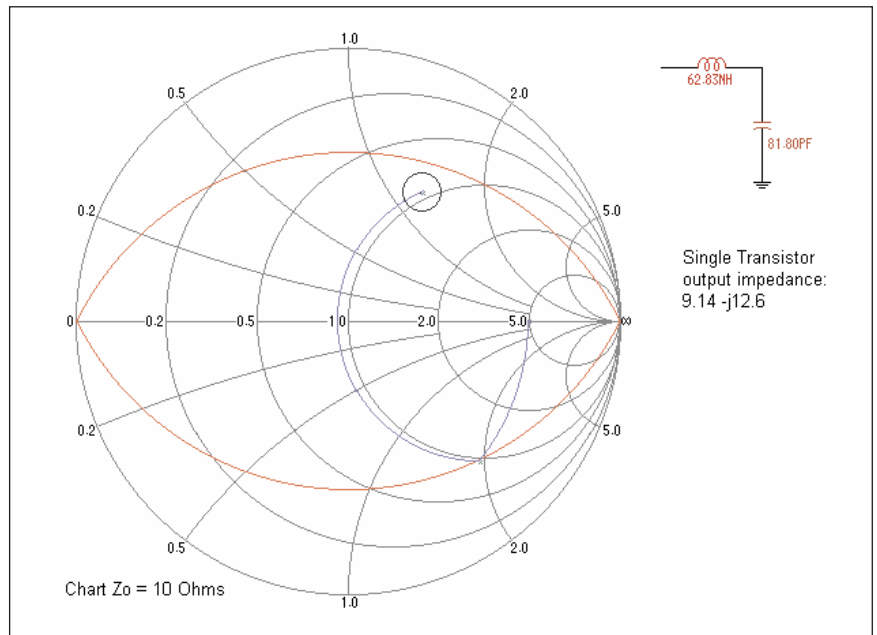

Figure 2. Amplifier output matching circuit.

with minimum leakage reactance and a very broad frequency response. It would be a suitable input transformer for a broadband amplifier covering 1 to 100 MHz.

Several amplifiers have appeared in the literature where the matching to the gate was done between the transformer and the 50 ohm drive point. The gates were connected directly to the secondary of the transformer. While this will surely produce a match to the driver, the transformer will not be operated at its design impedance, the losses will be much higher and, in the push-pull case, the balance will suffer. In this example, the gate impedance is matched to the 12.5 ohm transformer secondary impedance, plus strays.

Similarly, the output match was designed using MIMP [3]. The circuit and Smith Chart display are shown in Figure 2. The same 35 ohm microstrip line is used on the output side, and the 62.8 nH series value represents the combination of the short connection traces and the fixed coils. Both the DC feed chokes and the series tuning coils are wound with copper enameled wire on a 0.25-inch mandrel. The output tuning capacitor, also a mica compression trimmer, is located right at the balun connection.

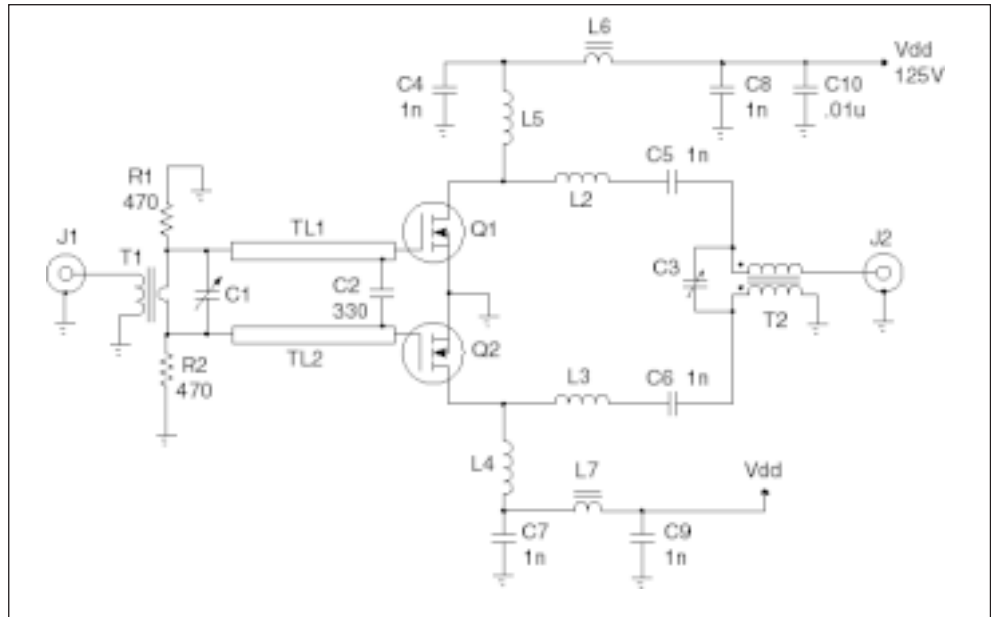

Figure 3. Amplifier circuit diagram.

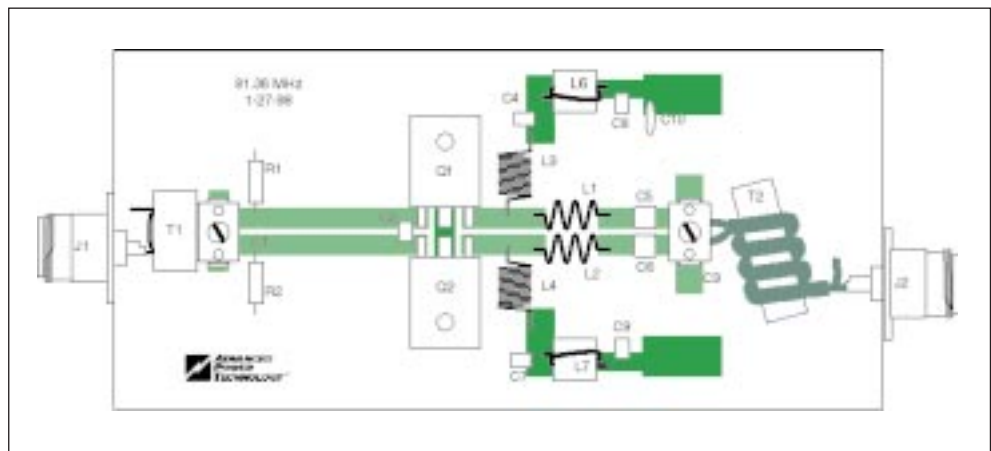

Figure 4. Parts placement pictorial diagram.

Construction

Figure 3 shows the schematic for the 81.36 MHz amplifier. The parts placement is illustrated in Figure 4. No particular effort was made to reduce the size. A photomaster of the printed circuit board is shown in Figure 5. The original size of the artwork is 7 x 3.25 inches. The amplifier is built on 1 oz. double-sided 1/16-inch G-10 printed circuit board material. All four edges of the board and three sides of the rectangular device openings are wrapped with copper tape and then soldered in place to provide a low

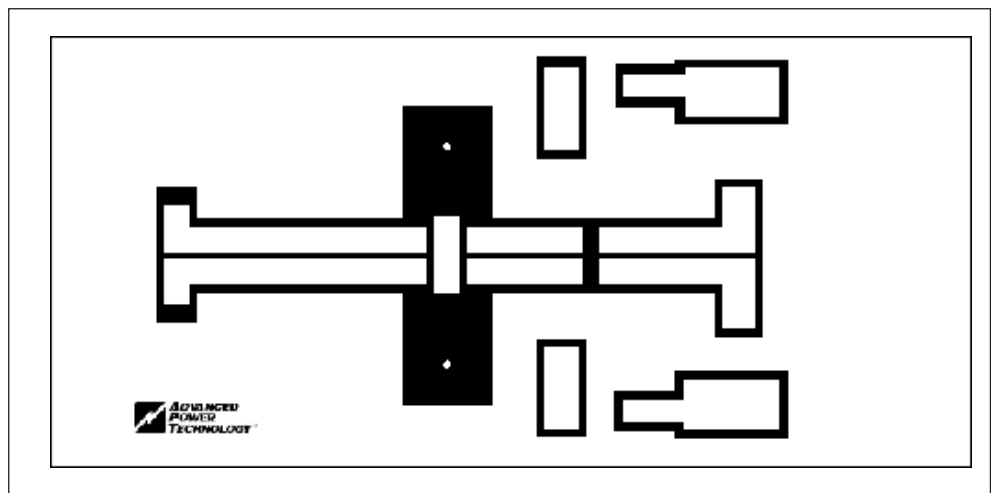
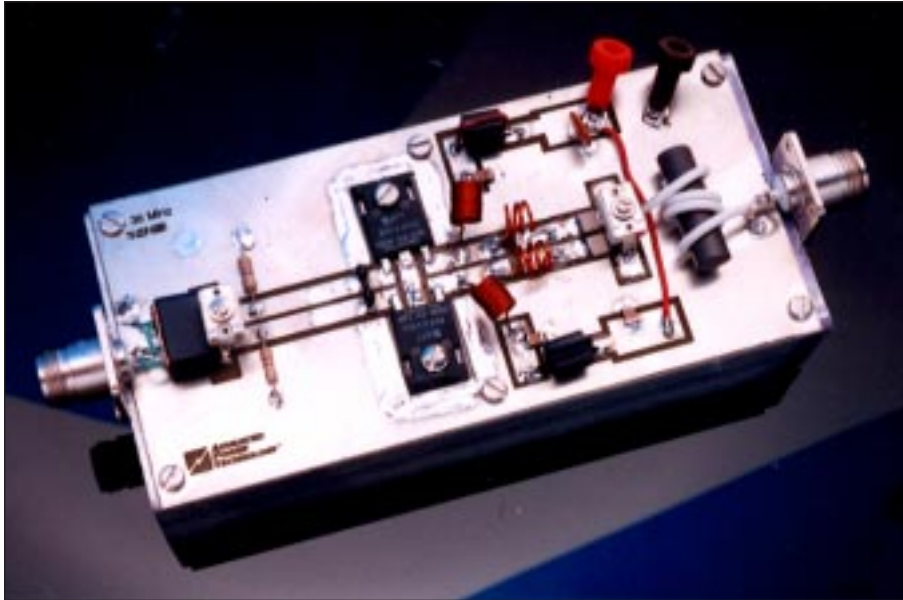

Figure 5. PWB photomaster. (Note: Not to scale)



■ Photo of the amplifier, showing the construction techniques and layout.

C1	75-380 pF ARCO 465
C2	330 pF clad mica
C3	25-115 pF ARCO 406
C4-C9	1 nF 500 V NPO chip, KD Components 2020N102J501P
C10	.01 μ F 1 kV
L1-L2	50 nH, 3t #18 enam. .25" dia.
L3-L4	.68 μ H 12t #24 enam .25" dia.
L5-L6	2t #20 on Fair-Rite 264006302 bead
Q1	ARF449A
Q2	ARF449B
R1-R2	470 ohm 1W 5%
T1	Pri: 2t #20 PTFE, Sec: 3/16" Brass tube on: Fair-Rite Products#2843010402 balun core.
T2	4t RG-316 coax on .375" x 1.25" powdered iron form
TL1-TL2	Printed line

■ Amplifier parts list

impedance continuous ground plane. Provided the edges are properly taped, no eyelets or plated-through holes are required to achieve the rated performance of the amplifier. An additional wrap of copper tape is required at the source contacts of each transistor. This provides the DC current return only; it is not part of the RF path.

The heat sink extrusion is a 7-inch length of AAVID #60765 [4]. It is 3.25 inches wide and 1.5 inches deep and has nine fins. At least 50 CFM of air blown through the finned sink area is required for sustained 250 W CW operation. The transistors are mounted directly to the heat sink through two rectangular holes in the circuit board.

Performance measurements

The performance of the amplifier at 81.36 MHz with 125 volts on the drain is illustrated in Figures 6 through 11. Figure 6 is a plot of input power versus output power. Figure 7 shows the efficiency versus gain characteristics. Figure 8 illustrates the gain versus output power. These data are for 300 watt CW operation. Figures 9-11 are the same plots for operation at 600 watts, 50 percent duty cycle. The maximum gain is 12.5 dB. When operating on the 50 percent duty cycle mode, a slight adjustment of C3 is needed to cause the efficiency to peak at 600 W. All harmonics are more than -40 dB. This performance is typical for an amplifier of this type. What makes it remarkable is that the devices are

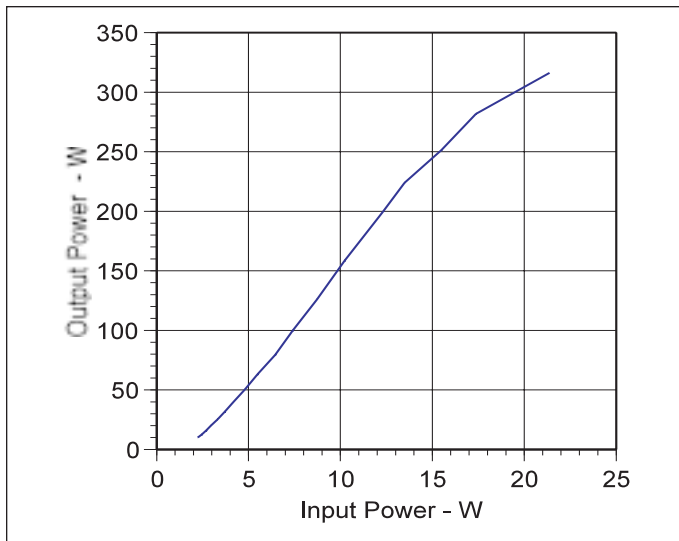

■ Figure 6. Output power vs. input power with the amplifier set up for 300-watt CW operation.

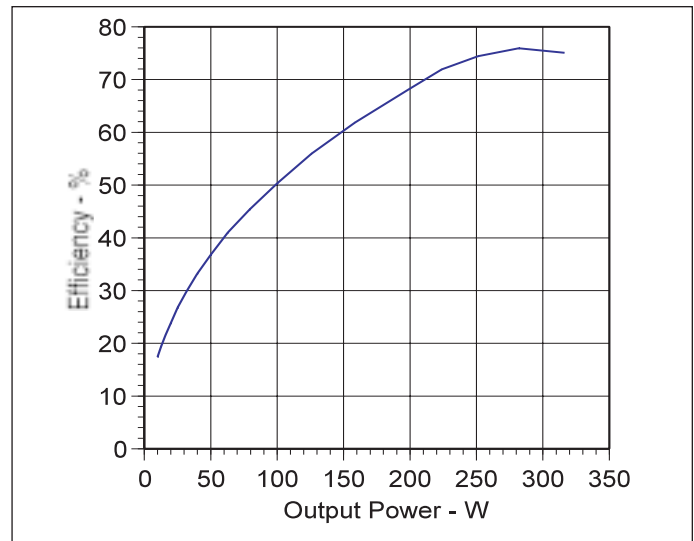

■ Figure 7. Efficiency for CW operation.

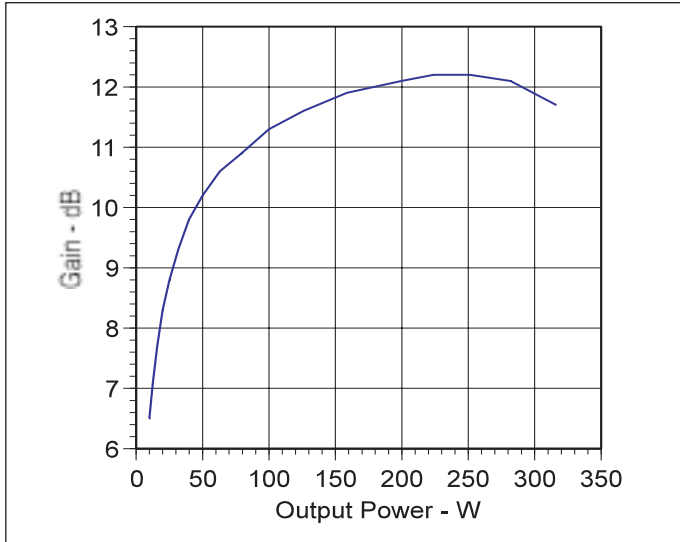

■ Figure 8. Gain of the amplifier during CW operation.

inexpensive plastic packaged MOSFETs and the voltage is more than twice that typically used for transistors at this frequency.

Conclusion

The single stage amplifier described produces more than 12 dB gain with over 250 watts of output power at the design frequency of 81.36 MHz. The design considerations for the matching of the device for best gain

were discussed along with a detailed description of the essential parts. ■

Acknowledgement

The author would like to thank Jeff Morrison for his assistance with amplifier construction and in gathering the data presented in this article.

References

1. winSmith is available from Noble Publishing Corp., 4772 Stone Dr., Tucker, GA 30084, tel: 770-908-2320.
2. Fair-Rite Products Corp., P.O. Box J, One Commercial Row, Walkill, NY 12589.
3. MIMP is available from the Motorola RF Products Group.
4. AAVID Thermal Technologies, Inc., Box 400, Laconia, NH 03247.

Author information

Richard Frey received a BSEE from Grove City College in 1968 and has 25 years experience in HF and VHF radio and broadcasting systems design. He is Senior Applications Engineer, responsible for RF product development and customer applications engineering, at Advanced Power Technology, 405 S.W. Columbia St., Bend, OR 97702; tel: 541-382-8028; fax: 541-330-0694; e-mail: dfrey@advancedpower.com.

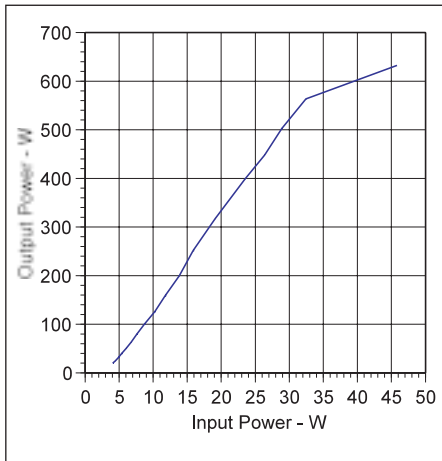

■ Figure 9. Output power vs. input power, 50 percent duty cycle, 600 watt operation.

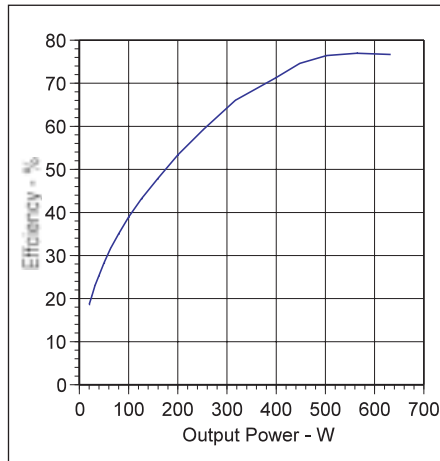

■ Figure 10. Efficiency for 50 percent duty cycle, 600 watt operation.

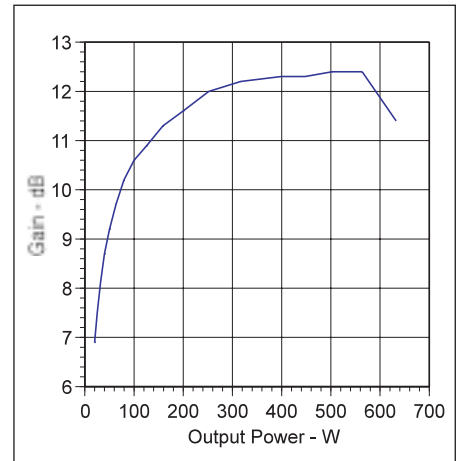

■ Figure 11. Gain of the amplifier during 50 percent duty cycle operation.