

# AN 23

# LED DRIVER APPLICATIONS FOR PORTABLE PRODUCTS

Application Engineer: Michael Calvert



## 1.0 INTRODUCTION

Light Emitting Diodes (i.e., LEDs) have played a pivotal role in electronics for many years and have found their way into a broad range of applications. Recent advances in LED technology have provided designers with small form factor and cost effective blue and white LEDs that support various lighting applications (e.g., display lighting). Liquid Crystal Displays (LCD) have emerged as the primary technology used in a variety of devices such as cellular telephones, personal digital assistants (PDA), and computer monitors. LCD technology comes in monochrome and color topologies using either passive or active matrix formats depending upon speed and resolution requirements. These displays require some form of external lighting source to allow the user to see the information on the display. Medium to large sized displays have relied on the benefits of fluorescent lighting to produce a bright white light that supports viewing the display in bright ambient lighting conditions. A clean white-light source is also necessary for viewing color LCD. The PDA uses a smaller LCD and a fluorescent lamp for panel illumination. However, many PDA manufacturers have moved to using white LEDs to back or side-light the color LCD. The reasons for migration from a fluorescent lamp to LED technology include cost reduction, enhanced reliability, and Electromagnetic Interference (EMI) reduction. Cellular telephones have long used LEDs for both display and keypad lighting. The market trend toward cell phones that provide a host of features (i.e., information management, games, and digital photography) now require a larger color LCD thus necessitating the use of white LEDs for effective illumination. Based upon the recent trend towards implementing white LEDs in LCD display applications, several semiconductor manufacturers have created a multitude of products designed to effectively illuminate LEDs in portable applications.

Illuminating LCD applications using white LEDs requires maintaining consistent brightness and chromaticity over the LED's operating current range. A light-pipe and diffuser are common elements in the LCD reflector assembly and necessary to achieve uniform distribution of LED light across the display. These mechanical elements absorb some portion of the LEDs optical output and can affect the color balance of the white light itself. System designers

must choose the optimal quantity of LEDs to effectively illuminate the display, work with LED manufacturers to obtain production quantities that are binned to meet both brightness and chromaticity requirements, and select the optimal LED drive method to support cost, performance, and power budget requirements.

Biasing an LED is not a difficult design task. A voltage source that attains the diode's forward voltage along with a series-connected resistor to set the forward current complete the drive requirements (see Figure 1). White LEDs used in today's portable applications have a typical forward voltage of 3.6v and achieve maximum brightness at their full rated forward current (i.e., typically 20mA DC). However, the challenge in LCD lighting applications centers on achieving uniform brightness and chromaticity across the display while using the least number of LEDs to accomplish the task.

The designer that is tasked with lighting a typical color Super Twisted Neumatic (STN) or Thin Film Transistor (TFT) display in a portable application will typically require from 2 to 10 white LEDs to ensure enough brightness in all lighting conditions. The actual number of LEDs required also depends upon the type of display (i.e., reflective, transmissive, or transmissive) and the integrity of the light diffuser assembly.

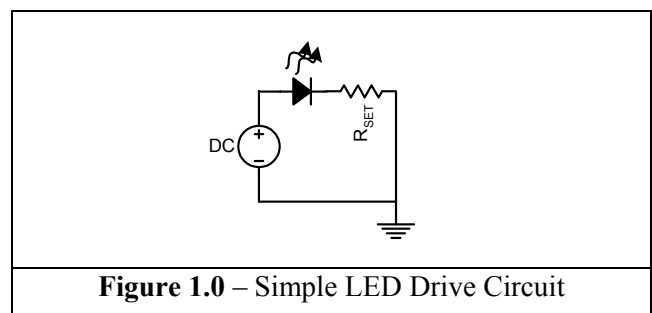

Figure 1.0 – Simple LED Drive Circuit

## 2.0 LED DRIVE METHODS

There are several ways to drive LEDs and each method has positive and negative attributes. Portable applications that require multiple LEDs, brightness control (i.e., dimming), and uniform LED performance typically choose from one of three methods to drive the devices (i.e., controlled current source, charge pump, or inductor-based boost converter). *Microsemi* offers solutions for each of these LED drive methods.



Microsemi offers the **LX1882** as a charge pump solution for low-power boost applications such as driving LEDs. The LX1882 is a charge pump with a built-in low drop-out regulator (LDO) and operates from an input voltage source up to 5VDC. The internal LDO reduces switching noise at the output making the LX1882 attractive for noise sensitive applications. Output voltage is adjustable from 2.5 to 5.5VDC and the maximum output current is 50mA; thus 3 LEDs could be driven with a forward current of 15mA each. Figure 4 shows the LX1882 in a typical LED driver application.

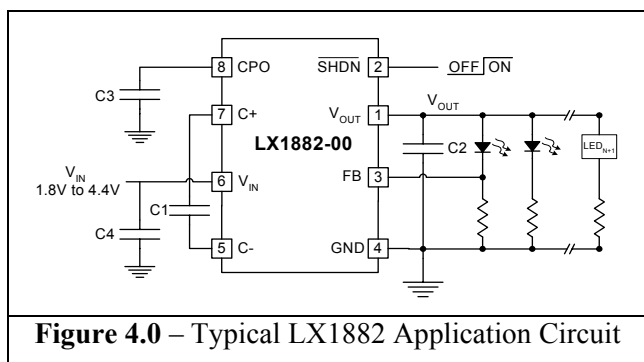

**Figure 4.0** – Typical LX1882 Application Circuit

#### Method 3: Inductor-Based Boost Converter.

This method uses a switched-mode boost converter circuit that operates in either a pulse-width modulated (PWM) or pulse-frequency modulated (PFM) topology. This topology requires an inductor and output capacitor for the energy storage elements, runs from a single input voltage, and is typically capable of stepping-up the output voltage over 5X the input voltage. The advantages associated with an inductor-based boost topology include large output voltage, higher output current and superior conversion efficiency over a wide input voltage range. The disadvantages associated with this topology include higher cost, higher levels of EMI, and greater design complexity. PWM based solutions provide a fixed switching converter frequency spectrum that can simplify design requirements for EMI suppression. However, PWM boost topologies typically offer reduced efficiency performance at low output currents. This becomes an issue when a display system requires the brightness to be varied over some range and LED forward current drops below 15mA. Here, the PFM topology offers superior efficiency performance. The PFM architecture reduces the converter's switching frequency to accommodate the lighter current load. As the converter's switching

frequency is reduced, the losses associated with the power conversion process are also reduced thereby providing higher efficiency at light-load versus the PWM topology. Microsemi offers the **LX1992** and **LX1993** LED Drivers as PFM controllers that provide designers with a cost-effective solution for a variety of display lighting applications.

#### LX1992 and LX1993 Features

The LX1992 and LX1993 are very similar devices. The essential difference between these two controllers is that the LX1992 uses an external MOSFET whereas the LX1993 includes the MOSFET internally. This difference allows the LX1992 to achieve higher output voltage than the LX1993 with some improvement in conversion efficiency. However, the LX1993's internal MOSFET lowers design cost and improves system-level reliability. This device has 8 functional pins that are designated as IN (voltage input), OUT (voltage output), CS (current sense – used to set the peak inductor current limit), SHDN (active-low shutdown – disables the controller and reduces supply current to  $< 1\mu\text{A}$ ), GND (circuit ground), FB (feedback – a resistor divider network is connected between this pin and ground to establish  $V_{\text{OUT}}$ ), ADJ (adjust – provides for external control of the output voltage by up to  $\pm 15\%$ ), and SW (switch – inductor output & diode input connection; this pin is high impedance in shutdown mode). Figure 5.0 illustrates a typical LX1993 application circuit. Several design considerations apply to the selection of the inductor, capacitors, and diode. For example, the designer can minimize inductor size, input ripple current, and output ripple voltage by setting the peak inductor current level to approximately 2X the expected maximum DC input current. Low ESR capacitors are recommended because they reduce ripple induced by the switching current. Multi-layer ceramic capacitors with X5R or X7R dielectric are a superior choice because they feature small size, very low ESR, and a temperature stable dielectric. Low ESR electrolytic capacitors such as solid tantalum or OS-CON types are also acceptable. When choosing the diode, the designer should consider the device's average and peak current ratings with respect to the application's output and peak inductor current requirements. Moreover, the diode's reverse breakdown voltage characteristic must be capable of withstanding a negative voltage transition that is greater than  $V_{\text{OUT}}$ . A properly sized Schottky diode

will typically meet these requirements for a broad range of applications.

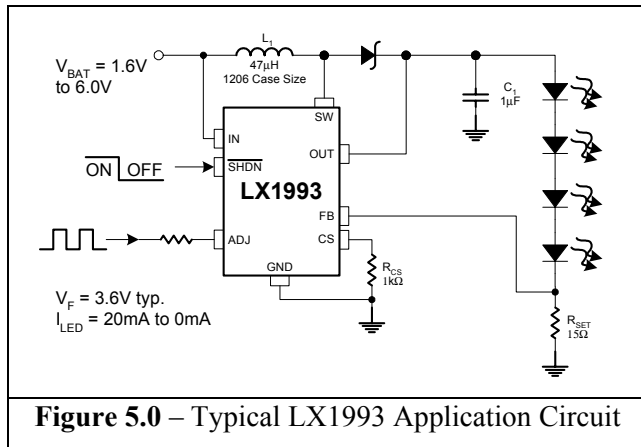

Figure 5.0 – Typical LX1993 Application Circuit

3.0 LX1993 DESIGN EXAMPLE

Let’s work through a typical application for the LX1993 (i.e., where T<sub>A</sub> = 25°C). The application requires driving 5 white LEDs from a 3.6v source (**note:** the LX1993 could drive any color LED provided that the maximum series string voltage, or # of LEDs x V<sub>F</sub>. does not exceed 25.0V). The maximum forward voltage of a white LED can be as high as 3.9v. We wish to connect the LEDs in series (i.e., 5 x 3.9v = 19.5v) so that the same current will flow through each diode thus minimizing variance in brightness and chromaticity over the forward current operating range. First, we need to determine the Peak Inductor Current (I<sub>PEAK</sub>) required for this application. Therefore, we will start by determining the input current I<sub>IN</sub> using the efficiency equation where Output Power (P<sub>OUT</sub>) is equal to the Efficiency (η) multiplied by the Input Power (P<sub>IN</sub>).

$$P_{OUT} = \eta(P_{IN}) \tag{1.0}$$

Recall that power is equal to voltage multiplied by current (i.e., p = vi). Therefore, we can rewrite the efficiency equation and solve for I<sub>IN</sub> where, V<sub>IN</sub> equals 3.6V, V<sub>OUT</sub> equals 19.5V, I<sub>OUT</sub> equals 15mA (maximum) and η is estimated from the device’s efficiency versus output current curve (see datasheet). An efficiency value of 0.75 is a reasonable approximation. The LX1993 maintains a regulated output when operating in the discontinuous mode (i.e., inductor current goes to zero between switching cycles). Therefore, we’ll choose a duty cycle of 0.85 to provide sufficient margin over the operating range. Now, I<sub>IN</sub> may be estimated as follows:

$$I_{IN} = \left( \frac{I_{OUT} * V_{OUT}}{\eta * V_{IN}} \right) = \left( \frac{15mA * 19.5V}{0.75 * 3.6V} \right) = 108mA \tag{2.0}$$

We are ready to calculate the peak inductor current now that the input current is estimated. I<sub>PEAK</sub> is a function of several parameters, specifically: I<sub>MIN</sub>, V<sub>IN</sub>, L, t<sub>D</sub>, I<sub>SCALE</sub>, and R<sub>CS</sub>. V<sub>IN</sub> is already defined herein as 3.6V and the LX1993 data sheet provides values for the nominal I<sub>MIN</sub> and I<sub>SCALE</sub> value of 197mA and 44mA/kΩ respectively. The parameter t<sub>D</sub> is a switching delay related to the operation of the feedback comparator circuit (see Block diagram in data sheet). A typical value for t<sub>D</sub>, at 25°C, is 850ns. *Microsemi* recommends an inductor (L) value of 47µH as this provides effective performance over a broad power conversion range. A higher inductance value may improve efficiency at the expense of degrading the overall output voltage ripple performance. Inserting a smaller inductance value will degrade efficiency. Moreover, the designer is encouraged to consider I<sub>PEAK</sub> variation over the input voltage range as a smaller inductance *increases* I<sub>PEAK</sub> variation versus a larger inductance. Using this information, we can determine the R<sub>CS</sub> value required to set the I<sub>PEAK</sub> value for this application. From our previous calculation, I<sub>IN</sub> was determined to be 108mA. We will multiply this value by a factor of 2 to ensure that we have sufficient margin over temperature and device-to-device variability hence reducing the risk of hitting current-limit (continuous-mode operation). Therefore, I<sub>PEAK</sub> = 2(I<sub>IN</sub>) = 2(108)mA = 216mA < 500mA<sub>RMS</sub> (I<sub>SRC</sub>). **Note:** The maximum I<sub>PEAK</sub> value is limited by the I<sub>SRC</sub> value (max. = 0.5A<sub>RMS</sub> : LX1993).

Now we can solve for R<sub>CS</sub> by using formula 4.0 where:

$$I_{PEAK} = I_{MIN} + \left( \frac{V_{IN}}{L} \right) t_D + (I_{SCALE} * R_{CS}) \tag{3.0}$$

Solving for R<sub>CS</sub> yields equation 4.0:

$$R_{CS} = \left( \frac{1}{I_{SCALE}} \right) \left( I_{PEAK} - I_{MIN} - \left( \frac{V_{IN}}{L} \right) t_D \right) \tag{4.0}$$

Inserting values into equation 4.0 yields:

$$R_{CS} = \left( \frac{1}{44mA/k\Omega} \right) \left( 216mA - 197mA - \left( \frac{3.6V}{47\mu H} \right) 850ns \right) = -1044\Omega$$

The result produced a negative value. This indicates that the appropriate value for R<sub>CS</sub> is 0Ω because a current sense resistor value of zero ohms yields a

minimum *peak* current of 262mA – this is more than adequate for this application. Therefore, pin 6 should be tied to ground.

**4.0 Design Tools**

A simple Excel™ spreadsheet is available at our website to help you quickly assess the impact of varying the design parameters for a particular application (i.e., see website: **LX1992 / 1993 Formula Calculator for AN23**). The spreadsheet contains two sheets titled 1992 and 1993. The calculator allows the designer to input values for output voltage, output current, input voltage, output capacitance, inductance, output voltage selection resistor  $R_2$ , and the current limit resistor  $R_{CS}$ . The calculator returns values for estimating output voltage ripple (as a function of droop and overshoot), the output voltage selection resistor  $R_1$ , the peak current, and the output power. The value of peak current is also calculated at  $R_{CS} = 0\Omega$  for reference. Now some words of advice: the validity of calculator’s output is dependent upon the validity of the input data. Therefore, here are some guidelines for selecting input values.

- The Inductor (L) value of 47μH is presented as a starting point for most application circuits. Remember that selecting the inductor value requires making trade-offs. For example, the inductance value should be sufficient to ensure proper energy storage under worst-case input voltage and on/off-time conditions. Further, the inductor core

must not go into saturation. Second, the designer should minimize the device’s DC resistance to reduce power loss (thus improving overall efficiency). System-level

- EMI, cost, and mechanical size are other factors that influence inductor selection criteria. Inductance values from 20μH to 100μH will support a broad range of applications. Note that small inductor values tend to increase peak current variance due to deviations in the mean value of the comparator delay ( $t_D$ ).
- The value of the current limit resistor ( $R_{CS}$ ) directly affects the value of peak current. The LX1992 and LX1993 have an absolute maximum switch current rating of 800mA(RMS) and 500mA(RMS) respectively. Do not exceed these values. Always use the smallest current limit resistor value that your design can tolerate. Setting the peak current excessively high burns away power and reduces overall efficiency (and battery life!). These LED drivers are designed to support applications that have an output requirement of less than 1.5W. Use this as your guideline.
- Input voltage is simple. Do not exceed 6.0V. Start-up is guaranteed at 1.6V for very light loads.
- Cost and the output voltage ripple essentially define the output capacitor type and value. These two constraints will allow the designer to determine what value makes sense.

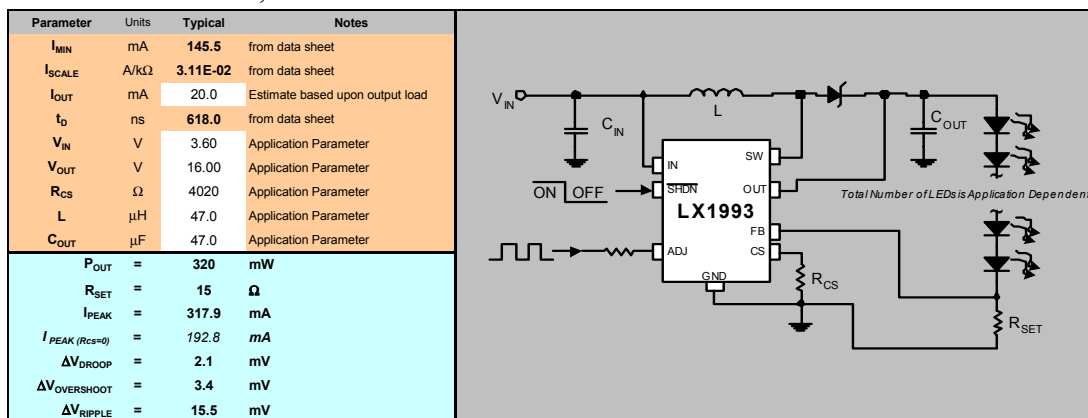

Figure 6.0: LX1993 Formula Calculator Spreadsheet

Example Application Circuits Using the LX1992 Evaluation Board Platform

