

## 5.15–5.85GHz 802.11ac Front End Module

### Description

The LX5586H is a complete integrated 5GHz Front-End Module (FEM) for an IEEE 802.11ac system. It includes a highly linear 5GHz Power Amplifier (PA) with power detector, Low Noise Amplifier (LNA) with bypass capability, and SPDT antenna switch. This highly integrated FEM only requires one bypass cap thus reducing system footprint, bill of materials, and manufacturing cost.

The LX5586H is available in a 16-pin low profile 2.5x2.5x0.45mm QFN Package.

### Features

- 5V Supply Voltage
- Integrated 5GHz PA, LNA, and SPDT Tx/Rx Switch
- POUT = 19dBm (typical) at -36dB EVM (256QAM/80MHz)
- Bypassable Low Noise Figure LNA
- Small Footprint: 2.5 x 2.5mm<sup>2</sup>
- Low Profile: 0.45mm max
- RoHS Compliant & Halogen Free

### Applications

- Tablets
- Access Points
- Mobile Devices
- Notebooks
- Gaming

### Block Diagram

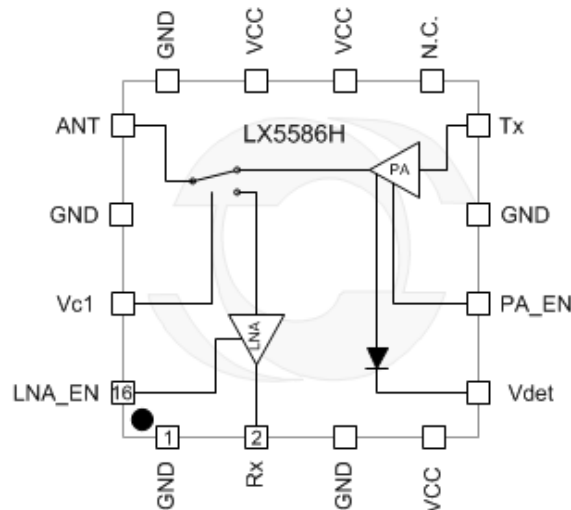
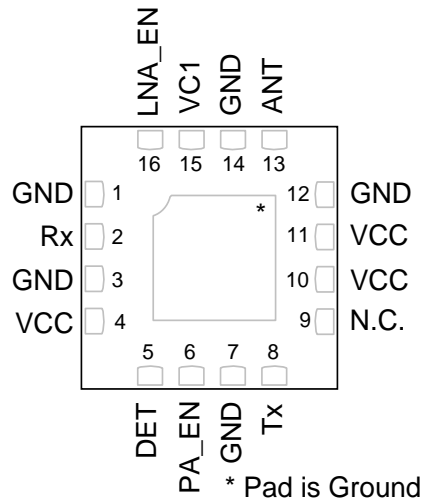

Figure 1 • Functional Block Diagram

## Pin Configuration



**Figure 2** · Pinout (Top View)

## Ordering Information

Ambient Temperature	Type	Package	Part Number	Packaging Type
-40°C to 85°C	RoHS2 compliant, Pb-free NiPdAu lead finish	QFN 2.5x2.5x0.45 16L	LX5586HLL	Bulk / Tube
			LX5586HLL-TR	Tape and Reel



**Microsemi Corporate Headquarters**  
One Enterprise, Aliso Viejo,  
CA 92656 USA

**Within the USA:** +1 (800) 713-4113  
**Outside the USA:** +1 (949) 380-6100  
**Sales:** +1 (949) 380-6136  
**Fax:** +1 (949) 215-4996

**E-mail:** [sales.support@microsemi.com](mailto:sales.support@microsemi.com)

© 2017 Microsemi Corporation. All rights reserved. Microsemi and the Microsemi logo are trademarks of Microsemi Corporation. All other trademarks and service marks are the property of their respective owners.

Microsemi Corporation (Nasdaq: MSCC) offers a comprehensive portfolio of semiconductor and system solutions for communications, defense & security, aerospace and industrial markets. Products include high-performance and radiation-hardened analog mixed-signal integrated circuits, FPGAs, SoCs and ASICs; power management products; timing and synchronization devices and precise time solutions, setting the world's standard for time; voice processing devices; RF solutions; discrete components; security technologies and scalable anti-tamper products; Power-over-Ethernet ICs and midspans; as well as custom design capabilities and services. Microsemi is headquartered in Aliso Viejo, Calif., and has approximately 3,400 employees globally. Learn more at [www.microsemi.com](http://www.microsemi.com).

Microsemi makes no warranty, representation, or guarantee regarding the information contained herein or the suitability of its products and services for any particular purpose, nor does Microsemi assume any liability whatsoever arising out of the application or use of any product or circuit. The products sold hereunder and any other products sold by Microsemi have been subject to limited testing and should not be used in conjunction with mission-critical equipment or applications. Any performance specifications are believed to be reliable but are not verified, and Buyer must conduct and complete all performance and other testing of the products, alone and together with, or installed in, any end-products. Buyer shall not rely on any data and performance specifications or parameters provided by Microsemi. It is the Buyer's responsibility to independently determine suitability of any products and to test and verify the same. The information provided by Microsemi hereunder is provided "as is, where is" and with all faults, and the entire risk associated with such information is entirely with the Buyer. Microsemi does not grant, explicitly or implicitly, to any party any patent rights, licenses, or any other IP rights, whether with regard to such information itself or anything described by such information. Information provided in this document is proprietary to Microsemi, and Microsemi reserves the right to make any changes to the information in this document or to any products and services at any time without notice.