

101302C

FB(327.5+n*20)-20, n= -3 to 3 Channelizer Multiple Output Filter Module

Specifications

Parameter	Symbol	Unit	
Filter Component			101551
Center Frequency	F_0	MHz defined	327.5
Bandwidth	B	MHz defined	20
-3dB Bandwidth	B_3	MHz min	20
-40dB Bandwidth	B_{40}	MHz max	60
Delay	T_0	μ sec typ	0.505
Amplitude Ripple		dB _{P-P} max	2
Phase Ripple		deg _{P-P} max	6
Rejection		dB max	-55
Spurious for $ t - T_0 > .9T_0$		dB max	-65
Gain		dB min	-7
Power In for -1 dB Comp		dBm min	4
Noise Figure		dB max	18
Return Loss		dB min	10
DC Power	12V @ 480mA		

Notes

Multiple Output Filter Module. Specifications show n for $F_0 = 327.5$ MHz only (J5). Additional channels have $F_0 = 327.5 + n * 20$, for $n = -3$ to 3.

1. Amplitude Ripple is Deviation from Best Fit Gaussian over 2B.

System Block Diagram

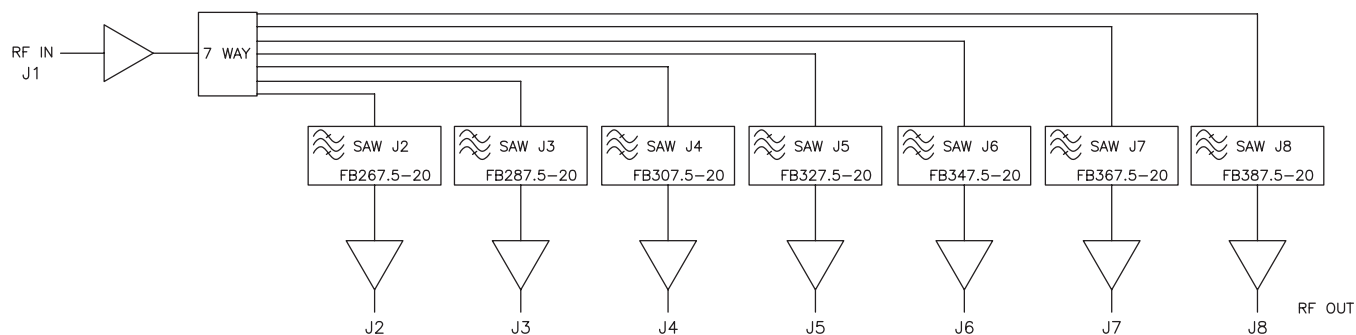

101302C

FB(327.5+n*20)-20, n= -3 to 3 Channelizer Multiple Output Filter Module

Package Outline

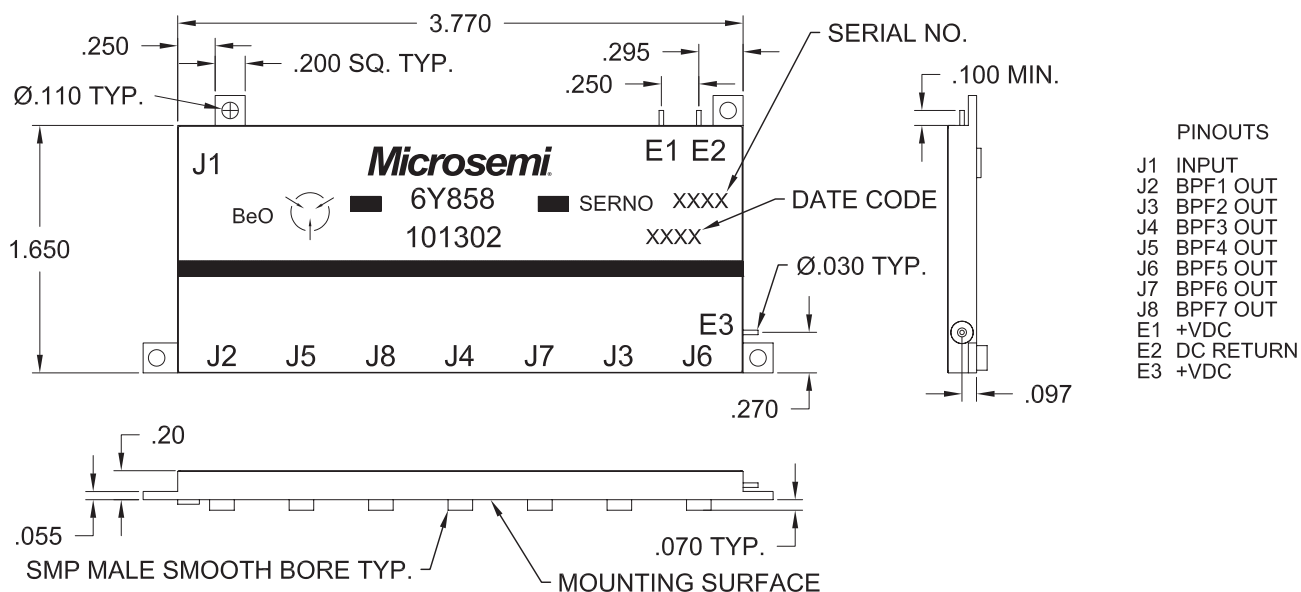

Microsemi Corporate Headquarters
 One Enterprise, Aliso Viejo, CA 92656 USA
 Within the USA: +1 (800) 713-4113
 Outside the USA: +1 (949) 380-6100
 Fax: +1 (949) 215-4996
 Email: sales.support@microsemi.com
 www.microsemi.com

©2017 Microsemi Corporation. All rights reserved. Microsemi and the Microsemi logo are registered trademarks of Microsemi Corporation. All other trademarks and service marks are the property of their respective owners.

Microsemi Corporation (Nasdaq: MSCC) offers a comprehensive portfolio of semiconductor and system solutions for aerospace & defense, communications, data center and industrial markets. Products include high-performance and radiation-hardened analog mixed-signal integrated circuits, FPGAs, SoCs and ASICs; power management products; timing and synchronization devices and precise time solutions, setting the world's standard for time; voice processing devices; RF solutions; discrete components; enterprise storage and communication solutions, security technologies and scalable anti-tamper products; Ethernet solutions; Power-over-Ethernet ICs and midspans; as well as custom design capabilities and services. Microsemi is headquartered in Aliso Viejo, California and has approximately 4,800 employees globally. Learn more at www.microsemi.com.

Microsemi makes no warranty, representation, or guarantee regarding the information contained herein or the suitability of its products and services for any particular purpose, nor does Microsemi assume any liability whatsoever arising out of the application or use of any product or circuit. The products sold hereunder and any other products sold by Microsemi have been subject to limited testing and should not be used in conjunction with mission-critical equipment or applications. Any performance specifications are believed to be reliable but are not verified, and Buyer must conduct and complete all performance and other testing of the products, alone and together with, or installed in, any end-products. Buyer shall not rely on any data and performance specifications or parameters provided by Microsemi. It is the Buyer's responsibility to independently determine suitability of any products and to test and verify the same. The information provided by Microsemi hereunder is provided "as is, where is" and with all faults, and the entire risk associated with such information is entirely with the Buyer. Microsemi does not grant, explicitly or implicitly, to any party any patent rights, licenses, or any other IP rights, whether with regard to such information itself or anything described by such information. Information provided in this document is proprietary to Microsemi, and Microsemi reserves the right to make any changes to the information in this document or to any products and services at any time without notice.