

100657C

CI60-6-3.125/12.5/50 Pulse Expansion and Compression Switched Dispersive Filter Subsystem

Specifications

Parameter	Symbol	Unit	100693	100694	100695	100696	100697	100698
Component			100693	100694	100695	100696	100697	100698
Center Frequency	F_0	MHz defined	60	60	60	60	60	60
Bandwidth	B	MHz defined	6	6	6	6	6	6
Dispersion	T	μsec defined	50	50	3.125	3.125	12.5	12.5
Delay	T_0	μsec typ	28.776	28.45	3.495	3.205	8.351	8.21
Slope	S_0	$\mu\text{s}/\text{MHz}$ typ	8.33	-8.33	0.52	-0.52	2.08	-2.08
Pulse Width at -3 dB		μsec max	0.14	0.229	0.12	0.218	0.135	0.214
Sidelobes for $ t - T_0 < T$		dB max		-33		-35		-31
Time Spurious for $ t - T_0 > T$		dB max		-60		-60		-60
Processing Gain		dB min		23		17		11
Noise Gain		dB min		-5		-5		-5
Power In for -1 dB Comp		dBm min		5		5		5
Dynamic Range		dB min		80		80		80
Return Loss		dB min	10					
DC Power	15V @ 2.5A, 5V @ 1A, Oven 24V @ 1A at 22°C, 2.5A Warmup							

Note

Switched Dispersive Filter Subsystem.

System Block Diagram

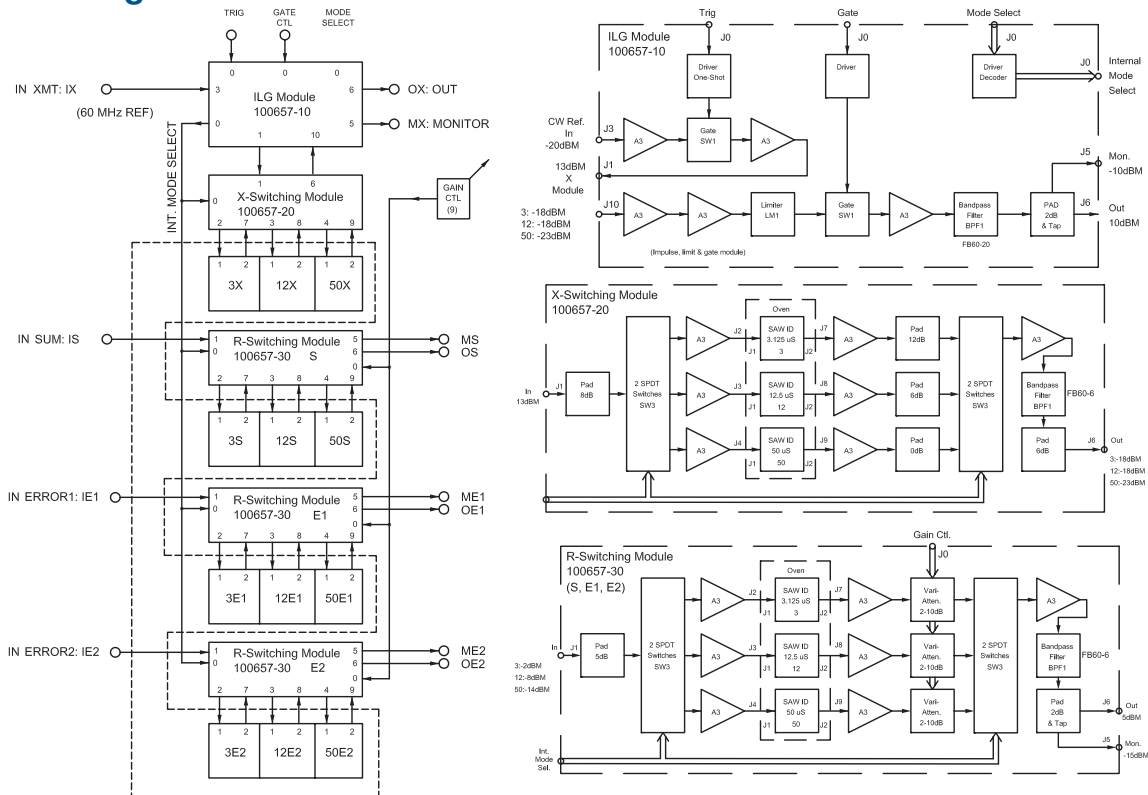

All SAWs are mounted in a Single Temperature Controlled Oven Module.

100657C

CI60-6-3.125/12.5/50 Pulse Expansion and Compression Switched Dispersive Filter Subsystem

Package Outline

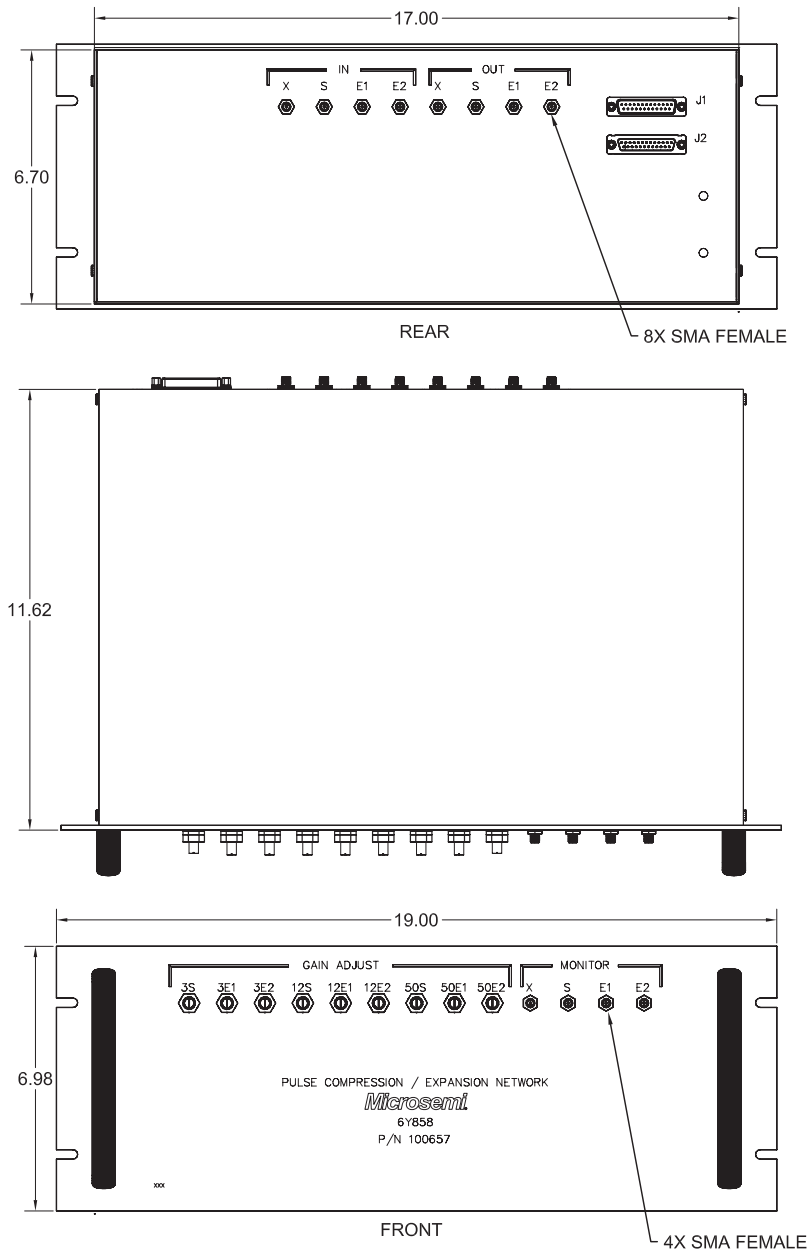

Microsemi Corporate Headquarters
 One Enterprise, Aliso Viejo, CA 92656 USA
 Within the USA: +1 (800) 713-4113
 Outside the USA: +1 (949) 380-6100
 Fax: +1 (949) 215-4996
 Email: sales.support@microsemi.com
 www.microsemi.com

Microsemi Corporation (Nasdaq: MSCC) offers a comprehensive portfolio of semiconductor and system solutions for aerospace & defense, communications, data center and industrial markets. Products include high-performance and radiation-hardened analog mixed-signal integrated circuits, FPGAs, SoCs and ASICs; power management products; timing and synchronization devices and precise time solutions, setting the world's standard for time; voice processing devices; RF solutions; discrete components; enterprise storage and communication solutions, security technologies and scalable anti-tamper products; Ethernet solutions; Power-over-Ethernet ICs and midspans; as well as custom design capabilities and services. Microsemi is headquartered in Aliso Viejo, California and has approximately 4,800 employees globally. Learn more at www.microsemi.com.

Microsemi makes no warranty, representation, or guarantee regarding the information contained herein or the suitability of its products and services for any particular purpose, nor does Microsemi assume any liability whatsoever arising out of the application or use of any product or circuit. The products sold hereunder and any other products sold by Microsemi have been subject to limited testing and should not be used in conjunction with mission-critical equipment or applications. Any performance specifications are believed to be reliable but are not verified, and Buyer must conduct and complete all performance and other testing of the products, alone and together with, or installed in, any end-products. Buyer shall not rely on any data and performance specifications or parameters provided by Microsemi. It is the Buyer's responsibility to independently determine suitability of any products and to test and verify the same. The information provided by Microsemi hereunder is provided "as is, where is" and with all faults, and the entire risk associated with such information is entirely with the Buyer. Microsemi does not grant, explicitly or implicitly, to any party any patent rights, licenses, or any other IP rights, whether with regard to such information itself or anything described by such information. Information provided in this document is proprietary to Microsemi, and Microsemi reserves the right to make any changes to the information in this document or to any products and services at any time without notice.