

PD70211

Datasheet

**PD Controller with Switching Regulator for AF/AT/UPOE
/HDBaseT/4-pair PoE Applications**

September 2019



a  **MICROCHIP** company

Contents

1	Revision History	1
1.1	Revision 2.0	1
1.2	Revision 1.4	1
1.3	Revision 1.31	1
1.4	Revision 1.3	1
1.5	Revision 1.2	1
1.6	Revision 1.1	1
1.7	Revision 1.0	1
1.8	Revision 0.6	1
1.9	Revision 0.3	1
1.10	Revision 0.2	2
1.11	Revision 0.1	2
2	Product Overview	3
2.1	Features	3
2.2	Applications	4
3	Functional Descriptions	5
4	Electrical Specifications	7
4.1	Absolute Maximum Ratings	7
4.2	Operating Ratings	8
4.3	Thermal Properties	8
4.4	Electrical Characteristics	9
4.4.1	Thermal Protection	14
4.4.2	Wall Adapter Mode	14
5	Pin Configuration	16
6	Package Specifications	21
6.1	Recommended PCB Layout	22
7	Applications Information	24
7.1	Peripheral Devices	24
7.2	Setting Switching Frequency	24
7.3	Setting Soft-Start	25
7.4	Setting Pulse-skip Mode Threshold	25
7.5	Setting UVLO/Hysteresis Thresholds	26
7.6	Setting the Voltage Divider for Output Rails	26
7.7	Selecting the Sense Resistor	27
7.8	Operation with an External DC Source	28

8 Ordering Information 32

1 Revision History

The revision history describes the changes that were implemented in the document. The changes are listed by revision, starting with the most current publication.

1.1 Revision 2.0

Revision 2.0 was published in September 2019. The following is the summary of changes.

- QFN package diagram was re-drawn.
- A typo in pin name was corrected in Applications Information section.
- The column 'note' was removed from Ordering Information table.
- The document was converted to Microsemi formatting standards.

1.2 Revision 1.4

Revision 1.4 was published in July 2017. In this revision, marking and MSL3 information were updated.

1.3 Revision 1.31

Revision 1.31 was published in July 2016. In this revision, removed 'PD' in IC marking description, removed the name of the front-end die (PD70210A) in functional block diagram, and updated revision number and date in the footer.

1.4 Revision 1.3

Revision 1.3 was published in October 2015. In this revision, fixed Vaux pin description, added UVLO_ON missing information and PD70224 was changed to PD70211 in figures 9, 10, and 11.

1.5 Revision 1.2

Revision 1.2 was published in June 2015. Updated typo in part marking definition.

1.6 Revision 1.1

Revision 1.1 was published in January 2015. In revision 1.5 of this document, PCB footprint recommendation were added.

1.7 Revision 1.0

Revision 1.0 was published in August 2014. In revision 1.0 of this document, frequency setting information was added.

1.8 Revision 0.6

Revision 0.6 was published in July 2014. In revision 0.6 of this document, flags maximum voltage was reduced and WA_EN information was added.

1.9 Revision 0.3

Revision 0.3 was published in March 2013. In revision 0.3 of this document, general updates were made.

1.10 Revision 0.2

Revision 0.2 was published in March 2012. In revision 1.1 of this document, minor edits were made to Class Values.

1.11 Revision 0.1

Revision 0.1 was published in February 2012. It was the first publication of this document.

2 Product Overview

Microsemi's PD70211 is an advanced PD Interface IC with integrated switching (PWM) regulator control for Powered Devices in PoE applications. It supports IEEE802.3af, IEEE802.3at, HDBaseT, and general 2/4-pair configurations.

The PD70211 front-end includes an advanced classification block that supports 2, 3, 4, and 6 event classification. Using the SUPP_Sx pins, it also identifies which of the four pairs of the cable actually receives power and generates appropriate flags.

The IC features an internal bleeder for discharging the input capacitor of the DC/DC converter rapidly to ensure fast re-detection and port power-up, in case of sudden removal and re-insertion of the Ethernet cable into the RJ-45. The advanced PWM current-mode section supports synchronous Flyback and Active Clamp Forward topologies, as well as Buck, Boost, and so on.

2.1 Features

The PD70211 device has the following key features.

- Supports IEEE802.3af/at, HDBaseT, and other 2-pair/4-pair configurations
- Wall adapter support (Rear Aux method)
- PD detection and programmable classification
- 2,3,4, and 6 event classification
- Integrated 0.3 Ω isolating (series-pass) FET
- Inrush current limiting
- Less than 10 μ A offset current during detection
- Advanced PWM section
- Lead-free MLPQ-36 (6 mm \times 6 mm) package

2.2 Applications

The following are the applications of the PD70211 device.

- HDBaseT up to 95 Watts
- IEEE802.3af and IEEE802at
- Power forwarding
- Indoor and outdoor PoE

Figure 1 • Typical Applications Diagram

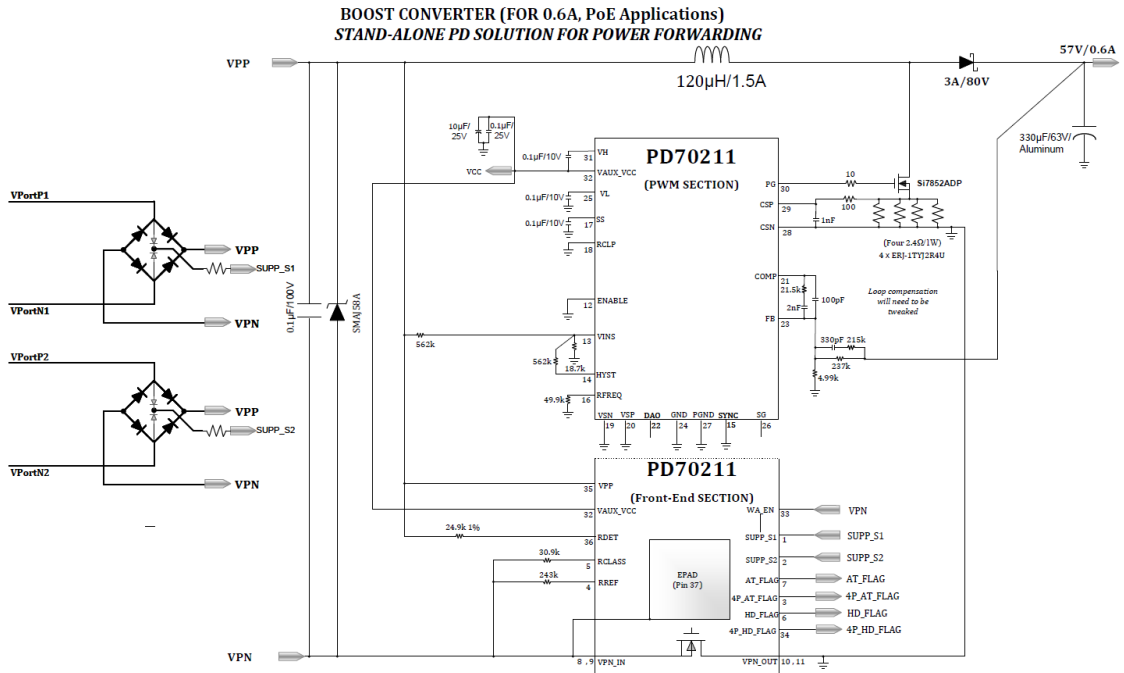

Note: Please consult Microchip Technology for the latest reference design.

3 Functional Descriptions

The following figure shows the functional blocks of the PD70211 device.

Figure 2 • PD70211 Block Diagram (Front-end Section)

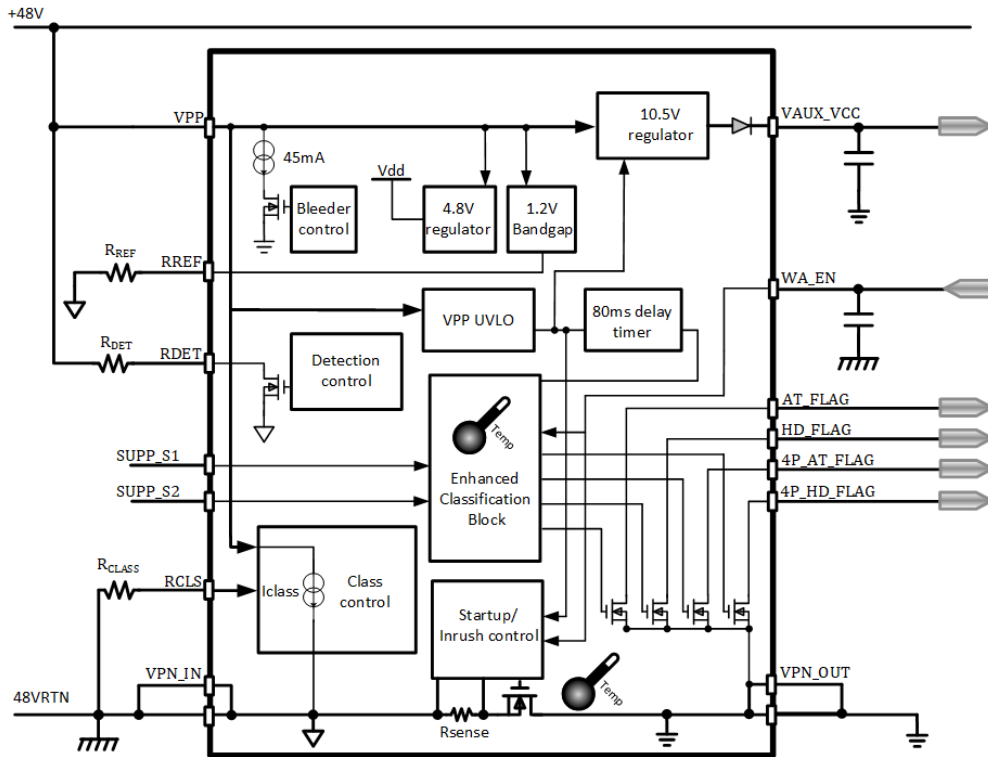
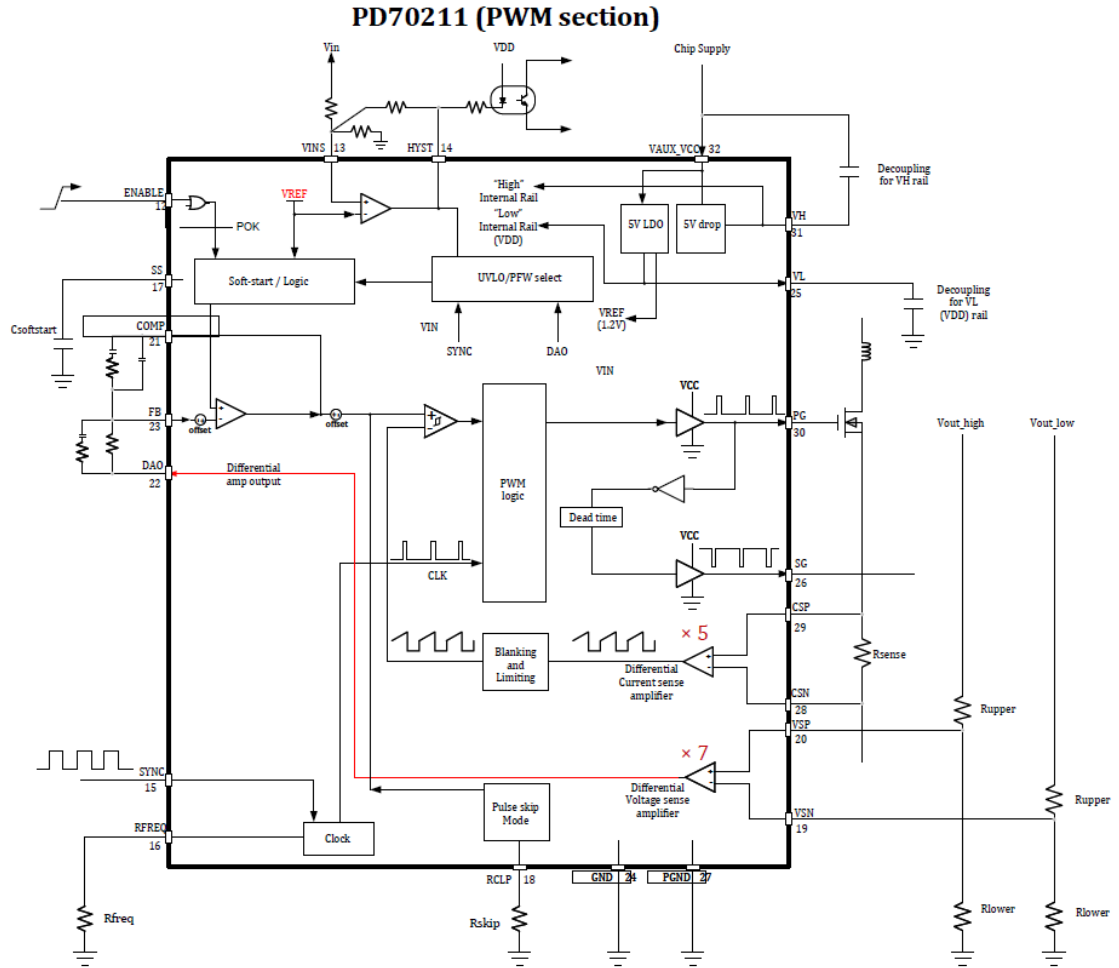

Figure 3 • PD70211 Block Diagram (PWM Section)



4 Electrical Specifications

The following section describes the electrical specifications of the PD70211 device.

4.1 Absolute Maximum Ratings

Performance is not necessarily guaranteed over this entire range. These are maximum stress ratings only. Exceeding these ratings, even momentarily, can cause immediate damage, or negatively impact long-term operating reliability. Voltages are with respect to IC ground (VPN_IN).

Table 1 • Absolute Maximum Ratings

	Min	Max	Units
VPP, VPIN_OUT, RDET	-0.3	74	V
AT_FLAG, HD_FLAG, 4P_AT_FLAG, 4P_HD_FLAG	-0.3	20	V
SUPP_S1, SUPP_S2	0	V _{VPP} + 1.5	V
RREF, RCLS, WA_EN	-0.3	5	V
VAUX_VCC	-0.3	20	V
PG, SG	-0.3	20	V
VL	-0.3	6	V
VH (with respect to VAUX_VCC)	0.3	-6	V
ENABLE			
All other pins	-0.3	VL+0.3	V
Junction temperature	-40	150	°C
Lead soldering temperature (40 s, reflow)		260	°C
Storage temperature, MSL3	-65	150	°C
ESD rating	HBM	±1.5*	kV
	MM	±50	V
	CDM	±500	V

***Note:** Pins VPP, VAUX/VCC, and RREF pass ±1 kV HBM only.

4.2 Operating Ratings

Performance is generally guaranteed over this range as detailed in the following front-end section Electrical Characteristics. Voltages are with respect to IC ground (VPN_IN).

Table 2 • Operating Ratings (Front-end Section)

Parameter	Min	Max	Units
VPP	0	57	V
Ambient temperature*	-40	85	°C
Detection range	1.1	10.1	V
Mark event range	4.9	10.1	V
Class event range	13.7	20.9	V

*The corresponding maximum operating junction temperature is 125 °C.

Performance is generally guaranteed over this range as detailed in the following PWM section Electrical Characteristics. Voltages are with respect to IC ground.

Table 3 • Operating Ratings (PWM Section)

Parameter	Min	Max	Units
VCC	7.8	20	V
Fsw (adjustable frequency range)	100	500	kHz
Maximum duty cycle		44.5	%
f _{sw_synch} (synchronization frequency range)	200	1000	kHz

4.3 Thermal Properties

The following table lists the thermal specifications for the PD70211 device.

Table 4 • Thermal Properties

Thermal Resistance	Min	Typ	Max	Units
θ _{JA}		22.3		°C/W
θ _{JP}		3		°C/W
θ _{JC}		4		°C/W

Note: The θ_{Jx} numbers assume no forced airflow. Junction temperature is calculated using $T_J = T_A + (P_D \times \theta_{JA})$. In particular, θ_{JA} is a function of the PCB construction. The stated number above is for a four-layer board in accordance with JESD-51 (JEDEC).

4.4 Electrical Characteristics

This section describes the electrical characteristics of the front-end and PWM sections, thermal protection mechanism against excessive internal temperature, and wall adapter mode functionality.

Electrical Characteristics of Front-end Section

Unless otherwise specified under conditions, the Min and Max ratings stated in the following table apply over the entire specified operating ratings of the PD70211 device. Typical values are determined either by design or by production testing at 25 °C ambient temperature. Voltages are with respect to IC ground (VPN_IN).

Table 5 • Typical Electrical Performance

Symbol	Parameter	Conditions	Min	Typ	Max	Units
Input voltage						
I _{IN}	IC input current with I _{CLASS} off	V _{PP} = 55 V		1	3	mA
Detection phase						
V _{DET}	Detection range		1.1		10.1	V
R _{DET_TH}	R _{DET} disconnect threshold		10.1		12.8	V
R _{D_S_DET_ON}	On-resistance of internal FET during detection				50	Ω
R _{D_S_DET_OFF}	Off-resistance of internal FET after detection		2			MΩ
I _{OFFSET_DET}	Input offset current	1.1 V ≤ V _{PP} ≤ 10.1 V, T _J ≤ 85 °C			5	μA
V _{R_DET_ON}	Threshold when V _{PP} goes low		2.8	3.0	4.85	V
Classification phase						
V _{CLS_ON}	Classification sink turn-on threshold		11.4		13.7	V
V _{CLS_OFF}	Classification sink turn-off threshold		20.9		23.9	V
V _{HYS_CLS_ON}	Hysteresis of V _{CLS_ON} threshold			1		V
V _{MARK_TH}	Mark detection threshold (V _{PP} falling)		10.1		11.4	V
I _{MARK}	Current sink in the mark event region		0.25		4	mA
I _{CLASS_CLIM}	Current limit of class current		50	68	80	mA
I _{CLASS}	Classification current sink	R _{CLASS} = not present (Class 0)			3	mA
		R _{CLASS} = 133 Ω (Class 1)	9.5	10.5	11.5	
		R _{CLASS} = 69.8 Ω (Class 2)	17.5	18.5	19.5	

Symbol	Parameter	Conditions	Min	Typ	Max	Units
		R _{CLASS} = 45.3 Ω (Class 3)	26.5	28.0	29.5	
		R _{CLASS} = 30.9 Ω (Class 4)	38.0	40.0	42.0	
Isolation FET						
R _{DS(on)}	On resistance	Total resistance between VPN_IN to VPN_OUT; I _{LOAD} < 600 mA, -40 °C < T _A < 85 °C			0.3	Ω
I _{CLIM_INRUSH}	Inrush current limit		105	240	325	mA
OCP	Overcurrent protection		2.2			A
I _{LOAD}	Continuous operation load				2	A
Undervoltage lockout						
UVLO _{ON}	Threshold that marks start of inrush phase		36		42	V
UVLO _{OFF}	Threshold where pass-FET turns off as VPP collapses		30.5		34.5	V
DC-DC input cap discharger						
I _{CAP_DIS}	Discharge current	7 V ≤ V _{PP} ≤ 30 V	22.8		60	mA
t _{dis}	Discharge time	C _{DC_DC} ≤ 264 μF (by design, not tested)			500	ms
timer _{dis}	Discharge timer	Time for which discharge circuit is activated	430			ms
References, rails, and logic						
V _{AUX}	Auxiliary voltage	0 mA < I _{AUX} < 4 mA	9.8	10.5	12.0	V
I _{AUX}	Maximum continuous current from V _{AUX}		4			mA
I _{AUX_CLIM}	Auxiliary current limit		10		32	mA
V _{REF}	Bandgap reference voltage		1.17	1.2	1.23	V
t _{FLAG_LO}	Low level flag	For AT_FLAG, HD_FLAG, 4P_AT_FLAG, 4P_HD_FLAG, I _{FLAG} = 3 mA			0.4	V
I _{FLAG}	Flag current driving capability	For AT_FLAG, HD_FLAG, 4P_AT_FLAG, 4P_HD_FLAG	5			mA
t _{FLAG}	Delay timer between start of inrush and flags declared	For AT_FLAG, HD_FLAG, 4P_AT_FLAG, 4P_HD_FLAG	80			ms
V _{SUPP_HI}	SUPP_Sx high voltage threshold	For SUPP_S1 and SUPP_S2	25		35	V
Wall adapter						
V _{IH}	Input high logic		2.4			V
V _{IL}	Input low logic				0.8	V

Table 6 • Truth Table for Status of Flags

Number of Fingers "N" (N-Event classification)	SUPP_S1	SUPP_S2	AT_FLAG	HD_FLAG	4P_AT_FLAG	4P_HD_FLAG
1	X	X	Hi Z	Hi Z	Hi Z	Hi Z
2	H	L	0 V	Hi Z	Hi Z	Hi Z
2	L	H	0 V	Hi Z	Hi Z	Hi Z
2	H	H	0 V	Hi Z	0 V	Hi Z
3	L	H	0 V	0 V	Hi Z	Hi Z
3	H	L	0 V	0 V	Hi Z	Hi Z
3	H	H	0 V	0 V	0 V	Hi Z
4	X	X	0 V	0 V	0 V	Hi Z
5	RESERVED FOR FUTURE					
6	X	X	0 V	0 V	0 V	0 V

Electrical Characteristics of PWM Section

Unless otherwise specified under conditions, the Min and Max ratings stated below apply over the entire specified operating ratings of the PD70211 device. Typical values stated, are determined either by design or by production testing at 25 °C ambient. Voltages are with respect to IC ground (VPN_IN).

Table 7 • Typical Electrical Performance

Symbol	Parameter	Conditions	Min	Typ	Max	Units
Input voltage current						
V _{CC_UVLO_UP}	UVLO threshold with input rising	V _{CC} rise time ≥ 0.5 ms	8.85	9.15	9.5	V
V _{CC_UVLO_DN}	UVLO threshold with input falling	V _{CC} rise time ≥ 0.5 ms	7	7.3	7.6	V
I _{VCC_SD}	IC input current (no switching)	V _{ENABLE} = Low, or V _{VCC} < V _{CC_UVLO_UP}		1	2000	μA
I _{VCC_Q}	IC input current (switching, no load on SG, PG, VDD)	V _{ENABLE} = High, and V _{VCC} > V _{CC_UVLO_UP} , f _{sw} = 500 kHz			3	mA
Input UVLO/PFW						
V _{INS_TH}	Threshold on VINS pin	Rising or falling	1.171	1.200	1.229	V
V _{HYST_HIGH}	Hysteresis pin high voltage	I _{HYST_SOURCING} = 1 mA	2.8			V
V _{HYST_LOW}	Hysteresis pin low voltage	I _{HYST_SINKING} = 3 mA			0.4	V
LDOs						
V _L		I _{VDD_EXT} < 5 mA (current out of pin)	4.75	5	5.25	V
V _H	VH rail (with respect to VCC)			-5		V
Soft start						
I _{SS_CH}	Current out of SS pin during charging phase	RFREQ = 33.3k, V _{SS} = 0.5 V	32	36	40	μA
I _{SS_DISCH}	Current into SS pin during discharging phase	RFREQ = 33.3k, V _{SS} = 0.5 V		10		% of I _{SS_CH}
V _{SS_CH}	Soft start charge completed threshold	By design only	90		95	% of VREF
V _{SS_DISCH}	Soft start discharge completed threshold			50		mV
R _{SS_DISCH}	Soft-start pin discharge FET resistance			50		Ω
t _{DISCH}	Soft-start discharge FET on-time			32		Switch cycles
Switching frequency and synchronization						

Symbol	Parameter	Conditions	Min	Typ	Max	Units
f _{sw_range}	Switching frequency accuracy	RFREQ = 33.2k	285	315	345	kHz
f _{sync_max}	Maximum synchronization frequency		1			MHz
V _{SYNC_HI}	SYNC pin high threshold		2.4			V
V _{SYNC_LO}	SYNC pin low threshold				0.8	V
t _{sync}	Minimum pulse width of SYNC pulse		100			ns
D _{sync_max}	Maximum SYNC pulse duty cycle				90	%
Error amplifier						
VREF	Reference voltage		1.171	1.200	1.229	V
Gain _{DC_OPL}	DC open-loop gain	Rload = 100k	70	100		dB
AV _{UGBW}	Unity gain bandwidth	Cload = 10 pF (By design only)	2	5		MHz
I _{COMP_OUT}	Output sourcing current	0.2 V ≤ V _{COMP} ≤ 1.3 V	110		620	μA
I _{COMP_IN}	Output sinking current	0.2 V ≤ V _{COMP} ≤ 1.3 V	145		495	μA
V _{EA_CMR_MAX}	Maximum of input common-mode range		2			V
V _{CLAMP}	COMP pin high clamp		1.8	2.1	2.6	V
PWM comparator						
V _{OFFSET}	Inserted offset in inverted input		200		300	mV
V _{RCLP}	Voltage set on RCLP pin by external resistor to GND		0		1	V
Current sense amplifier						
Gain _{CSA}	DC Gain	0 mA < I _{AUX} < 4 mA	4.75	5	5.25	V
I _{AUX}	Maximum continuous current from V _{AUX}		4			mA
V _{CSA_CMR_MAX}	Maximum input common-mode range		2			V
t _{BLANK}	Blanking time		50		100	ns
V _{LIM}	Current limit threshold on output of current sense amplifier	Where PWM pulses start to get truncated	1.1	1.2	1.3	V
V _{LIMHICCUP}	Current limit threshold on output of current sense amplifier capability	Where PWM pulses start to get omitted in hiccup mode	1.7	1.8	1.9	V
Differential voltage amplifier						
Gain _{DA}	DC gain of differential voltage amplifier		6.68	7.0	7.14	V

Symbol	Parameter	Conditions	Min	Typ	Max	Units
AV _{UGBW_DA}	Unity gain bandwidth of differential voltage amplifier			5		MHz
V _{DA_CMR_MAX}	Maximum of input common-mode range		3.5			V
Drivers						
R _{PG_HI}	Drive resistance when PG is high			10		Ω
R _{PG_LO}	Drive resistance when PG is low			5		Ω
t _{PG_MIN}	Minimum on-time of PG				120	ns
D _{MAX}	PG maximum duty cycle		44.5		50	%
R _{SG_HI}	Drive resistance when SG is high			10		
R _{SG_LO}	Drive resistance when SG is low			10		
t _{DEAD}	Deadtime		60	110	190	ns
Logic levels on VINS and ENABLE						
V _{HI}	Input high threshold		2			V
V _{LO}	Input low threshold				0.8	V
Thermal protection						
T _{SD}	Thermal shutdown (rising)			157		°C
T _{HYST}	Thermal shutdown hysteresis			15	30	°C

4.4.1 Thermal Protection

PD70211 is protected from excessive internal temperatures that may occur during various operating procedures. Two temperature sensors are located on the chip, monitoring the temperatures of the following:

- Isolating Switch (pass-FET)
- Classification Current Sink

Each of the over temperature sensor activates a protection mechanism that will disconnect the Isolation (pass) FET or the classification circuit, respectively. This protects the device from being permanently damaged or even from long-term degradation.

4.4.2 Wall Adapter Mode

PD70211 supports wall adapter functionality. That is, by setting WA_EN pin high, it will give priority to the wall adapter jack to supply the load.

WA_EN pin is used while connecting a wall adapter voltage between VPP and VP_{N_OUT} by means of an OR-ing diode.

While WA_EN, wall adapter enable pin, is held low (referenced to VPN_IN), the front-end works as a normal PD.

When WA_EN is raised high (referenced to VPN_IN), three internal operations are forced:

- The Isolation FET is turned OFF.
- All output flags AT_FLAG, HD_FLAG, 4P_AT_FLAG, and 4P_HD_FLAG are activated (low state).
- Vaux output voltage is turned ON.

While activating WA_EN pin, the wall adapter will supply input voltage for the DC-DC converter.

Having WA_EN at high state does not disable detection and classification modes.

5 Pin Configuration

The following illustration shows the device pin diagram from the top view.

Figure 4 • PD70211 Pinout

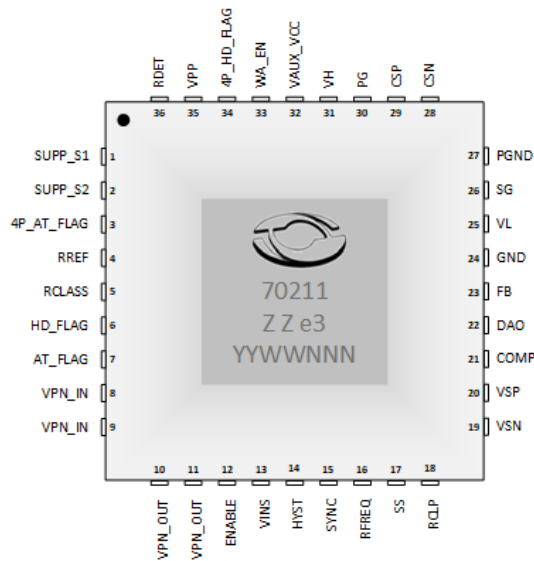

(Top view)

The following table lists the pin descriptions of the PD70211 device.

Table 8 • Pin Descriptions

Pin Number	Designator	Description
1	SUPP_S1	Input pin for sensing the voltage on the diode bridge connected to the data pairs. This pin along with the SUPP_S2 pin can be used to distinguish between 2-pair and 4-pair operation. (For PSEs that operate in 4 pairs but generates the classification procedure on only one pair and not on both pairs). Signal is referenced to VPN_IN. Place a 10k resistor in the input of this pin.
2	SUPP_S2	Input pin for sensing the voltage on the diode bridge connected to the data pairs. This pin along with the SUPP_S1 pin can be used to distinguish between 2-pair and 4-pair operation. (For PSEs that operate in 4 pairs but generates the classification procedure on only one pair and not on both pairs). Signal is referenced to VPN_IN. Place a 10k resistor in the input of this pin.
3	4P_AT_FLAG	Open Drain Output. The pin gets actively pulled low when a 4-pair version of a (non-standard) Type 2 PD-PSE mutually identify each other via classification. There is a minimum 80 ms delay from the moment when the input capacitor is fully charged to this signal activity. Signal is referenced to VPN_OUT.
4	RREF	Bias current resistor. A 60.4k, 1% resistor is connected between RREF and IC ground (VPN_IN).

Pin Number	Designator	Description
5	RCLASS	Sets the Class of the PD. Connect RCLASS (programming resistor) between this pin and IC ground (VPN_IN). Allowed values are 133 Ω, 69.8 Ω, 45.3 Ω, and 30.9 Ω for Class 1, 2, 3, and 4 respectively. If RCLASS is not present, the PD will draw up to 3 mA during classification, thus indicating Class 0 (default Type 1) to the PSE. Signal is referenced to VPN_IN.
6	HD_FLAG	Open Drain Output. The pin gets actively pulled low when a 2-pair HDBaseT PD-PSE mutually identify each other via classification. There is a minimum 80 ms delay from the moment when the input capacitor is fully charged to this signal activity. Signal is referenced to VPN_OUT.
7	AT_FLAG	Open Drain Output. This pin gets actively pulled low when a Type 2 PD-PSE mutually identifies each other via classification. There is a minimum 80 ms delay from the moment when the input capacitor is fully charged to this signal activity. Signal is referenced to VPN_OUT.
8, 9	VPN_IN	Lower rail of the incoming PSE voltage rail – from the negative terminal of the two OR-ed bridge rectifiers (the corresponding upper PoE rail is VPP).
10, 11	VPN_OUT	This is in effect, the switched ground for establishing continuity to the PWM section after successful detection, classification, and power-up. It is connected to the power ground and PWM controller IC's ground plane of the DC-DC converter section.
12	ENABLE	A logic-level input to enable the converter. We can pull it constantly up, say with a 100k resistor to VDD, to forcibly enable the converter, provided the input supply has exceeded any applicable UVLO thresholds as set on the VINS pin or on the VCC pin. Internally, the ENABLE pin goes to the input of an OR-gate, the other input terminal of which is tied to "POK" – a signal provided by the front-end. If the ENABLE pin is forced high, the output of the OR-gate goes high and the converter is allowed to start (provided all UVLO's are past). If the ENABLE pin is held low, the internal node "POK" goes active/high when the PD's front end conducts (power OK), so the OR-gate goes high once again. In this case, the switching converter turns ON as required by the PoE standard. However, for supporting wall adapters, injecting power after the front-end (at the input of the converter), we can forcefully turn the converter ON without the front-end signaling "PGOOD", by not tying the ENABLE pin low, but by tying it high (to VDD). That will turn ON the converter irrespective of the state of the front-end (conducting or not), and whether there is any incoming PoE power or not.
13	VINS	The VINS pin is a programmable UVLO pin. The converter will turn ON provided the voltage on the VINS pin is above 1.2 V (and VCC is not in UVLO, and ENABLE pin is also high – connected to VDD, for example). The converter will stop switching (turns OFF) when the voltage on the VINS pin falls below 1.2 V (or if ENABLE is taken low, or if VCC falls outside its operating range). Thus, by connecting a voltage divider between input rail and IC ground, we can set the UVLO threshold to enable switching. However, to have a smooth startup, it is advisable to have some hysteresis too, by means of a resistor between VINS and HYST as explained below.

Pin Number	Designator	Description
14	HYST	This is the output of the UVLO comparator as shown in the Block Diagram. We connect a “hysteresis resistor” from HYST pin to VINS pin to create positive feedback (and hysteresis). Initially, as the input voltage is rising, the VINS pin voltage is below 1.2 V and so the output of the UVLO comparator is low, leading the hysteresis resistor to fall in parallel to the lower resistor of the UVLO divider placed at the VINS pin, assisting it to pull down the VINS pin voltage further. As soon as the rising UVLO threshold is exceeded (VINS > 1.2 V), the output of the UVLO comparator suddenly goes high (up to VDD) and the hysteresis resistor, effectively comes partially across the upper resistor of the UVLO divider, assisting it in to pull up the voltage on the VINS pin. This feedback therefore increases the voltage on the VINS pin. Now, the input rail has to fall to a much lower level to allow the VINS pin voltage to fall below 1.2 V. That is how hysteresis is created by positive feedback action through the hysteresis resistor. The exact math is in the applications information of this datasheet. Note that HYST pin always toggles between high or low depending on whether the voltage on the VINS pin is above or below 1.2 V, respectively. This can always be used to simultaneously drive an opto, to indicate when the input rail is above the programmed rising threshold and when it falls below the programmed falling threshold.
15	SYNC	Used to synchronize the LX7309 to a frequency higher than its default value as set on RFREQ pin. The synchronizing clock must be 2x the desired sync frequency, with a maximum synchronizing clock frequency of 1 MHz (for 500 kHz PWM frequency). The PG pin’s rising edge will occur at the same instant as the rising edge of the clock being applied on the SYNC pin.
16	RFREQ	Connect a programming resistor from this pin to IC ground (pin GND) to set the switching frequency. A typical value of the programming resistor is 49.9k, and this value will provide a frequency of 215 kHz. Halving it will roughly double the frequency, whereas doubling it will halve the frequency. Note that the converter is designed to operate from 100 to 500 kHz based on this pin. Switching Frequency Equation: $Freq = \frac{1}{(90pF \times RFREQ) + 150ns}$ where Freq is [Hz] and R _{FREQ} in [Ω] For further information, see Setting Switching Frequency.
17	SS	This is the soft-start pin. Typically, a 0.1 μF capacitor, the “soft-start capacitor”, is connected between this pin and IC ground (pin GND). The capacitor gets charged up to 1.2 V by an internal resistor, and the voltage on the capacitor, in effect, forms the input voltage reference VREF of the error amplifier. But, note that this capacitor serves other functions too; for example, it controls the rate of hiccupping under overcurrent fault conditions. So, even if the internal reference is not being used (as in isolated topologies with a TL431 on the secondary side), the soft-stat capacitor is recommended to be in place always. The actual capacitor used will be determined by the application. For further information, see Setting Soft-Start.
18	RCLP	Low power clamp resistor. We can connect a resistor from this pin to IC ground (pin GND) to set the exact level at which pulse-skipping mode is entered at light loads. However, the usual default is to connect this pin directly to IC ground, in which case pulse-skipping mode is disabled. The method to select the threshold (and RCLP resistor value) is described in the Applications Information section of this datasheet.

Pin Number	Designator	Description
19	VSN	The negative input of the internal differential-sense voltage amplifier. Note that the common-mode range of the differential voltage amplifier is 3.5 V and its gain is 7. We can use this differential amplifier for implementing topologies where the “system (output) ground” is different from the IC ground. We can then step-down both output rails (output rail and its return), by equal amounts, using identical voltage dividers, to bring the voltage below 3.5 V, then use differential sensing, and finally connect the output of the differential voltage amplifier (pin DAO) to FB pin.
20	VSP	The positive input of the internal differential-sense voltage amplifier. Note that it must always be connected in such a way that VSP is at a higher voltage than VSN. Also keep in mind that since the differential voltage amplifier has a gain of 7 and the output of that amplifier is connected to the feedback pin which compares that against a 1.2 V reference, in effect, the difference between VSP and VSN stabilizes to $1.2\text{V}/7 = 0.171\text{ V}$ in steady state. That is how the (identical) voltage dividers present on VSP and VSN are designed.
21	COMP	This is the output of the internal error amplifier, and the input of the PWM comparator. It is brought out to support isolated topologies because in such cases, there is an error amplifier already present on the secondary side (for example a TL431 or equivalent). Therefore, we want to bypass the error amplifier of the converter section. On the other hand, in non-isolated topologies, we want to use the error amplifier of the converter. We can do that directly or through the differential voltage amplifier stage.
22	DAO	This is the output of the internal differential voltage amplifier (gain = 7). When this amplifier is used, we connect DAO to the feedback pin (FB). We have part of the compensation network between the two pins, and this network is typical of any Type 3 error amplifier input, with or without a differential amplifier.
23	FB	This is the feedback pin of the IC. It is internally compared to a 1.2 V reference. If the internal error amplifier is not used and the COMP pin is being used to inject the error signal (as in isolated topologies), the FB pin can be either tied high (to VDD), or connected to COMP.
24	GND	This is the IC ground or the analog (quiet) ground of the IC. Pin 20 is the Power ground (PGND). Typically, we can connect the analog ground and PGND together on a copper island on the component side, and then connect that through several vias very close to the chip on to a large ground plane which extends up to the lower side of the current sense resistor. All chip decoupling can then be very simple with respect to the copper island on the component side.
25	VL	This is created by an internal LDO and basically provides a housekeeping rail for the IC itself, which is 5 V with respect to the IC ground. A 1 μF ceramic cap placed close to this pin, connected to IC ground is recommended for proper decoupling. This pin can also provide up to 5 mA for external circuitry if required, thermal aspects (IC dissipation) being considered.
26	SG	Secondary Gate driver. We can use this to drive a synchronous FET or an active clamp FET. It is derived from VCC ($\sim 12\text{ V}$), and has a 10 Ω limiting resistor. So, it can be used to drive a Gate-drive transformer directly. It is usually complementary to the Primary Gate driver pin (PG). But there is a typical 110 ns blanking time between the two to prevent cross-conduction. SG is held firmly low in pulse-skip mode (if allowed). It is also low during soft-start. It allows forced PWM (continuous conduction) mode by allowing negative inductor currents. It does not support diode-emulation mode (discontinuous conduction mode). However, in pulse-skip mode, since SG stays OFF, the converter automatically lapses into discontinuous conduction mode through the body-diode of the synchronous FET. We can leave this pin floating if unused.

Pin Number	Designator	Description
27	PGND	Power ground (for internal SG and PG drivers). This is ideal for VCC decoupling and the Primary-side current sense resistor's lower terminal. We can also combine GND and PGND on to a single large ground plane. Note that Power ground plane is firmly connected to VPN_OUT, which is the drain side of the PD's low-side pass-FET (it stands for Negative Port Voltage Out).
28	CSN	The negative input of the internal current-sense voltage amplifier. Note that the common-mode range of the differential current-sense amplifier is 2 V and its gain is 5. We can use this for high-side current sensing up to 2 V. It is then placed on the (steady) output side of a Buck inductor, and the maximum output voltage is 1.8 V for using this type of sensing. Ensure that CSN is at a lower voltage compared to the positive input of the current-sense amplifier (CSP). Current sensing can also be implemented in a more basic fashion for "low-side" sensing, with a resistor in the return (ground) of the Buck. In that case, CSN is shown connected to IC ground. However, to avoid noise from ground bounce, it is best to route this on the PCB in Kelvin manner to the lower end of the sense resistor. This is important because the peak operating voltage on the sense resistor is only 200 mV and PCB-related noise can cause jitter in the switching waveform in current-mode control.
29	CSP	The positive input of the internal current-sense voltage amplifier. See description of Pin 28 (CSN) above. Note that the output of the current-sense amplifier is amplified 5 times. So a 0.2 V current-sense voltage translates to a 1 V swing at the input of the PWM comparator. Higher voltages lead to hiccup mode protection.
30	PG	This stands for Primary Gate driver. We can use this to drive the main FET, and it has a 5 or 10 Ω limiting drive resistor switched between a voltage close to VCC rail and the IC ground. For guaranteeing proper shutdown during OFF time, it is necessary to add a 470k resistor from PG to VINS, as shown in figure 1 (see page 4).
31	VH	Internal rail of -5 V with respect to VCC, brought out only for decoupling purposes. Connect a 0.1 μ F ceramic cap very close, from this pin to VAUX_VCC pin.
32	VAUX_VCC	Auxiliary voltage rail from front-end to the VCC (supply) input of the PWM section. The front-end provides a few mA of startup current for the PWM controller (at typically 10.5 V). Signal is referenced to VPN_OUT and is activated once front-end power up sequence ends. After initial startup of PWM section, a bias winding can be connected to this pin through a diode, to sustain the PWM section.
33	WA_EN	While this input is low (referenced to VPN_IN) the chip works according to internal flow diagram. When this input is high, it enables wall adapter feature. Place 100 nF/10 V capacitor from WA_EN to VPN_IN pins, locate it close to device. When WA_EN is not used, connect it to VPN_IN. For further information, see external source connected to PD device output.
34	4P_HD_FLAG	Open Drain Output. The pin gets actively pulled low when a 4-pair HDBaseT PD-PSE mutually identify each other via classification. There is a minimum 80 ms delay from the moment that the input capacitor is fully charged to this signal activity. Signal is referenced to VPN_OUT.
35	VPP	Upper rail of the incoming PSE voltage rail – from the positive terminal of the two OR-ed bridge rectifiers (the corresponding lower PoE rail is VPN_IN).
36	RDET	Internally connects to VPN_IN during detection phase and disengages after it is over. A 25 k Ω (or 24.9K), 1% resistor is connected between this pin and VPP.
37	EPAD	Connected on PCB plane to VPN_IN.

6 Package Specifications

The following section describes the package information of the PD70211 device.

The PD70211 package is a 6 mm × 6 mm, 36-pin QFN, as shown in the following illustration.

Figure 5 • QFN Package

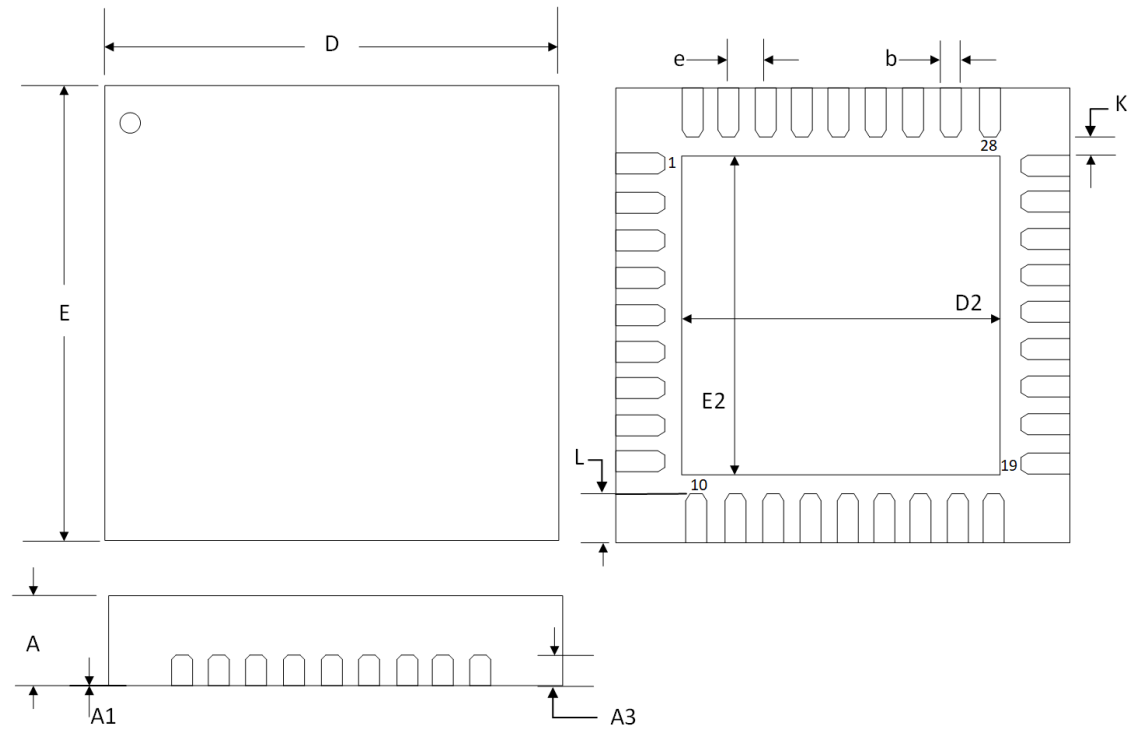

Note:

1. Dimensions do not include protrusions; these shall not exceed 0.155 mm (0.006") on any side. Lead dimension shall not include solder coverage.
2. Dimensions are in millimeters. Inches are for reference only.

The following table lists the dimensions for the QFN package.

Table 9 • Package Dimensions

Dimension	Millimeters		Inches	
	Min	Max	Min	Max
A	0.80	1.00	0.031	0.039
A1	0.00	0.05	0	0.002
A3	0.20 REF		0.008 REF	
e	0.50 BSC		0.019 BSC	
L	0.45	0.65	0.018	0.026
b	0.18	0.30	0.007	0.011

Dimension	Millimeters		Inches	
D2	4.00	4.25	0.157	0.167
E2	4.00	4.25	0.157	0.167
D	6.00 BSC		0.236 BSC	
E	6.00 BSC		0.236 BSC	

6.1 Recommended PCB Layout

The recommended PCB layout pattern for PD70211 is shown in the following figures.

Figure 6 • PD70211 Top Layer Copper Recommended PCB Layout (mm)

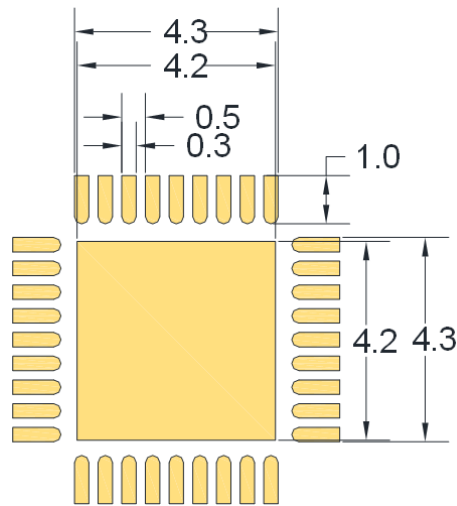

Figure 7 • PD70211 Top Layer Solder Mask, Solder Paste and Vias Recommended PCB Layout (mm)

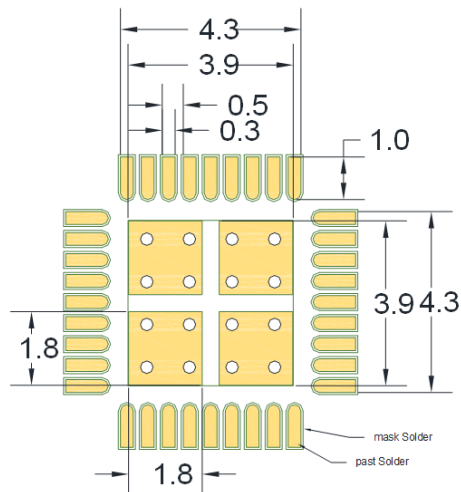
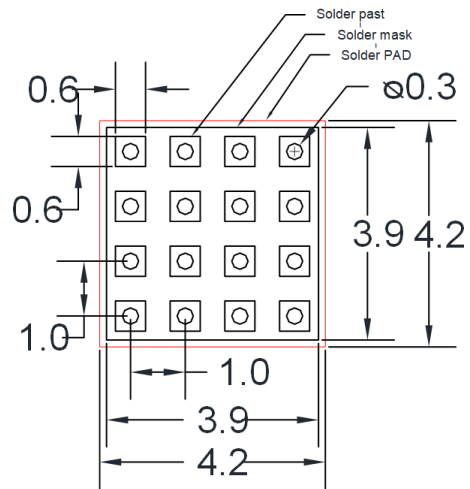

Figure 8 • PD70211 Bottom Layer Copper and Solder Paste Recommended PCB Layout for Thermal Pad Array (mm)



7 Applications Information

PD70211 application is described in the following sections.

7.1 Peripheral Devices

- An 100 nF/100 V capacitor should be placed between device VPP and VPN_IN pins, and located as close as possible to the device.
- An 58 V TVS should be placed between device VPP and VPN_IN pins.
- An 10K ohm resistor should be placed on SUPP_S1 and SUPP_S2 lines between diode bridge and PD70211 device.
- When WA_EN is used, a 1 μ F/10 V or 100 nF/10 V capacitor should be placed between WA_EN and VPN_IN pins close to PD70211 device. Please consult Microchip Technology for optimized recommendation.
- When not used, WA_EN should be connected to VPN_IN pin.

7.2 Setting Switching Frequency

A resistor, RFREQ, is connected from RFREQ pin to IC ground. Based on that, we get the following frequency.

$$Freq = \frac{1}{(90pF \times R_{FREQ}) + 150ns}$$

where Freq is [Hz] and Rfreq in Ω .

For example, by setting RFREQ=49900 Ω , we get

$$Freq = \frac{1}{(90pF \times 49900\Omega) + 150ns} = \sim 215000Hz$$

We can set any frequency between 100 kHz to 500 kHz. Note that when synchronizing, the default frequency (as set by RFREQ) must be lower than the synchronization clock. In case the synchronization breaks, the converter will lapse back to the default value. When synchronizing, we can increase the frequency to 1 MHz.

7.3 Setting Soft-Start

A capacitor is connected between SS pin and IC ground. The current charging the capacitor is

$$I_{SS_CHG} = \frac{1.2V}{RFREQ} \text{ (in seconds)}$$

For example, if RFREQ = 49.9k, we get

$$I_{SS_CHG} = \frac{1.2V}{49.9 \times 10^3} \text{ (in Amperes)} = 2.4 \times 10^{-5} \Rightarrow 24\mu A$$

So, charging a 0.1 μF ceramic cap on the soft-start pin from 0 V to 1.2 V will take

$$t_{SS} = \frac{C \times \Delta V}{I_{SS_CHG}} \text{ (in seconds)} = \frac{0.1\mu \times 1.2}{24\mu} \text{ (in seconds)} = \frac{0.12}{24} \text{ (in seconds)} = 5 \times 10^{-3} \text{ (in seconds)} \Rightarrow 5ms$$

This is the soft-start time in this case.

7.4 Setting Pulse-skip Mode Threshold

If a programming resistor RCLP is placed between RCLP pin and IC ground, the clamping voltage level is given by

$$V_{CLP} = \frac{0.3 \times RCLP}{RFREQ} \text{ (in Volts)}$$

For example, if RCLP = RFREQ, say both are 49.9k, then the converter will enter pulse skipping when the output of the current sense amplifier drops to 0.3 V. Note that the gain with this current amplifier is 5, so in terms of the voltage on the sense resistor (input of the current amplifier), we get 0.3 V/5 = 0.06 V. Since we usually design the converter so that its peak is around 0.2 V (the peak of Rsense voltage before it starts to current limit), we are getting a ratio of 0.06 V/0.2 V = 0.3. In other words, the converter will enter pulse-skipping when the output current is 30% of the maximum designed output current.

7.5 Setting UVLO/Hysteresis Thresholds

Note: A 470k resistor from PG pin to VINS pin is required for guaranteeing proper termination of Gate drive pulse during UVLO.

Suppose we have a divider connected to input at the VINS pin. Suppose we call the resistors R_{UPPER} and R_{LOWER} . We also have a hysteresis resistor, R_{HYST} , from the output of the UVLO comparator, which provides positive feedback on to the VINS pin, as explained in the Pin Description section. So, when the input voltage is rising, in effect the hysteresis resistor is in parallel to the lower resistor R_{LOWER} . When the voltage on the VINS pin rises above 1.2 V, the UVLO comparator flips and the hysteresis resistor appears connected to 5 V (output of the UVLO comparator). The equivalent configurations are shown in [figure 9](#) (see page 26). After solving the equations, the following example indicates the set thresholds. The values are as used in [figure 3](#) (see page 6).

$$R_{UPPER} = 270k; R_{LOWER} = 8.66k; R_{HYST} = 270k$$

Part 1: (VINS less than 1.2V)

Equivalent lower resistor is a parallel combination of R_{LOWER} and R_{HYST}

$$R_{LOWER_EQUIV} = \frac{R_{LOWER} \times R_{HYST}}{R_{LOWER} + R_{HYST}} = \frac{8.66k \times 270k}{8.66k + 270k} = 8.391k$$

The rising voltage threshold is

$$V_{UVLO_UP} = VREF \times \frac{R_{UPPER} + R_{LOWER_EQUIV}}{R_{LOWER_EQUIV}} = 1.2V \times \frac{270k + 8.391k}{8.391k} = 39.8V$$

Part 2: (VINS greater than 1.2V)

$$V_{UVLO_DN} = VREF \times \frac{R_{UPPER}}{R_{LOWER}} - (VDD - VREF) \times \frac{R_{UPPER}}{R_{HYST}} + VREF$$

$$1.2V \times \frac{270k}{8.66k} - (3.8V) \times \frac{270k}{270k} + 1.2 = 34.8V$$

So with the selected resistors, we get a rising threshold of 39.8 V, and a falling threshold of 34.8 V.

Figure 9 • Equivalent Diagrams for UVLO and Hysteresis

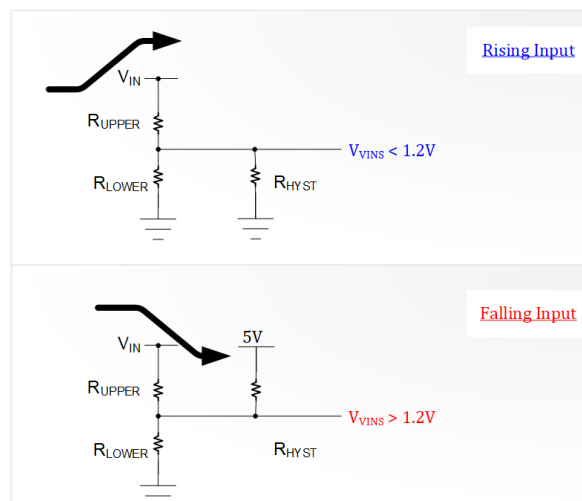

7.6 Setting the Voltage Divider for Output Rails

Generically, we can state the equation to be

$$V_{OUT} = V_X \times \frac{R_{UP} + R_{LOW}}{R_{LOW}}$$

Where R_{UP} is the name we have given to the upper resistor (connected to output rail) and R_{LOW} is the name we have given here to the resistor connected to lower rail (usually IC ground). However, there are so many topologies, we have in effect three cases in all the typical schematics presented so far.

1. Non-isolated topologies with simple divider connected directly to FB pin. For this, use $V_X = 1.2$ V.
2. Isolated topologies with divider to another reference (such as TL431 with an internal reference of 2.5 V). For this, use $V_X = 2.5$ V.
3. Non-isolated topologies with a differential divider connected to differential voltage amplifier of the LX7309. The same divider equation provided above is used, but using $V_X = 0.171$ V (that is, 1.2 V divided by the gain of the differential amplifier 7). We need two identical dividers.

7.7 Selecting the Sense Resistor

In a Buck topology, the center of the switch current ramp equals the output current. To that we need to add about 30% for the peak current “ I_{PEAK+} ” because of the rising ramp caused by the inductor. That is a factor of 1.3. We also need to include some headroom for proper transient response at maximum load. Since the peak voltage on the sense resistor is 0.2 V, to leave headroom, we should plan such that the switch current peak stays at around 0.18 V at the most, at maximum load. This means:

$$R_{SENSE} = \frac{0.138}{5A} = 0.028 \Omega$$

We may need to put an adjust resistor in parallel (such as the “22 Ω ” placeholder) we have shown in all the typical application schematics.

For a Forward converter (Buck with a transformer), instead of the load current I_{OR} in the above equation, use the reflected load current of I_o/n , where n is the turns ratio (number of Primary-side turns divided by number of Secondary-side turns). You will also need to lower the sense resistance further (by means of the adjust resistor), to account for the magnetization current component on the switch side. So roughly:

$$R_{SENSE} \approx \frac{0.138}{I_o} \times \frac{N_p}{N_s} \quad (\text{Forward})$$

For a Boost or Buck-Boost, we have to account for the fact that the peak current is not just 1.3 times maximum load current, but is actually

$$I_{\text{PEAK}} = 1.3 \times \frac{I_0}{1-D} \text{ (where D can be as high as 44\%)}$$

So, we should use the following equation for sense resistor.

$$R_{\text{SENSE}} = \frac{0.18 \times (1-D)}{1.3 \times I_0} = \frac{0.101}{1.3 \times I_0} = \frac{1}{13 \times I_0}$$

$$R_{\text{SENSE}} = \frac{0.077}{I_0} \text{ (Boost, Buck-Boost)}$$

For example, if the maximum load current is 5 A, the sense resistor value to use is

$$R_{\text{SENSE}} = \frac{0.077}{5\text{A}} = 0.015 \Omega$$

As we can see, this is roughly half of what we got for the Buck (same load current).

For a Flyback topology (Buck-Boost with a transformer), we have to use the reflected output current. So we get:

$$R_{\text{SENSE}} \approx \frac{0.077}{I_0} \times \frac{N_P}{N_S} \text{ (Flyback)}$$

7.8 Operation with an External DC Source

PD applications utilizing PD70211 IC may be operated with an external power source (DC wall adaptor). There are two cases of providing power with an external source, the cases are presented in [figure 10 \(see page 29\)](#) and [figure 11 \(see page 29\)](#).

- External source connected to application's low voltage supply rails. External source voltage level is dependent on DCDC output characteristics. See [figure 10 \(see page 29\)](#).
- External source connected to PD device output connection toward the application (VPP to VPN_{OUT}). External source voltage level is dependent on DCDC input requirements. See [figure 11 \(see page 29\)](#).

Figure 10 • External Power Input Connected to Application Supply Rails

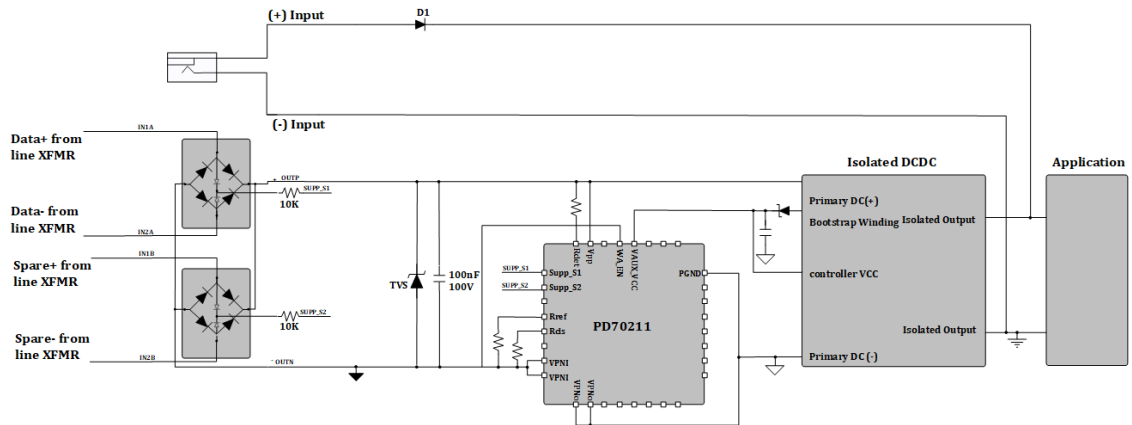
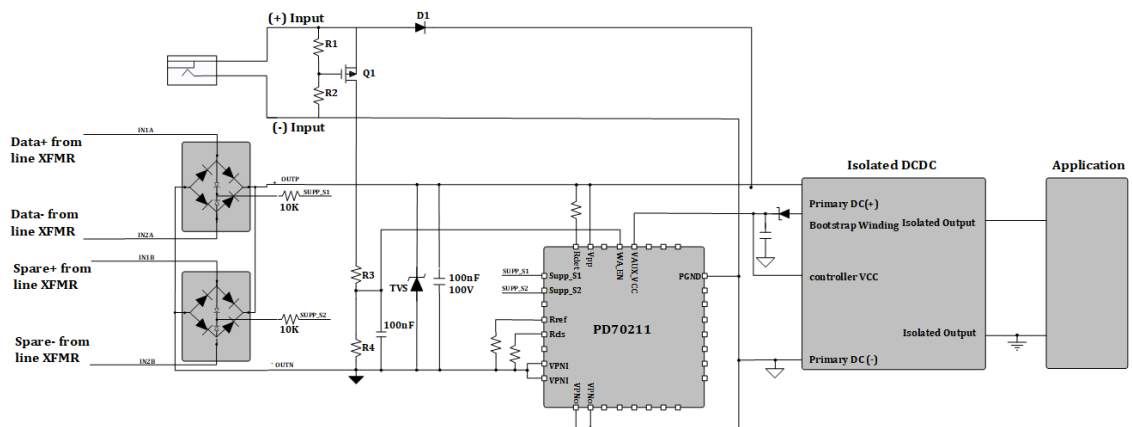

Figure 11 • External Power Input Connected to PD70211 Output



PD70211 WA_EN pin is used for disabling the isolation switch and thus PSE input power, when an external adapter is connected.

WA_EN resistors divider depends on the VinH threshold of the PD70211.

The following figure focuses on the resistors to be selected in external adapter connection.

Figure 12 • External Power Input Resistors Dividers

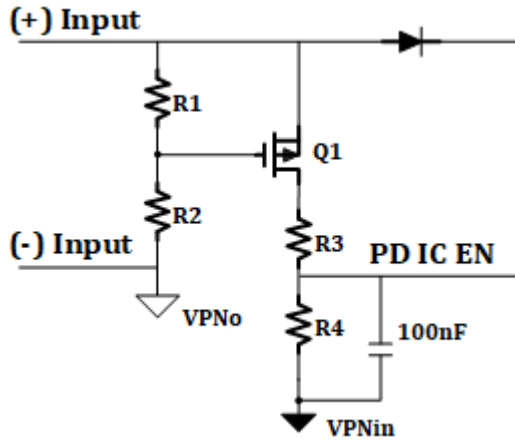

R1 and R2 set a rough threshold for Pfet Q1 enable, to detect whether the external adapter exists or not. It should be set at a lower threshold than the PD70211 disable levels.

R3 and R4 set the PD70211 disable threshold.

So, in case of 36 V – 57 V external adapter, the disable setting can be selected as follows:

Pfet enable threshold = 30 V.

R1 and R2 setting should be such that the value of Q1 VGS is less than 20 V at maximum voltage condition of the external adapter.

While external adapter voltage is above 30 V, Q1 will be above its $V_{GS_{th}}$ value.

$$V_{GS} = V_{ext_adapter} \times \frac{R1}{R1 + R2}$$

R1 is selected as 2k Ω .

$$R2 = R1 \times \frac{V_{ext_adapter} - V_{GS}}{V_{GS}}$$

Using R1 = 2k Ω , $V_{ext_adapter}$ = 30 V and V_{GS} = maximum $V_{GS_{th}}$ = 3.5 V, we get R2 value.

$$R2 = 15k\Omega$$

R3 and R4 are set to the range of few k Ω , 10's of k Ω , using the following equation.

$$(I) \quad PD70211_Wa_en = Vext_adapter_PD70211 \times \frac{R4}{(R3+R4)}$$

Using R3 = 15k Ω , Vext_adapter = 33.7 V and from data sheet we use PD70211_WA_EN=2.4 V as turn Off minimum threshold.

Solving the equation, we get the valid resistors values for an adapter of 36 V and above.

$$R3 = 15k\Omega$$

$$R4 = 1.15k\Omega$$

8 Ordering Information

The following table lists the ordering information of the PD70211 device.

Table 10 • Ordering Information

Ambient Temperature	Type	Part Marking	Ordering P/N	Package
-40 °C to 85 °C	RoHS compliant, Pb-free	MSCC Logo	PD70211ILQ-TR	MLPQ-36 (6 mm × 6 mm, 0.5 mm pitch)
		70211		
		ZZ e3 ¹		
		YYWWNNN ²		

1. ZZ e3: ZZ = Random character with no meaning and e3 = 2nd level interconnect.
2. YY = Year, WW = Week, NNN = Trace Code.



Microsemi Headquarters

One Enterprise, Aliso Viejo,
CA 92656 USA

Within the USA: +1 (800) 713-4113

Outside the USA: +1 (949) 380-6100

Sales: +1 (949) 380-6136

Fax: +1 (949) 215-4996

Email: sales.support@microsemi.com

www.microsemi.com

© 2019 Microsemi. All rights reserved. Microsemi and the Microsemi logo are trademarks of Microsemi Corporation. All other trademarks and service marks are the property of their respective owners.

Microsemi makes no warranty, representation, or guarantee regarding the information contained herein or the suitability of its products and services for any particular purpose, nor does Microsemi assume any liability whatsoever arising out of the application or use of any product or circuit. The products sold hereunder and any other products sold by Microsemi have been subject to limited testing and should not be used in conjunction with mission-critical equipment or applications. Any performance specifications are believed to be reliable but are not verified, and Buyer must conduct and complete all performance and other testing of the products, alone and together with, or installed in, any end-products. Buyer shall not rely on any data and performance specifications or parameters provided by Microsemi. It is the Buyer's responsibility to independently determine suitability of any products and to test and verify the same. The information provided by Microsemi hereunder is provided "as is, where is" and with all faults, and the entire risk associated with such information is entirely with the Buyer. Microsemi does not grant, explicitly or implicitly, to any party any patent rights, licenses, or any other IP rights, whether with regard to such information itself or anything described by such information. Information provided in this document is proprietary to Microsemi, and Microsemi reserves the right to make any changes to the information in this document or to any products and services at any time without notice.

Microsemi, a wholly owned subsidiary of Microchip Technology Inc. (Nasdaq: MCHP), offers a comprehensive portfolio of semiconductor and system solutions for aerospace & defense, communications, data center and industrial markets. Products include high-performance and radiation-hardened analog mixed-signal integrated circuits, FPGAs, SoCs and ASICs; power management products; timing and synchronization devices and precise time solutions; setting the world's standard for time; voice processing devices; RF solutions; discrete components; enterprise storage and communication solutions; security technologies and scalable anti-tamper products; Ethernet solutions; Power-over-Ethernet ICs and midspans; as well as custom design capabilities and services. Microsemi is headquartered in Aliso Viejo, California, and has approximately 4,800 employees globally. Learn more at www.microsemi.com.

PD-000390461