

# Dual-Axis Motor Control on a Single SoC FPGA

Superior Performance, Reliability, Safety, Security, and Integration Made Easy

Microsemi's motor control solution is designed specially to meet the challenging industrial requirements of performance, reliability, and safety in an easy-to-use environment. Microsemi offers a modular intellectual property (IP) portfolio, tools, reference designs, kits, and software to control motors such as permanent-magnet synchronous motor (PMSM)/brushless DC (BLDC) and stepper motors.

## Motor Control Block Diagram

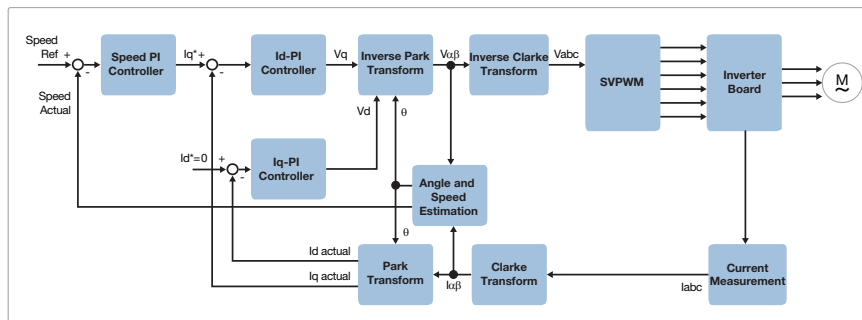

## IP Modules

- Space vector modulation (SVM)
- Three-phase PWM
- FOC transformation IPs (Clarke, Park, Inverse Clarke, and Inverse Park)
- PI controller
- Rate limiter
- Position and speed estimator
- Encoder, Hall, and Resolver interface

## Solutions for Motor Control Block Diagram

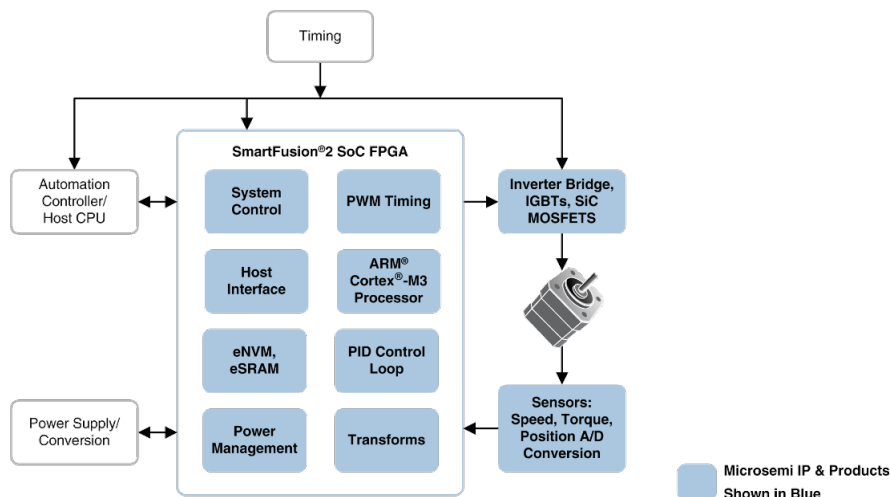

## Reference Design Features

- Motor control algorithms implemented in FPGA fabric
- Scalability to a multi-axis motor drive design
- Design flexibility with modular IP suite
- Deterministic, high-precision, low-power, reliable, and secure
- Robust sensorless solution—supports 100K RPM or more
- Integration of system functions to lower total cost of ownership (TCO)
- Low latency of 1  $\mu$ s for FOC loop from ADC measurement to PWM generation

## Motors and Algorithms

Motor	Algorithm
PMSM/BLDC	FOC sensorless
	FOC with HALL
	FOC with encoder
	FOC with resolver
Stepper	Microstepping

## Fully Modular IP Suite

- Quick plug-and-play approach to implement algorithms
- Easy porting and customization through block-based approach
- Precise algorithm for angle estimation in sensorless FOC
- PWM with dead time protection and delay time insertion
- IP blocks are coded for efficient use of FPGA resources
- IP blocks tested in simulations and on actual hardware
- IPs available as MATLAB models; VHDL Verilog code for FPGA

# Dual-Axis Motor Control on a Single SoC FPGA

Superior Performance, Reliability, Safety, Security, and Integration Made Easy

## High-Performance, Reliable, and Secured Motor Control Solution

Microsemi's SmartFusion®2 SoC-FPGA-based solution is an ideal reference platform for developing high-performance, reliable, and secured dual-axis motor control applications. The solution has algorithms like sensorless FOC, FOC with HALL, FOC with encoder, and FOC with resolver for PMSM/BLDC motors. The position control algorithm of the stepper motor supports up to 1024 micro-steps.

The SmartFusion®2 Motor Control GUI allows for the dynamic tuning of parameters, such as reference speed, Kp/Ki gains of PI controllers, and viewing internal signals for debugging. The kit also supports various communication interfaces, including Ethernet, CAN, USB, and others. SmartFusion®2 SoC FPGAs feature stronger design security than other FPGAs and include differential power analysis (DPA) resistant anti-tamper measures using technology licensed from Cryptography Research Incorporated (CRI). The security architecture was designed with a layered approach in mind, building on top of a foundation of secure hardware.

Microsemi offers a one-stop shop with a portfolio of complementary products to meet your motor control needs. Microsemi's product portfolio includes FPGAs, SiC diodes/MOSFETs, power modules, timing, PoE/Midspans, sensors, and more.

## Ordering Information

SmartFusion2 Dual-Axis Motor Control Starter Kit  
 Part number: SF2-MC-STARTER-KIT

RTL source code for Motor Control IPs  
 Part number: MCSOLCores-RM

For more information, visit  
[www.microsemi.com/applications/motor-control](http://www.microsemi.com/applications/motor-control)

## Software GUI for Motor Control

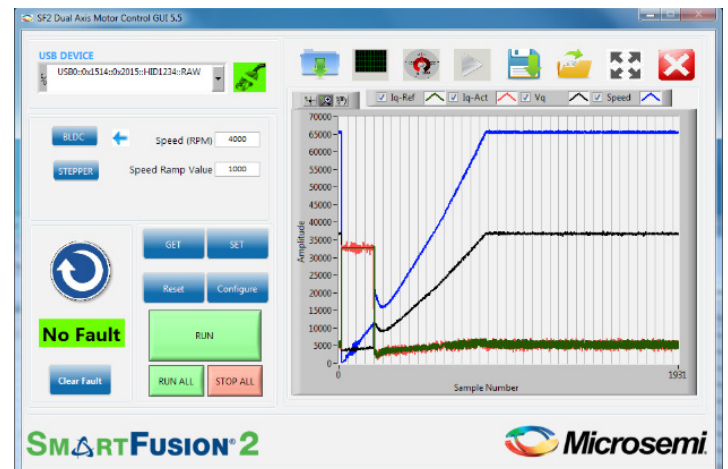

## Dual-Axis Motor Control Board

