

**Application of the MT8843  
Calling Number Identification Circuit 2**

---

**CONTENTS**

ISSUE1

October 1996

**1. Introduction****2. Compliances**

- Bellcore GR-30-CORE
  - Bellcore CIDCW Signalling
  - Challenges in the CIDCW Signalling Environment
- British Telecom SIN 227 and SIN 242
- Cable Communications Association TW/P&E/312 (U.K.)

**3. MT8843 Application Circuit**

- Optimizing the MT8843 for Speech Immunity
  - Guard Time
  - Connecting the MT8843
  - CID/CIDCW Programming

**4. Conclusion****Introduction**

This application note describes the MT8843's functions, its compatibility with telecom standards, and provide some application circuit examples.

Caller ID (CID) is the generic name for a service provided by the telephone companies to deliver information such as the caller's telephone number and/or name to the subscriber at the beginning of a call. A variant Caller ID on Call Waiting (CIDCW) delivers this information about an incoming caller while the subscriber is already engaged in a phone call.

The Caller identity information can be used in many ways. A few examples include tracking who has called over a specified period of time, access data base information on the calling party, trace malicious callers, store number in memory for quick redialling, blocking unwanted calls.

Zarlink's MT8843 (CNIC2) is a device which handles the physical layer protocols used by the central office to transmit the Caller ID information. The protocols are also used to provide other services such as message waiting and ADSI (Analog Display Services Interface). ADSI is a proposed service that allows providers (which can be the telco or other commercial institutions such as banks or ticket agents) to use the protocol to download information onto a display phone. The subscriber then uses buttons around the display to request services from the provider, such as bank account information, purchase concert tickets, or access calling features provided by the phone company.

In most countries, the caller ID information is transmitted in 1200 baud Bell 202 or CCITT V.23 FSK format. The phone or adjunct box demodulates the FSK signal and displays the caller's number and/or name on a liquid crystal display. In addition, the BT caller ID scheme for the U.K. and Bellcore's CIDCW scheme for North America employ a special dual tone signal which is different from DTMF.

The MT8843 is the second generation of caller ID devices available from Zarlink. It offers the following

improvements over the MT8841 (for more information please see the MT8843 data sheet).

- Ring detection
- Line reversal detection
- Dual tone detection (for BT CID and Bellcore CIDCW)
- Two modes of data extraction

The MT8843 offers the option of being powered down when not in use. In power down the ring and line reversal detector remains active. Therefore, when either ringing or line reversal is detected (signalling the beginning of caller ID information) the MT8843 will signal the microcontroller which will in turn power up the MT8843. Once powered up and with FSK demodulation enabled, the MT8843 is ready to interact with the central office.

**Compliances to Standards**

The MT8843 was designed to be used in North America, the U.K. and other countries such as France, Italy, and Japan where 1200 baud Bell 202 or CCITT V.23 format FSK is used to transmit the CID data. The physical layer caller ID specifications in different regions differ even though all provide caller ID information. This application note focuses on U.K. and North American CID. The information should be used only as a reference. Please consult current caller ID documents when implementing a system.

**North American Standard: Bellcore**

North American caller ID services were defined by Bellcore. The documents GR-30-CORE and SR-TSV-002476 specify the CO/CPE interface for caller ID and CIDCW. Figure 1 shows the physical layer signalling for "on-hook data transmission with power ringing" which is employed in CID. The data packet shown is in "Multiple Data Message Format" (MDMF). The packet may also be in "Single Data Message Format" (SDMF) which is shown in Figure 2.

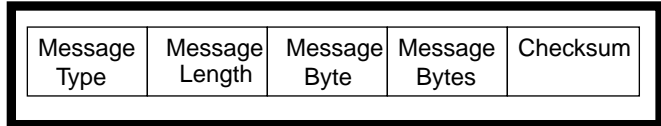

**Figure 2 - Bellcore Single Data Message Format**

The caller ID information is transmitted in 1200 baud Bell 202 format FSK between the first and second ring bursts. The transmitted data stream contains a channel seizure signal, a mark interval, and a data packet which contains the caller ID information. Other information such as the time and date may also be included in the packet. The channel seizure is 300 alternating marks and spaces. The mark interval is 180 bits.

The data transmission must be continuous. If the CO is unable to send data or is waiting for information to become available during the data packet, it will insert up to 10 mark bits between data words. The exceptions are between words in a parameter body in

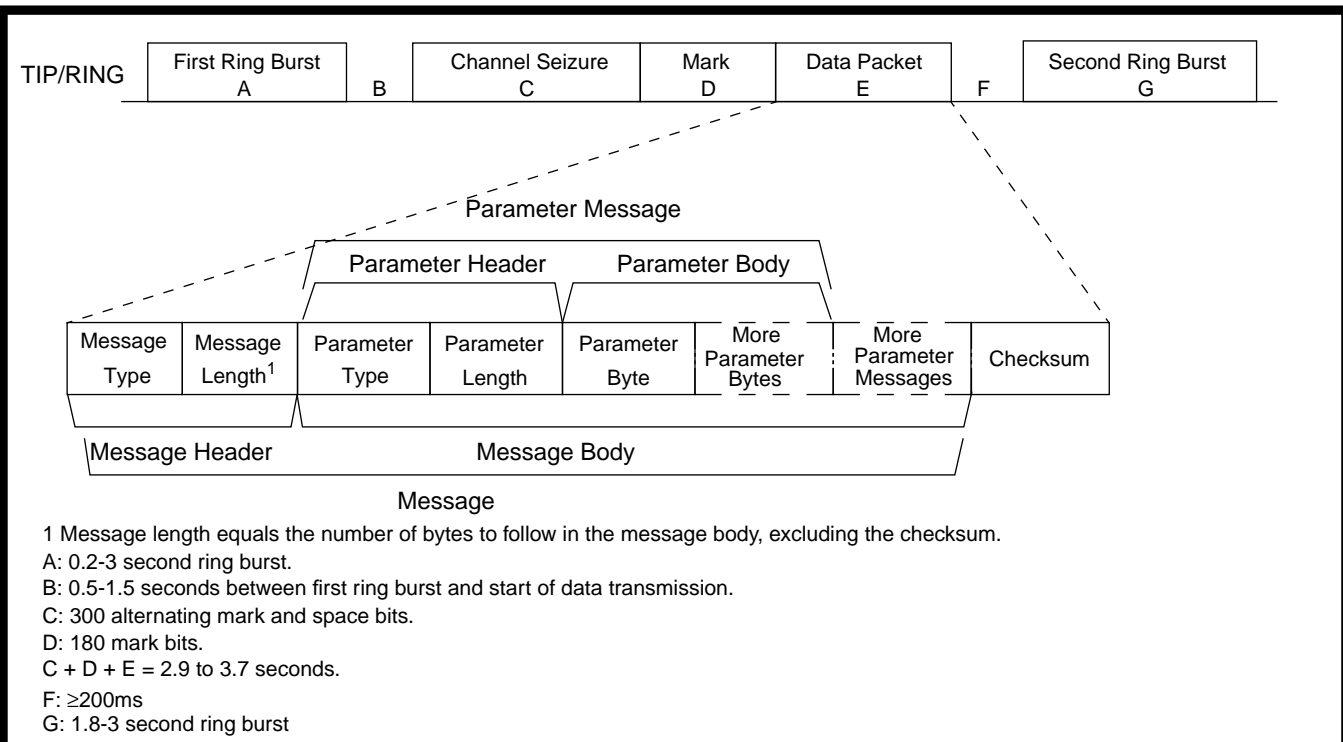

**Figure 1- Bellcore On-hook Caller ID Physical Layer Transmission**

MDMF (see Figure 1) and between message words in SDMF. Figure 3 shows the transmitted word format used by Bellcore, BT, and the CCA.

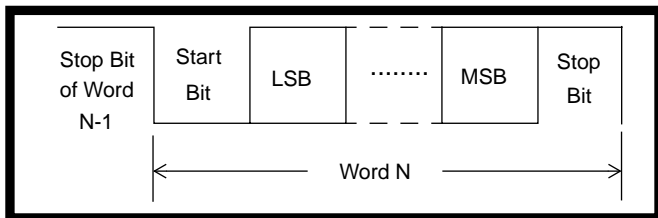

**Figure 3 - Bellcore, BT, and CCA Word Transmission Format**

Error detection is provided by the use of a checksum word transmitted after the last parameter word of the last parameter message (i.e. it is the last word of the transmission). It is the two's complement of the modulo 256 sum of all the preceding words in the data packet (i.e. all message type and length, all parameter type and length, and all parameter words). The modulo 256 sum is computed by adding the words together and then truncating the sum to the least significant (LS) 8 bits. The CPE should calculate the modulo 256 sum of all words received in the message and add it to the received checksum. If the LS 8 bits of the result is non-zero, then the received caller ID data is incorrect. In this case an error message should be displayed because the CO will not retransmit the data.

The MDMF and SDMF message type values appropriate to CID and CIDCW are shown in table 1. Note that both MDMF and SDMF can be used in CID whereas CIDCW uses MDMF only. Therefore in CID, the microcontroller software should check for either 80h or 04h to indicate the beginning of the data packet. In CIDCW, the software should check for 80h only.

Format	Value	Message Type Meaning
MDMF	80h	Call Setup
MDMF	81h	Test for Calling Number Delivery
MDMF	82h	Message Waiting Notification
SDMF	04h	Calling Number Delivery
SDMF	06h	Message Waiting Indicator
SDMF	0Bh	Reserved (for Message Desk Information)

**Table 1. Bellcore Message Type Word Values for CIDCW**

In SMDF, the message words contain the information which the CO needs to transmit to the end user. In MDMF, each message can contain many parameter messages. The parameter type word will be one of

the values in Table 2. The values will depend on what is being transmitted.

Value	Parameter Type Meaning
01h	Time
02h	Calling Line Identification
03h	Reserved (for Dialable Directory Number (DN))
04h	Reason for Absence of DN
05h	Reserved (for Reason for Redirection)
06h	Call Qualifier
07h	Name
08h	Reason for Absence of Name
0Bh	Message Waiting Notification

**Table 2. Bellcore MDMF Parameter Type Word Values for CID and CIDCW**

**Bellcore CIDCW Signalling**

Caller ID on Call Waiting (CIDCW) is a Bellcore feature that allows a subscriber that is already engaged in a telephone call to receive Caller ID information about an incoming call.

The signalling mechanism used is the "off-hook data transmission" protocol defined in Bellcore documents GR-30-CORE and SR-TSV-002476. GR-30-CORE describes the protocol from the CO's perspective; SR-TSV-002476 from the CPE's. In this application note the term "near end" refers to the end of the telephone connection receiving the Caller ID service, "far end" refers to the other end of the established connection.

At the CPE, the signalling sequence for a successful attempt is:

- The CO mutes the connection to and from the far end. Next a Subscriber Alerting Signal (SAS) is applied to the near end. Its purpose is to alert the subscriber to the new call. The SAS shall either be a 440Hz tone applied for 300+/-50ms or a distinctive alerting pattern up to 1 second long. Distinctive alerting occurs when there is interaction with a feature employing a distinctive ringing pattern which the customer subscribes to. The distinctive alerting pattern requirements are described in TR-NWT-000219, "CLASS Feature: Distinctive Ringing/Call Waiting", issue 2, Nov. 1988, Bellcore.

- Next the CO applies a 2130Hz and 2750Hz dual tone for 80+/-5ms. This signal is called the CPE Alerting Signal (CAS). It is intended for alerting the CPE to prepare for the incoming Caller ID data.
- Once the CPE has fully detected the CAS, i.e. the end of CAS has been detected, the CPE should mute the handset and disable the keypad to prevent the forthcoming FSK signals from interference by near end speech, and so that the near end subscriber does not hear the FSK signal.
- Within 100ms after detecting the CAS, the CPE should reply to the CO with an acknowledgement signal (ACK). It is a DTMF digit applied for 60+/-5ms: digit "D" for non-ADSI CPE's, digit "A" for ADSI CPE's. (ADSI is another service promoted by Bellcore. For details see TR-NWT-001273 "Generic Requirements for an SPCS to Customer Premises Equipment Data Interface for Analog Display Services", issue 1, Dec. 92, Bellcore.)
- Before sending ACK, the CPE should check to see if an extension is in use. If an extension is in use, the CPE should not acknowledge the CAS, i.e. should not send ACK.
- Once the CO has detected the ACK, it transmits the caller ID data to the CPE via 1200 baud Bell 202 format FSK signal. Note that there will be no channel seizure signal and the mark interval is only 70-90 bits.
- After receiving the entire FSK signal, the CPE unmutes the handset and enables the keypad within 50ms. The CO also unmutes the far end speech path and the original call resumes. If the subscriber answers the new call via a switch hook flash, the CO will put the original far end party on hold.
- If the CO failed to receive the ACK and/or FSK transmission did not occur because of lack of resource, and the customer is still off hook, the CO will make another attempt after 10 seconds.
- If the CO transmitted the FSK but the subscriber has neither flashed the switch hook nor gone on hook after an interval of 10 seconds (timed from the beginning of FSK), the CO will alert the subscriber once more of the incoming call by providing the SAS only.

Bellcore document TR-NWT-000575 describes the call processing aspects of CIDCW. SR-TSV-002476 should be consulted for CPE timing.

### Challenges in the CIDCW Signalling Environment

The MT8843 has a CAS detector and a FSK demodulator - two essential building blocks in a CIDCW capable CPE. Since the CO can initiate the off hook data transmission protocol any time the CPE is off hook, the CAS detector must be ready to detect as soon as the CPE goes off hook. Thus unlike traditional signal detectors which are connected only for a short time, this detector is exposed to speech during the entire call and must detect the CAS reliably in the presence of speech. The FSK demodulator does not have this problem because it can be shut off when FSK is not expected via the FSK pin. When FSK is expected, there will not be any speech interference because the CO has muted the far end and the CPE has muted the near end. There are two aspects of speech immunity: talkoff and talkdown.

Talkoff is the condition where signals are falsely detected because of imitation by speech or music. An imitation can be caused from the far end or the near end. Talkoff immunity performance is expressed in number of hours per imitation.

Talkdown is the condition where signals are missed because of interference from speech or music. A CAS can be talked down only from the near end because the far end has already been muted by the CO. An example is when the near end talker is speaking while the CAS is being sent. Talkdown immunity performance is expressed in percentage of signals sent being received correctly. Derated miss rate is used in the calculation.

Good talkoff immunity is desirable because whenever a CAS detection has been indicated, the CPE will interrupt the connection with the far end. The CPE mutes the handset, sends ACK which for a false detection will be heard at a loud level at the far end, and waits until FSK has been received or until timed out (about half a second). Hence a false detection interrupts the speech path unnecessarily, and the ACK will be heard at a loud level at the far end. Imitations within a short time are especially objectionable and should be avoided.

Good talkdown immunity is desirable because if the CAS is talked down and not recognized, the CPE will not send ACK. The CO does not receive ACK so it will not send the caller ID information. Thus the subscriber does not receive a service which is paid for.

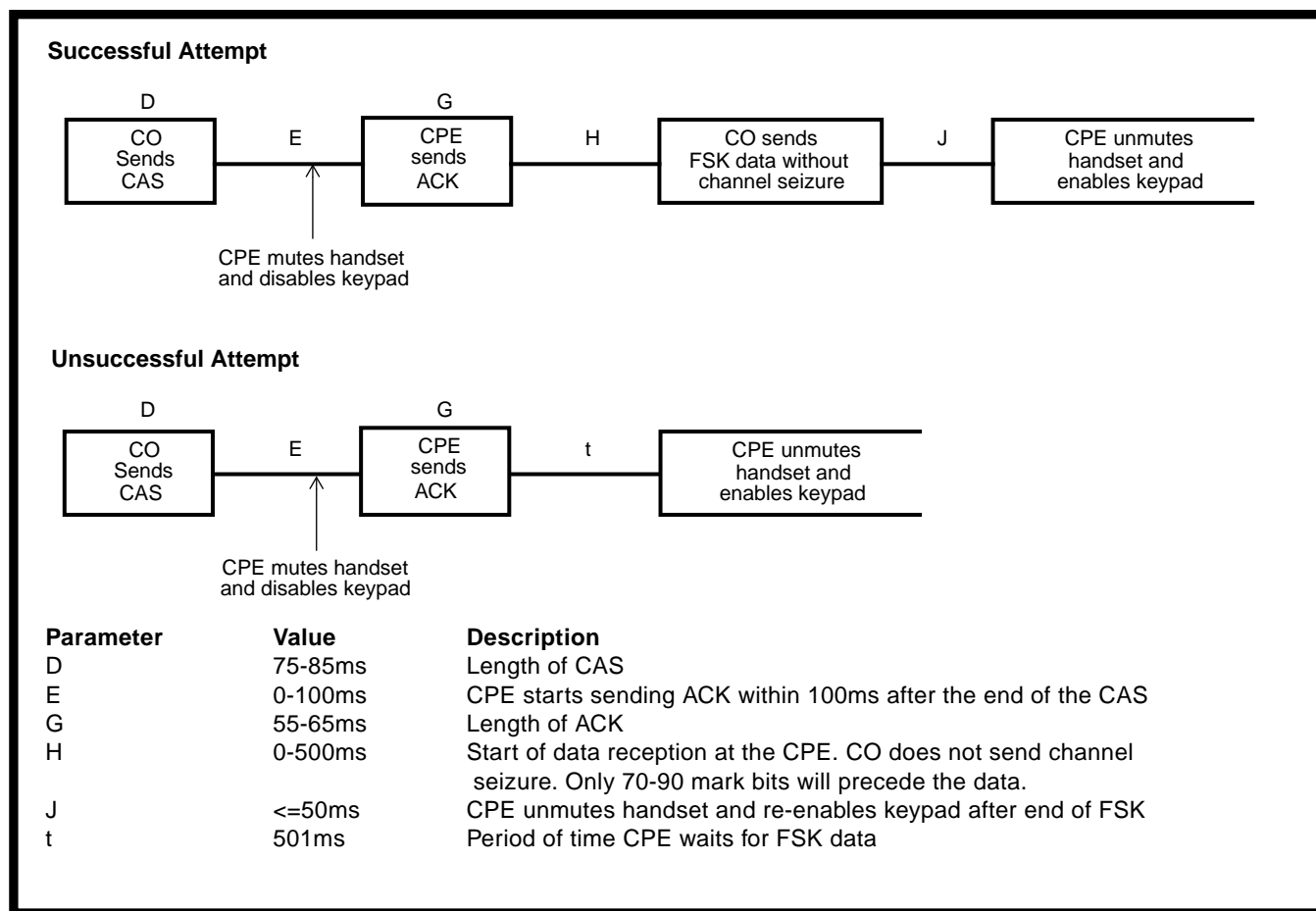

Figure 4 - CPE Timings for Off Hook Data Transmission from SR-TSV-002476

Bellcore has recognized that it is difficult to achieve perfect talkoff and talkdown immunity. To promote customer acceptance of the CIDCW feature, it has specified a set of speech immunity performance objectives in SR-TSV-002476. It has also made available a set of digital audio tapes (SR-TSV-002568) which contains about 95 hours of recorded radio phone-in shows. These tapes aid in test standardization and allow performance comparison between different detector designs.

The set of Bellcore speech immunity requirements is an arbitrary standard. Not meeting it does not mean that the end product will not perform well in the field. Its purpose is to provide a basis for comparing performance amongst different detectors, such as one meeting 70% vs. another which is meeting 30%. Even though the MT8843 does not meet the requirements when it is connected directly to tip and ring, the immunity is quite good. When connected to the receive pair of the telephone hybrid using guard time component values recommended in the "Guard Time" section, the performance is much improved.

**United Kingdom Standards: British Telecom and Cable Communications Association**

Two bodies that have produced Caller ID specifications for the U.K. are British Telecom (BT) and the Cable Communications Association (CCA). BT's specifications are contained in Suppliers Information Notes SIN227 and SIN242. The CCA document is TW/P&E/312.

**U.K. Standard: British Telecom**

Unlike North American caller ID in which the information is transmitted between the first and second rings, BT specifies that CID information should be transmitted before the first ring. 1200 baud CCITT V.23 FSK format is used.

The BT caller ID physical layer signaling is shown in Figure 5. An incoming CDS (Caller Display Service) call is signalled by a reversal of the polarity (line reversal) of the A/B wires. Then the CO sends a special dual tone signal called the Idle State Tone Alert Signal. Upon detection of the dual tone, the CPE should apply an AC termination and a DC load to the line. Afterwards the CO begins data

transmission. The data transmission begins with 96 - 315 alternating mark and space bits, called the channel seizure signal. Channel seizure is followed by a mark interval of at least 55 bits, then the data packet.

The Idle State Tone Alert Signal is a dual tone whose frequencies are 2130/2750Hz ±1.1%. The signal level is -2dBV to -40dBV per tone. The signal duration is 88 to 110 ms.

After 15 - 25 ms has elapsed since the end of the Idle State Tone Alert Signal, AC & DC loads must be switched into the A/B interface. The DC load should draw at least 25mA of DC current for at least 5ms and then be removed. The AC termination specified by BT is shown in Figure 6. It must be removed from the line 50 - 150 ms after the end of FSK data.

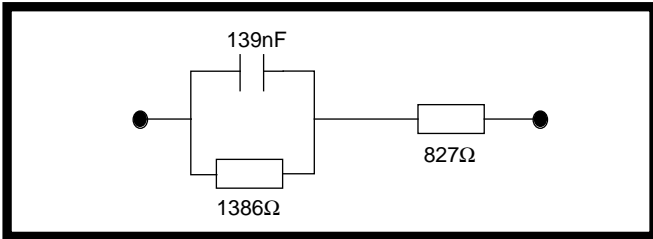

Figure 6 - AC Termination Specified by BT

The data packet format is the same as Bellcore's MDMF. Only one message type value has been assigned. It is shown in Table 3.

Value	Message Type Meaning
80h	Supplementary Information Message

Table 3. Message Type Word Values for BT's CID

The message will contain many parameters. The parameter type word values are shown in table 4.

Value	Parameter Type Meaning
11h	Call Type
01h	Time & Date
02h	Calling Line Directory Number (DN)
03h	Called Directory Number
04h	Reason for Absence of DN
07h	Caller Name/Text
08h	Reason for Absence of Name
13h	Network Message System Status

Table 4. Parameter Type Values for BT's CID

At the end of the FSK data a checksum is transmitted. The CPE should calculate its own checksum by calculating the modulo 256 sum of all bytes starting from the "message type" up to but excluding the checksum. The modulo 256 sum is computed by adding the words together and then truncating the result to the least significant 8 bits.

This calculated checksum should be added to the received checksum. If the LS 8 bits of the result is non-zero, the data has been corrupted.

**U.K. Standard: Cable Communications Association**

In the U.K., cable companies also offer telephone services on their own networks. The Cable Communications Association (CCA) has produced a specification for caller ID terminal requirements in the document TW/P&E/312 as an alternative for British

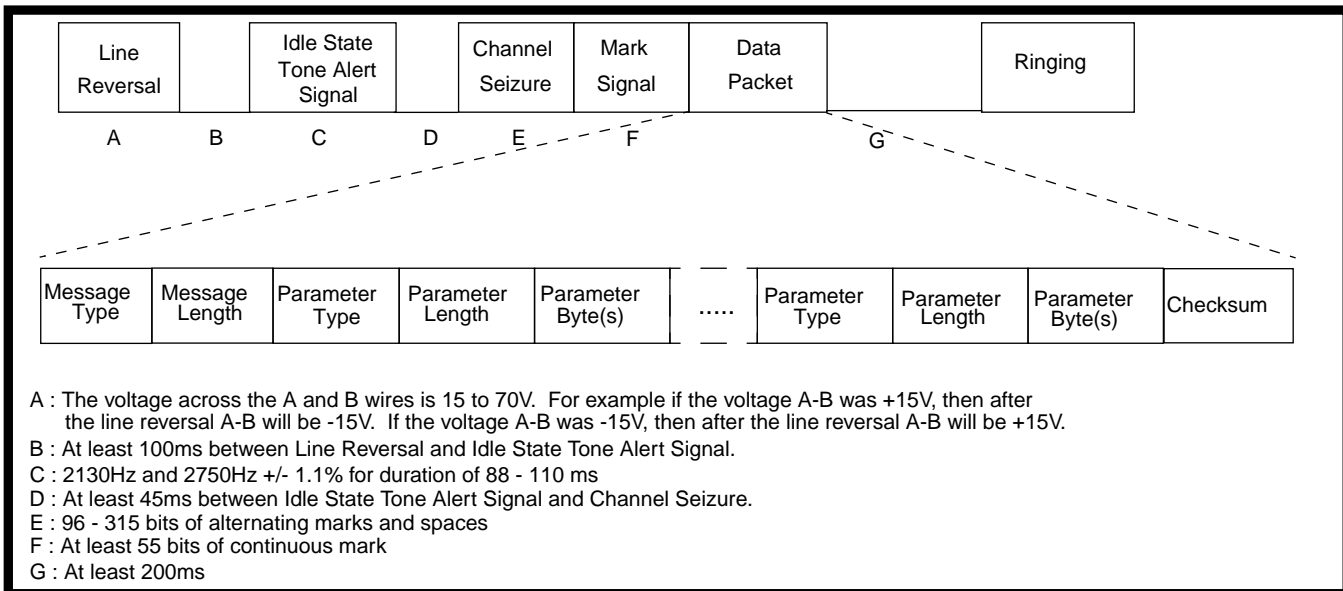

- A : The voltage across the A and B wires is 15 to 70V. For example if the voltage A-B was +15V, then after the line reversal A-B will be -15V. If the voltage A-B was -15V, then after the line reversal A-B will be +15V.
- B : At least 100ms between Line Reversal and Idle State Tone Alert Signal.
- C : 2130Hz and 2750Hz +/- 1.1% for duration of 88 - 110 ms
- D : At least 45ms between Idle State Tone Alert Signal and Channel Seizure.
- E : 96 - 315 bits of alternating marks and spaces
- F : At least 55 bits of continuous mark
- G : At least 200ms

Figure 5: BT Caller ID Physical Layer Transmission

Public Telephone Operators (PTOs) who cannot use the SIN227 interface.

In the CCA caller ID scheme, 1200 baud data (in either Bell 202 or CCITT V.23 FSK format) will be transmitted after a short ring burst. This ring burst will be 200 - 450 ms in duration and 30 - 75Vrms in amplitude. The FSK transmission sequence is channel seizure, continuous mark, and a caller ID data packet which ends with a checksum. The data packet format and checksum are the same as BT's. Channel seizure is 96 to 315 alternating mark and space bits. The mark interval is 55 to 315 bits.

The specification calls for leaving the TE in either the off line idle state or apply AC & DC terminations to the line before the FSK transmission. If applied, the DC termination should be a current drain of up to 0.5mA; the AC termination should be an impedance of at least 2kΩ with an inductive component greater than or equal to 50Ω over the 200 - 4kHz frequency range. These terminations should be removed 50-150ms after the end of FSK within 10ms of each other.

Figure 7 shows the physical layer transmitted signals of the CCA caller ID protocol. The defined values for the Message Type word are shown in table 5. The defined Parameter Type values are shown in table 6. The checksum calculation is the same as the BT case.

Value	Message Type Meaning
80h	Call Setup message
81h	Non-Call Setup message
82h	Message Waiting message

Table 5. Message Type Word Values for CCA CID

Value	Parameter Type Meaning
11h	Call Type (Voice Call or Ring Back When Free Call)
0Bh	Call Type (Message Waiting Call)
04h	Reason for absence of caller number (Caller Number Unavailable or Caller Number Withheld)
08h	Reason for absence of caller name (Caller Name Withheld)
01h	Time and Date
02h	Calling Line Directory Number
03h	Called Line Directory Number
07h	Caller Name/Text

Table 6. Parameter Type Values for CCA CID

### MT8843 Application Circuit

The MT8843 line interface circuit shown in Figure 8 will meet the requirements of Bellcore, BT, and CCA standards. It will provide high voltage isolation, common mode TIP/RING signal rejection (via the input opamp in differential mode), common mode noise immunity for the ring detector (via an opto-coupler), ringing, line reversal, and CAS/BT Tone Alert signal detection, and FSK demodulation.

The high voltage isolation is attained via resistors R1 and R3 and capacitors C1 and C2. Both the resistors and the capacitors have a high voltage rating. The high impedance components limit the current and diodes D1 through D4 limit the voltage. The ring detector is AC coupled to the line via R6 and C3. The ringing detector achieves isolation via the opto-isolator, resistor R6 and capacitor C3. Resistor R6

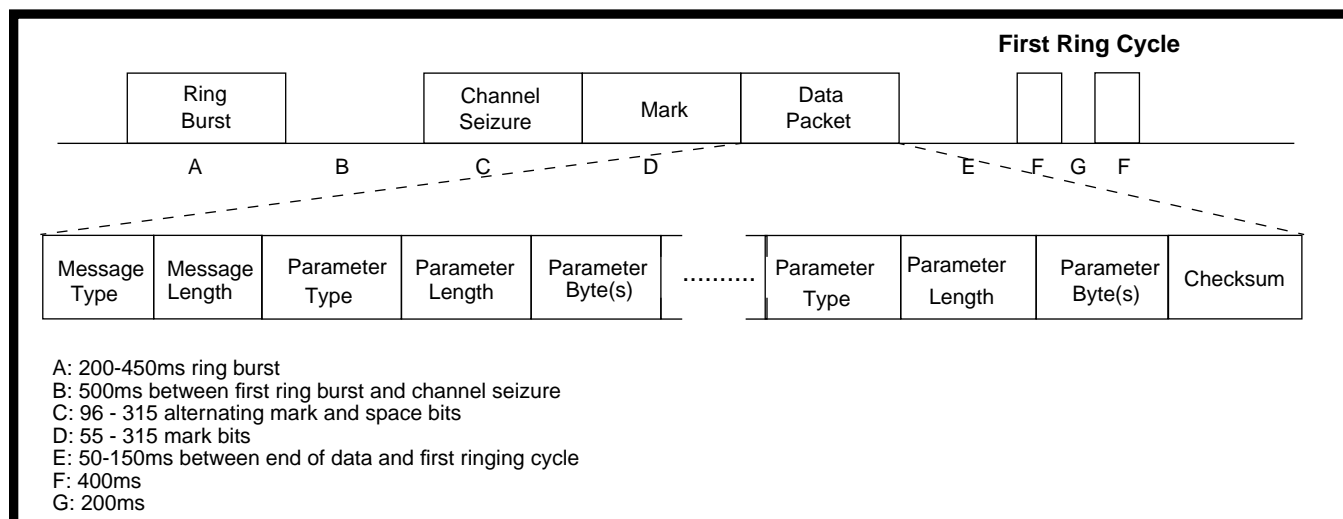

Figure 7 - CCA Caller ID Physical Layer Transmission

has a high power rating and is a fuseable type, therefore it will open when its power rating is exceeded. Capacitor C3 has a high voltage rating.

The component values were chosen to provide protection for the user as well as the low voltage circuitry from high voltage fault conditions which may occur on the line. The circuit was simulated to ensure that it met the line interface requirements specified in FCC Part 68, DOC CS-03, UL 1459, CSA C22.2 and BS 6301.

The diode bridge connected to the MT8843's ring detector will provide full wave rectification of ringing and provide line reversal detection. The opto-coupler will reject common mode signals, preventing false ring detection. When the opto-coupler is activated, capacitor C10 charges through resistor R13 towards the signal detection level of the TRIGin pin. The RC time constant of C10 and R13 will determine how quickly the ring detector will respond to ringing and line reversal signals.

Caller ID data will be transmitted from the central office in Bell202 or CCITT V.23 format FSK. The FSK signal will be differentially amplified by the MT8843's internal opamp. The MT8843's opamp as shown in Figure 8 is redrawn and shown in Figure 9.

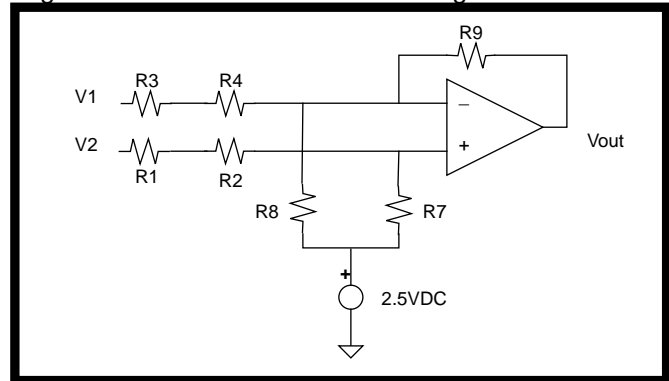

Figure 9 - MT8843 Differential Operational Amplifier

The configuration of this circuit was designed to provide superior common mode rejection for high input voltages.

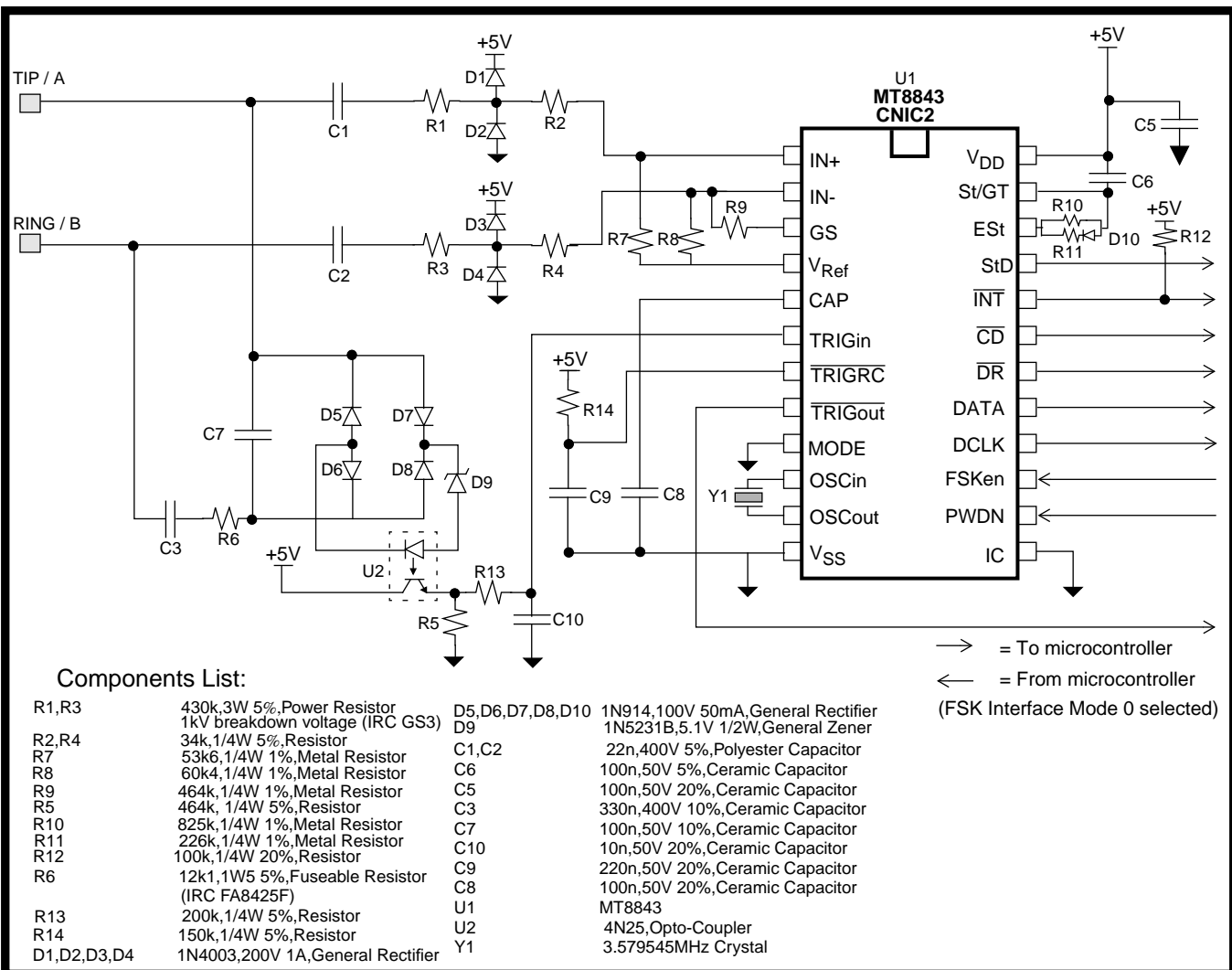

Figure 8: Line Interface Circuit for MT8843



Analyzing the circuit shown in Figure 9 using the Superposition theorem produces the inverting opamp case shown in Figure 10 and the non-inverting case shown in Figure 11. Note that the 2.5V source has been replaced with a ground since it is only a DC offset voltage. In the inverting case the voltage across R8 is zero so it will be ignored in the inverting opamp equations.

To accomplish common mode rejection of large input signals the input is first attenuated and then amplified so that unity gain is maintained.

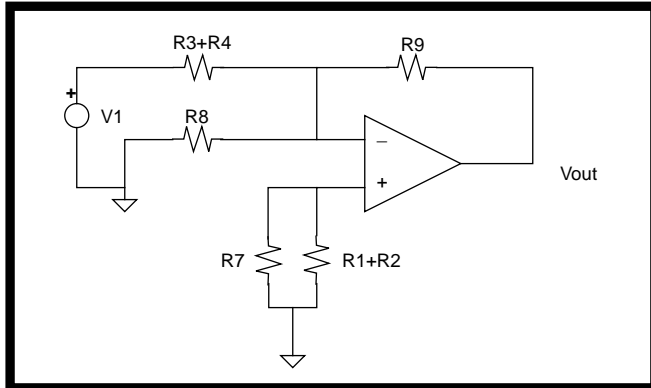

Figure 10: Inverting Case of Figure 8 Opamp

The gain of the inverting circuit in Figure 10 is

$$A_{V_{inv}} = \frac{V_{out}}{V_1} = -\frac{R_9}{R_3 + R_4}$$

Since R9=464kΩ R3=430kΩ R4=34kΩ

$$A_{V_{inv}} = -\frac{464k}{464k} = -1$$

The non-inverting opamp case is shown in Figure 11.

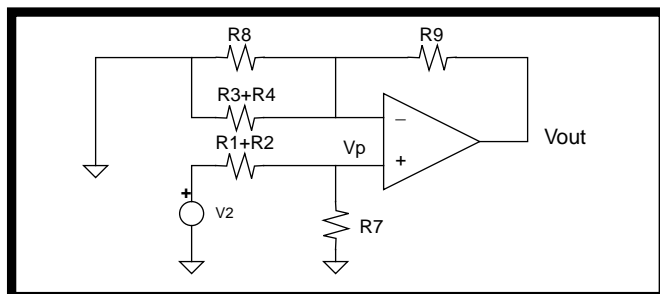

Figure 11 - Non-Inverting Case of Figure 8 Opamp

The V2 input voltage is attenuated by the voltage divider so that

$$V_p = V_2 \left( \frac{R_7}{R_7 + (R_1 + R_2)} \right)$$

Note from Figure 11 that resistor R8 is in parallel with resistors R3 and R4. This parallel combination will result in an increase in the non-inverting opamp gain

$$A_{V_{non-inv}} = \frac{V_{out}}{V_p} = 1 + \left( \frac{R_9}{R_8 \parallel (R_3 + R_4)} \right)$$

Since V2 is attenuated by a factor of:

$$\frac{R_7}{R_7 + R_1 + R_2} = \frac{53k6}{53k6 + 430k + 34k} = 0.103$$

The non-inverting gain must be 1/0.103 = 9.66 to achieve an overall gain of unity with respect to V2. Thus

$$9.66 = 1 + \frac{R_9}{R_8 \parallel (R_3 + R_4)}$$

Since R3+R4=464kΩ and R9=464kΩ

$$9.66 = 1 + \frac{464k\Omega}{R_8 \parallel 464k\Omega}$$

$$\therefore R_8 = 60k4\Omega$$

Since the opamp common mode range is 3Vpp, the maximum common mode input signal that this circuit can cancel is 3Vpp/0.103=29Vpp=10.2Vrms.

Figure 12 shows a method for connecting the MT8843 operating in mode 0 to an Intel 8051 microcontroller via a shift register. In this mode the MT8843 will clock the serial data into the shift register. The decoded FSK bit stream will be output on the DATA line as soon as it is demodulated. 1200Hz clock pulses on the DCLK line will only clock the data bits into the shift register. At the end of the 8-bit data word the  $\overline{DR}$  pin will change to a logic low, which will cause the shift register to parallel load the data onto its output. This parallel data is read by the microcontroller. The microcontroller will then output caller ID data to a Liquid Crystal Display (LCD) for the user to view.

The microcontroller will be signalled by StD when CAS/Tone Alert Signal is detected,  $\overline{CD}$  for FSK, TRIGout for ringing or line reversal, and  $\overline{INT}$  for MT8843 interrupt request. The microcontroller must keep track of these signals so that it can correctly interpret the progress of the caller ID protocol. The microcontroller has the ability to power up or power down the MT8843 via the PWDN pin connection. In a battery application, the MT8843 should be powered down when not in use to

conserve power. The ringing/line reversal detector is not affected by power down, so when the beginning of the caller ID protocol is detected, the MT8843 can signal the microcontroller to power it up.

The microcontroller can enable or disable FSK demodulation via the FSKen pin connection. BT, CCA, and Bellcore have specified the times in their caller ID protocols when FSK will be available. The FSK demodulator should be disabled when FSK data is not expected. Doing so will ensure that signals such as voice and DTMF tones which are in the frequency range of FSK will not be demodulated and generate false data.

Figure 13 shows a symbolic circuit in which the MT8843's microcontroller is connected so that data can be recovered in mode 1. In this mode the  $\overline{DR}$  pin will go to a logic low indicating the presence of available data in the MT8843. The microcontroller must supply eight clock pulses to read the 8-bit word. The word is clocked serially out of the MT8843 by the read pulse rising edge in the order the bits were received, i.e. LSB first. If a word has not been fully retrieved from the MT8843's internal data register

before the end of the next word (i.e. the next  $\overline{DR}$  low), it will be overwritten.

Since the MT8843 is dealing with BT, the U.K.'s CCA, and Bellcore caller ID protocols, the microcontroller must be able to keep track of when signals such as ringing, line reversal, and alerting tones occur. This way, the MT8843 can be powered up and FSK demodulation enabled at the correct time.

**Optimizing the MT8843 for Speech Immunity**

In CIDCW, the subscriber who is to receive the Caller ID information may be talking when the CAS is sent from the CO. Therefore CAS detection must be performed when the CAS is interfered by speech. The ability of the detector to detect CAS when interfered by speech is measured by the "talkdown" performance. CAS may also be imitated by speech from both the subscriber (near end) and the connected party (far end). The likelihood of such imitations is measured by the "talkoff" performance. Two factors affect the MT8843's speech immunity:

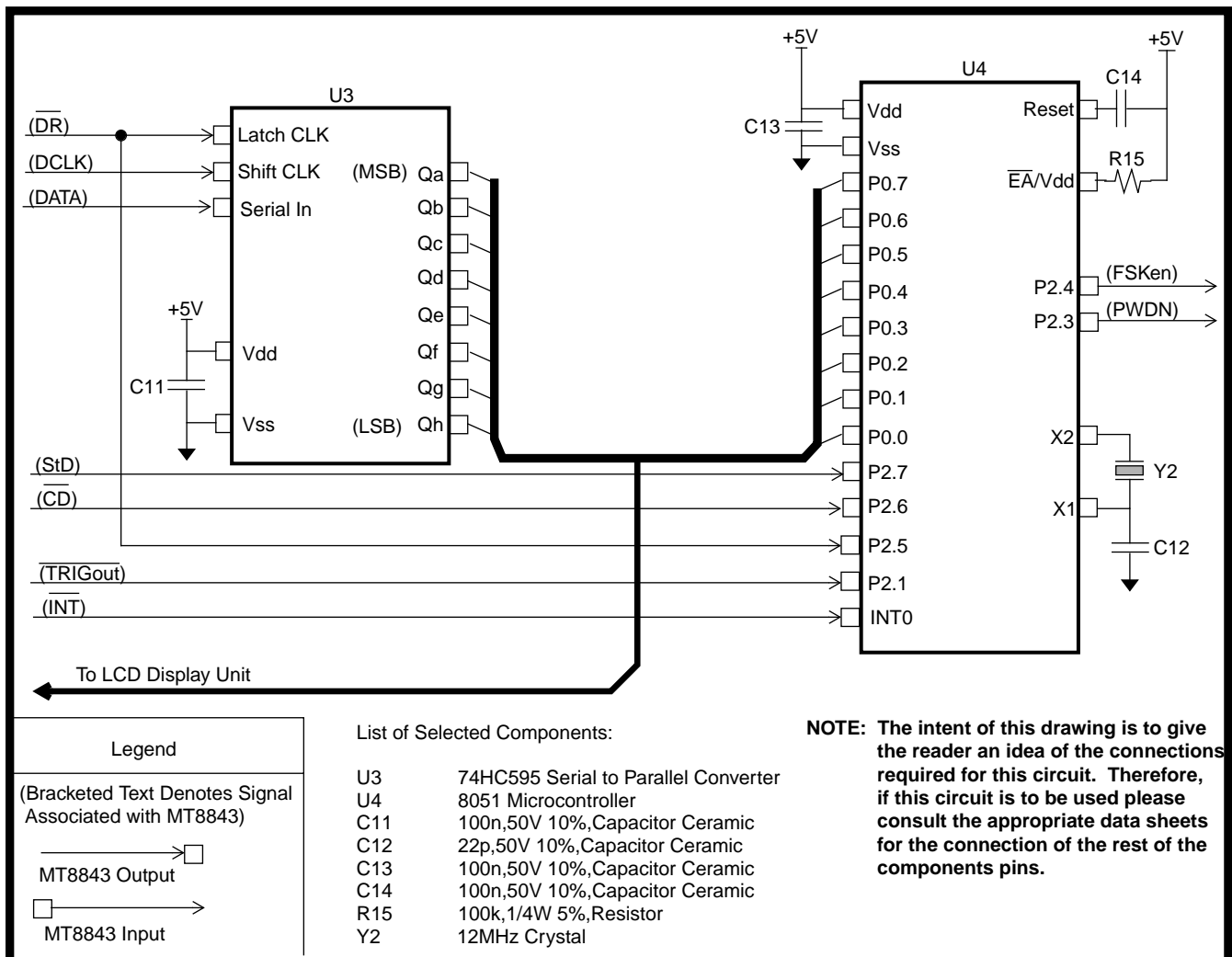

Figure 12: Microcontroller Interface for MT8843, Mode 0 Operation.

the detect guard time and whether the MT8843 is connected directly to tip and ring or to the receive pair of a telephone hybrid.

**Guard Time**

Part of the MT8843 speech immunity strategy is to qualify the detection of dual tones with a duration called the detect guard time  $t_{GP}$ . The Est pin goes high when the signal at the MT8843 analog inputs meets the CAS frequency tolerance requirements. When Est has been high continuously for the detect guard time, the detection is classified as a CAS. StD then goes high to indicate that CAS has been detected (time A in Figure 14). Once StD has gone high, momentary Est dropouts which do not exceed the absent guard time  $t_{GA}$  are tolerated (times B and C in Figure 14). That is, Est must be low continuously for  $t_{GA}$  in order for StD to return low to signify the end of CAS (time F in Figure 14). For a CAS which is interfered by speech, once StD has gone high Est dropouts caused by speech interference will be tolerated for up to  $t_{GA}$  so the end of CAS will not be signalled prematurely (times B and C in Figure 14).

The longer  $t_{GP}$  is the harder it is for speech to imitate CAS. Conversely, detection of valid signals which are corrupted by speech is more difficult if  $t_{GP}$  is long.

Therefore a longer  $t_{GP}$  improves talkoff but degrades talkdown. It is a trade off.

It is recommended that for optimal speech immunity  $R_{10}$  should be 825K,  $R_{11}$  226K and  $C_6$  0.1uF (Figure 8). These components will give a 66ms  $t_{GP}$  15ms  $t_{GA}$ . Since the minimum CAS duration is 75ms and Est takes typically 3 to 4ms to react, 66ms is about the maximum  $t_{GP}$  possible.

Figure 14 shows the relationship between the MT8843's Est and StD timing. Once the MT8843 has detected a signal in the CAS frequencies Est will go high. When Est has been high for the present guard time ( $t_{GP}$ ), StD will go high (time A). The absent guard time  $t_{GA}$  allows momentary Est drop out without changing the state of the StD pin (times B and C).

At the end of the CAS, sometimes speech will cause spurious high pulses on the Est signal. If the time between these pulses is less than  $t_{GA}$  (times D and E), StD will not return low properly to signify the end of CAS. In this situation if the CPE monitors the StD falling edge to start sending ACK, the ACK may not be sent within 100ms after the end of CAS as required by the Bellcore protocol and the CO will not transmit the caller ID data. StD will only return low once Est has been continuously low for  $t_{GA}$  (time F).

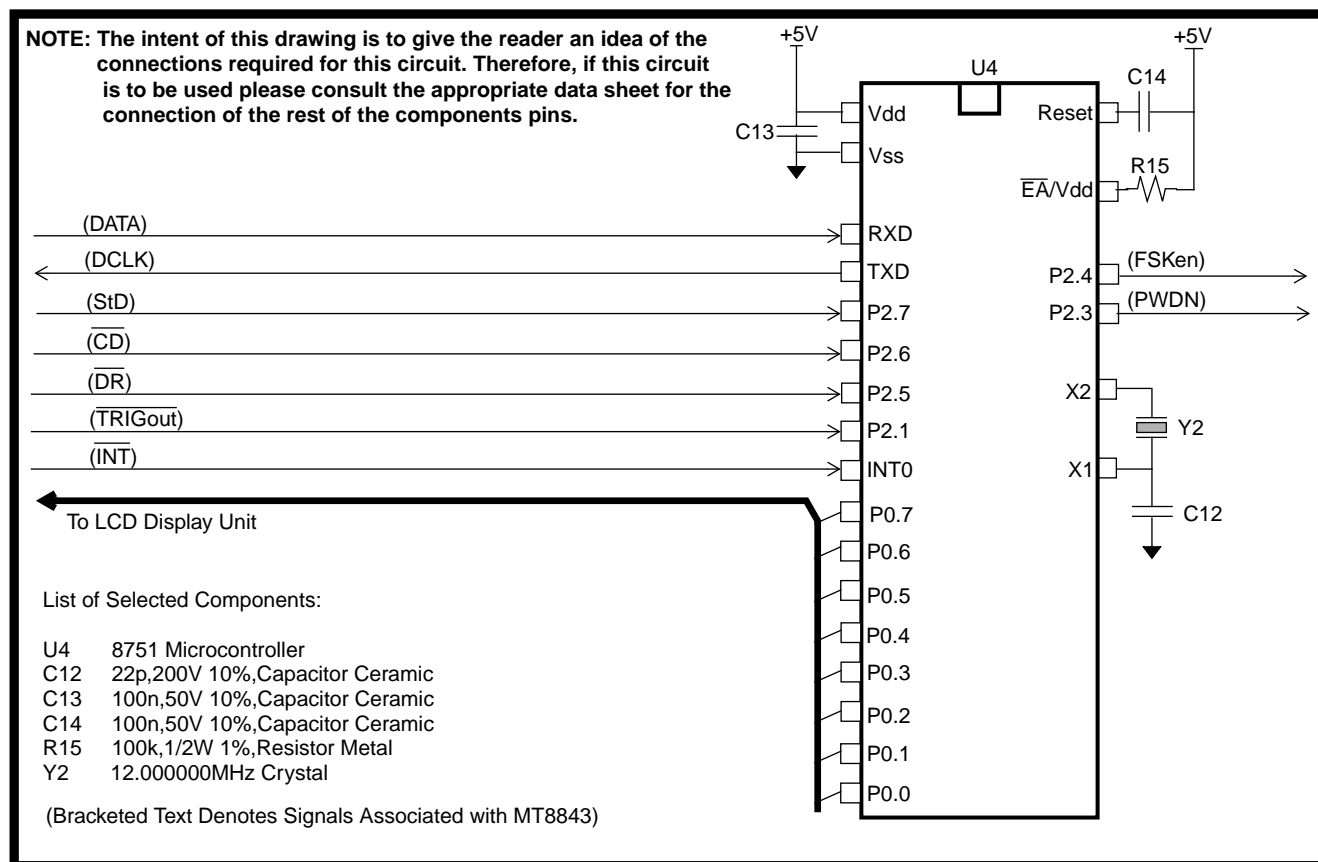

**Figure 13 - Microcontroller Interface for MT8843, Mode 1 Operation.**

To ensure that the ACK is sent in time the following scheme should be used. Since CAS is at least 75ms long, and a time  $t_{GP}$  has already elapsed before the MT8843 classifies it as a CAS and set StD high, then the earliest time CAS can end is at  $(75ms - t_{GP})$  after the StD rising edge. The CPE's microprocessor should mute the near end speech path, typically by disconnecting the microphone, at  $(75ms - t_{GP})$  after the StD rising edge. Once the near end speech has been muted, ESt will not go high spuriously because there is no speech and StD will return low at a time  $t_{GA}$  after the end of CAS.

Alternatively, the microprocessor does not mute the near end speech but  $t_{GA}$  is set very short: 1 or 2ms. For example a  $26k1\Omega R_{11}$  will give a 2.3ms  $t_{GA}$ . Then ESt only has to remain low for a short time at the end of CAS and it is less likely that StD will be kept high beyond the end of CAS by spurious ESt activity. Since the optimal speech immunity  $t_{GP}$  is long (66ms), ESt dropout during a CAS after StD has become high is not a concern so  $t_{GA}$  can be short.

In an electrically noisy environment such as inside a PC, the noise may cause spurious high pulses on the ESt signal at the end of CAS and cause StD to fail to return low to indicate the end of CAS. In this case the microprocessor should send ACK at  $(85ms - t_{GP}) + 20ms$  after the StD rising edge. The 20ms is a margin to ensure that CAS has ended.

Some musical passages on the Bellcore test tapes generate multiple imitations within a short interval, usually within 2 seconds. That is, the imitations are

clustered together. Clustered imitations can be consolidated into one imitation by adopting a simple algorithm. Upon each detection, start a 2 second window during which further detections are ignored. An imitation during that window should restart the window. Thus each cluster will be consolidated into a single imitation such that the number of imitations will be reduced. In CIDCW, if the first CAS is not acknowledged the CO will try again after 10 seconds. Therefore real CASes are at least ten seconds apart.

The detect and absent guard times  $t_{GP}$  and  $t_{GA}$  are implemented with RC components as shown in the application circuit (see Figure 8, R10, R11, and C6). Alternatively the CPE's microprocessor can be used to implement the guard times. The algorithm is shown in Figure 15. "SoftStD" is equivalent to the StD pin function. SoftStD equal one is equivalent to a logic high at the StD pin which indicates that a CAS has been detected. The ESt pin should be sampled periodically. The sampling period should be 1.4ms or less.

**Connecting the MT8843**

One way to improve the MT8843's speech immunity is to reduce the near end speech level. When the near end speech is attenuated, there is less speech to interfere with CAS detection so talkdown improves. Note that far end speech does not interfere with CAS detection because the CO has muted the far end when it sends CAS.

Near end talkoff also benefits because imitation is less likely from the lowered near end speech power.

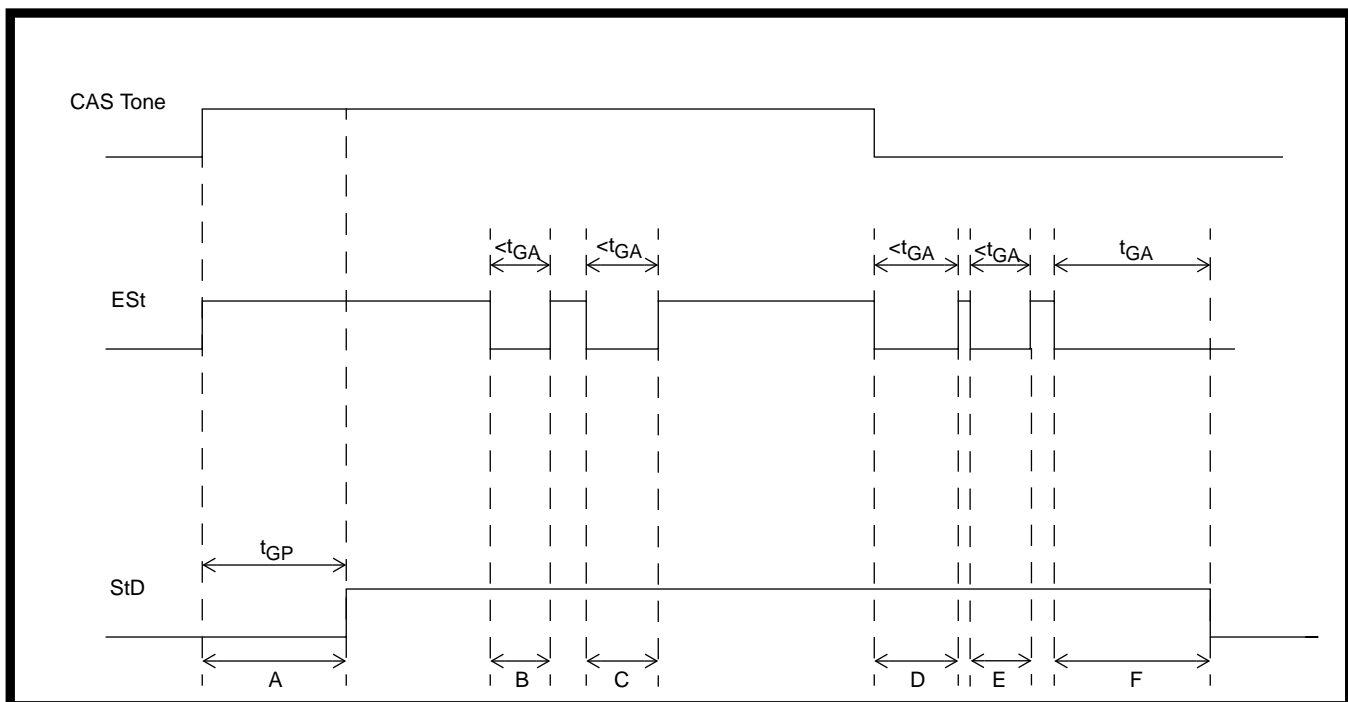

Figure 14 - MT8843 ESt and StD Timing Relationship

Improving near end talkoff greatly improves the overall talkoff performance because the MT8843 is less likely to be talked off by the far end. At the same speech level far end talkoff is less compared to the near end because there is no pre-emphasis on the far end speech. The pre-emphasis imparted on the far end speech by the far end telephone has been equalized by the high frequency attenuation characteristics of two subscriber loops. One loop connecting the far end telephone to the far end CO, the other connecting the near end CO to the near end telephone.

balancing impedance ZB matches the loop impedance ZL, i.e.  $ZB=ZL$ , then the speech transmitted at VTx will not appear across VRx. Because of the great variety of customer loops installed, it is difficult to perfectly match every line. In SR-3004 section 4.1.1, Bellcore has suggested eight test loops. Using SPICE the hybrid circuit was simulated with each of the eight loops in place of ZL. ZB was varied to determine its optimal matching value. The simulations were performed at the frequencies 2106.57Hz (2130Hz - 1.1%) and 2780.25Hz (2750Hz + 1.1%). It was found that if  $ZB=1k\Omega$  the minimum attenuation is 7.83dB. The 1k $\Omega$  value had the best matching characteristics of the ZB values tried. The results of the SPICE simulations are shown in table 7.

Figure 16 shows a symbolic telephone hybrid with the telephone transmitter VTx and receiver VRx. If the

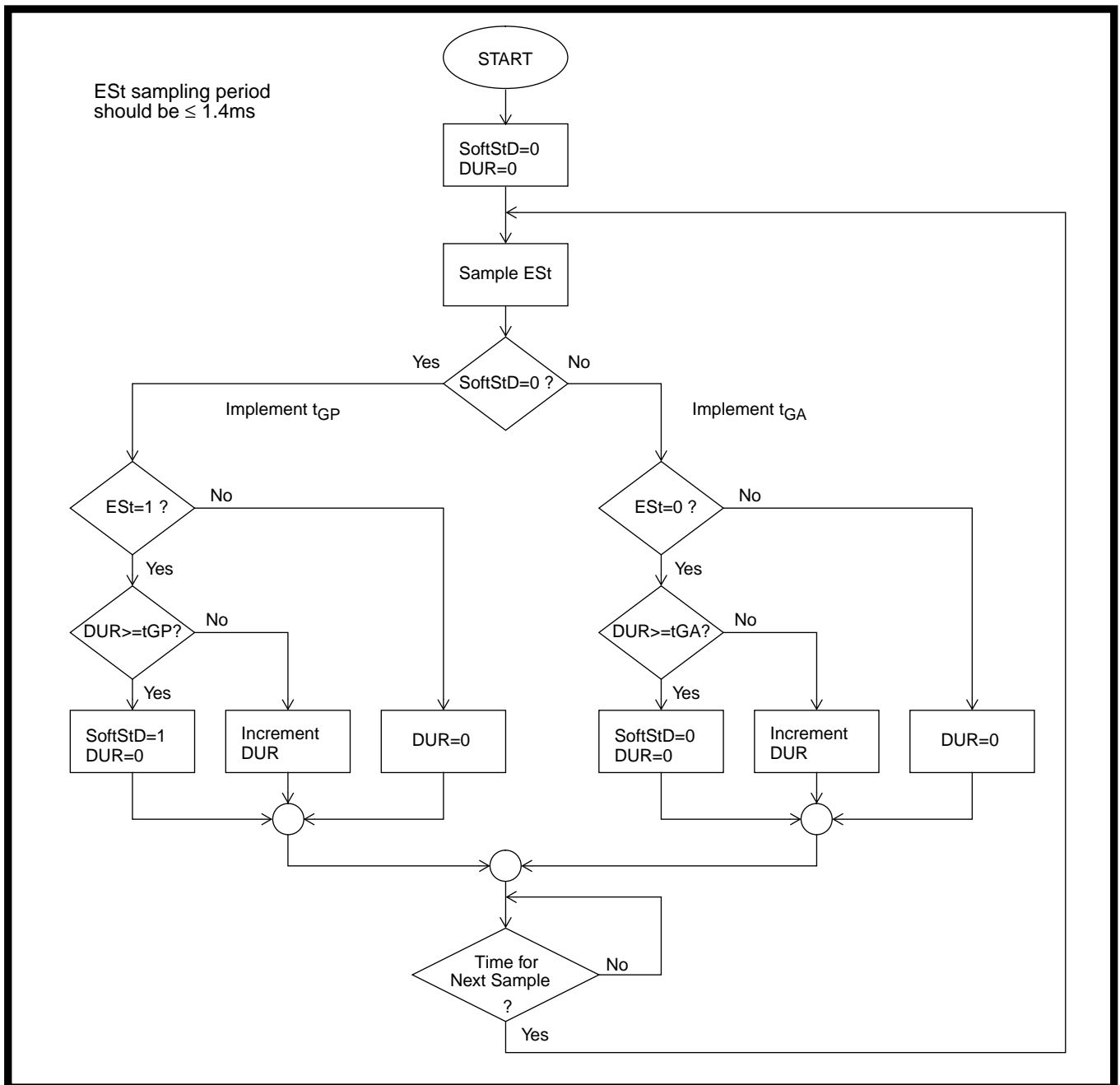
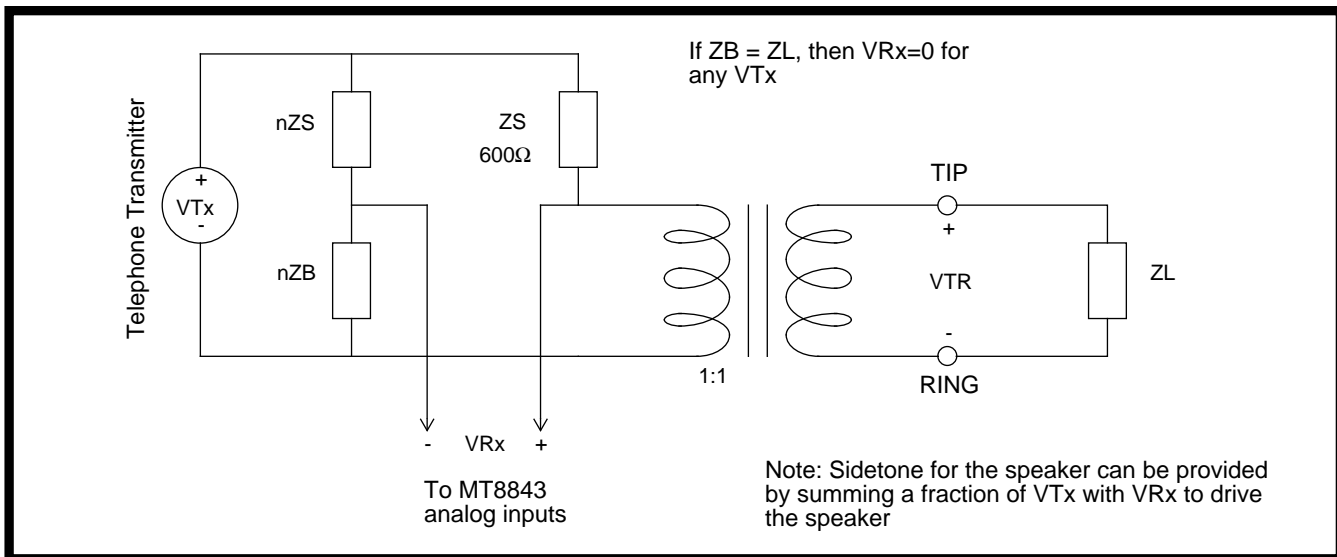

Figure 15 - Software Guard Time Algorithm



**Figure 16 - Telephone Hybrid**

In Figure 16, the MT8843 is said to be connected to the "4-wire side" of the telephone hybrid. When testing a CPE where the MT8843 is connected to the four wire side, the test loop providing the least amount of attenuation should be connected to the CPE.

**CID/CIDCW Programming**

In a CID or CIDCW capable CPE, many events require the microcontroller's attention: e.g. switch hook, keypad and timers. The MT8843 interrupts when an FSK word is available (provided that FSK demodulation has been enabled via FSKen=1), CAS detected, and ringing or line reversal detected. If the software is interrupt driven, then upon interrupt the MT8843 DR, StD and TRIGout pins (respectively)

should be checked to determine the appropriate action.

Even though potentially many events may request service, only some of them are valid at various call states. For example, of the 3 events which cause the MT8843 to interrupt, only detection of ringing and line reversal (indicated by  $\overline{\text{TRIGout}}=0$ ) is relevant when the CPE is on hook. Therefore when the CPE is on hook, the software need not poll StD and  $\overline{\text{DR}}$  pins. If the software is interrupt driven, action is required only when  $\overline{\text{TRIGout}}$  is found to be the cause.

Upon system power up, the microcontroller will perform system initialization. Afterwards it will either poll the signals in the system which indicate that service is required or wait for interrupt. Note that on system power up the MT8843 will generate a false interrupt as described under the "interrupt" section of the data sheet. This interrupt should be ignored.

ZL (Bellcore SR3004 Loop)	Attenuation (dB) <sup>1</sup> for Z <sub>B</sub> = 1kΩ	
	at 2106.57Hz	at 2780.25Hz
A	13.02	10
D	8.57	9.02
E	13.85	12.51
F	13.02	12.4
G	8.001	7.83
B	13.59	11.8
C	12.89	9.06
H	14.37	8.69

**Table 7. SPICE Simulation Results when Hybrid Circuit (Figure 16) is Connected to Bellcore Test Loops**

<sup>1</sup> Attenuation = 20 log(VT<sub>X</sub>/VR<sub>X</sub>)

The functions described in the following sections are intended to be starting points for CID and CIDCW software. They are by no means exhaustive. For detailed requirements please consult SR-3004 for Bellcore, SIN242 for BT, TW/P&E/312 for CCA.

### Programming for CID

When the MT8843 detects ringing or line reversal, signalling the beginning of CID data transmission, the  $\overline{\text{TRIGout}}$  pin will be set low and an interrupt generated. Note that the MT8843 uses the  $\overline{\text{TRIGout}}$  pin to indicate both the detection of ringing and line reversal. For protocols where ringing is used as the start of CID signalling and where line reversal may incidentally occur (e.g. CCA), there is no need to distinguish between the two. When  $\overline{\text{TRIGout}}$  goes low the CID service routine should be entered. If another  $\overline{\text{TRIGout}}$  occurred during the service routine, the routine should be restarted. In BT's case (which uses both ringing and line reversal in its protocol), there is no need to distinguish between ringing and line reversal because the service routine will not prepare for FSK until the Idle State Tone Alert Signal has been received. If another  $\overline{\text{TRIGout}}$  occurred before the tone alert signal has been detected, the software should simply restart the CID service routine.

The software should not have to identify whether it is to interact with BT or Bellcore/CCA protocol from the signalling itself. It should determine the requirement by reading a hardwired bit during system initialization or upon entry into the CID service routine.

The CID protocol service routine flow chart is shown in Figure 17. The tasks are:

- Power up the MT8843 via PWDN=0.  
Bellcore: Start a timer to timeout in 7 seconds. This is the time within which channel seizure should begin. It is the sum of a 3 second ringing on time and a delay of up to 4 seconds from the end of ringing to channel seizure. Exit from the CID service routine if the timer expires before channel seizure occurred. Restart the routine if  $\overline{\text{TRIGout}}$  is asserted.  
BT: Start a timer to timeout in 5 seconds. Wait for detection of the Idle State Tone Alert Signal (indicated by the StD pin). Exit from the CID routine if the timer expires. Once the signal has been received, apply the DC current wetting pulse and the AC termination. Restart the timer to timeout in 5 seconds. This is the time within which the channel seizure should begin. Exit from the CID service routine if the timer expires. Restart routine if  $\overline{\text{TRIGout}}$  is asserted.

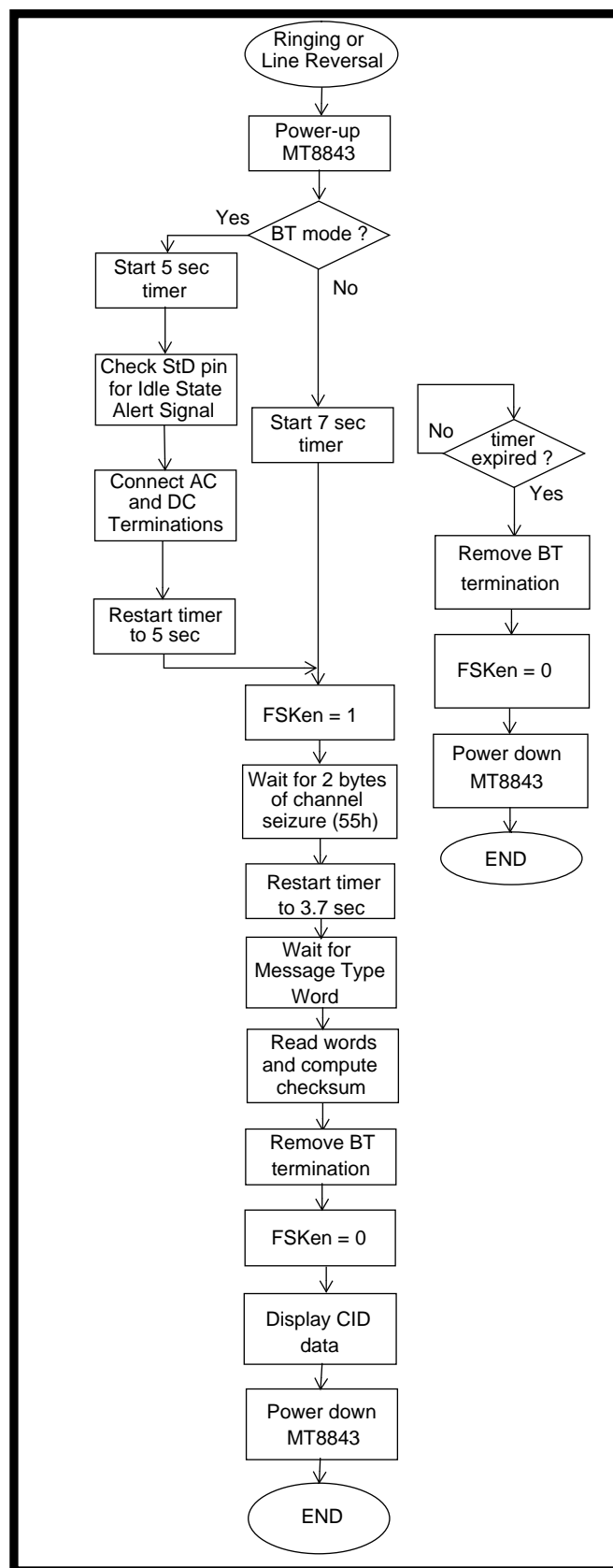

Figure 17 - Bellcore, BT, and CCA CID Flowchart

- Set FSKen=1. Wait for and verify the channel seizure by looking for 2 consecutive bytes of 55h in the demodulated FSK data. Once channel seizure has been verified, restart timer to timeout in 3.7 seconds (time C+D+E in Figure 1). FSK reception should finish before the timer expires. The CID service routine does not distinguish between the first and subsequent rings. In the Bellcore case when the phone is picked up after the second ring, speech will cause the FSK demodulator to pump out false data. Without verification via channel seizure, the false data may imitate the message type word, the message type word and cause the CPE to display "data error".
- Look for the message type word 80h or 04h in Bellcore's case, 80h only otherwise.
- Read the message length word.
- Read number of words specified by the message length and calculate the checksum. Read transmitted checksum and add to calculated checksum. The sum should be 0.
- Remove AC and DC termination in BT or CCA case. Set FSKen=0. Display Caller ID message. Power down the MT8843 via PWDN=1. Exit service routine.

**Programming for CIDCW**

After the CPE has gone off hook, the MT8843 should be powered up by setting the PWDN pin low. FSKen should be kept low so that false data caused by speech does not cause any activity at the DR output (which generates interrupts).

The starting point for servicing the CIDCW protocol is the detection of CAS indicated by either polling the MT8843 StD pin or an interrupt from the MT8843. The CIDCW protocol service flow chart is shown in Figure 18.

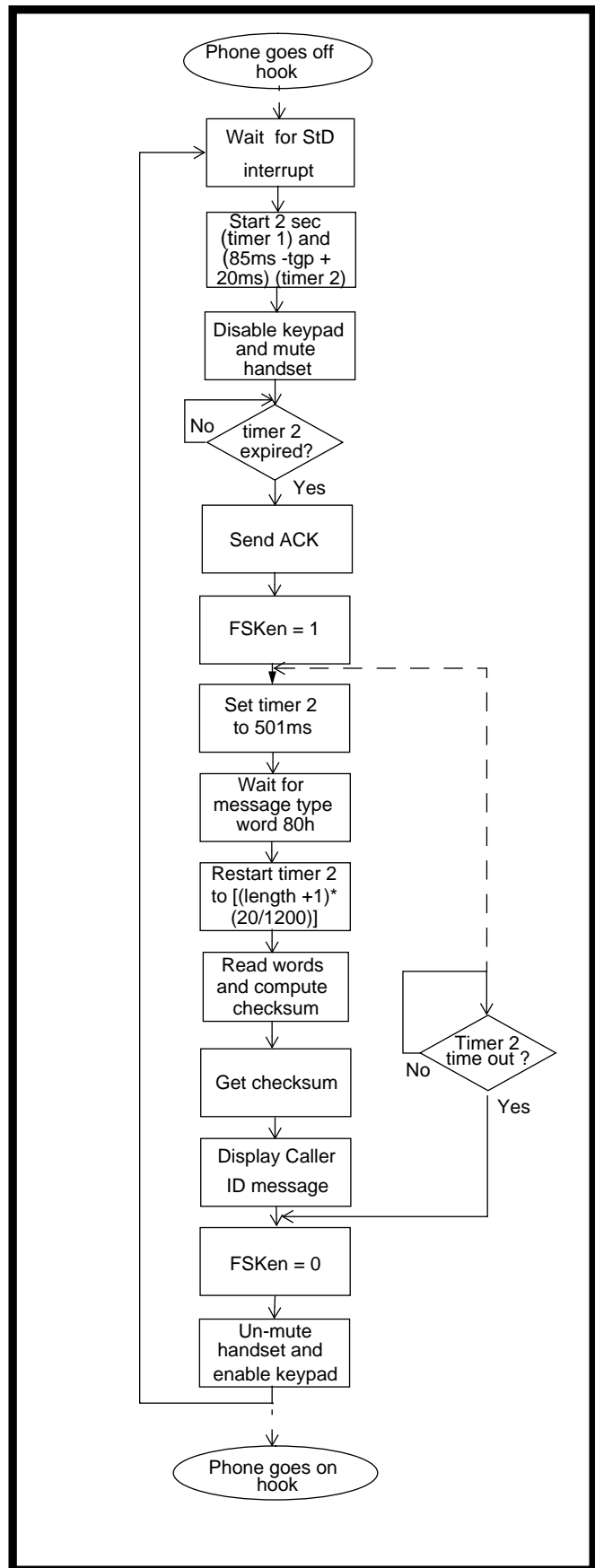

Figure 18 - Bellcore CIDCW Flowchart



The tasks are:

- A timer should be set to timeout at  $(85\text{ms} - t_{GP}) + 20\text{ms}$  to indicate the end of CAS (timer 2). At this time, also start a 2 second CAS ignore timer (timer 1). Further CAS should be processed only after the 2 second timer has timed out. Therefore before entering the CIDCW protocol service routine the software should verify that the 2 second timer has expired.
- At the end of CAS if no other CPE is off hook, mute the handset and disable the keypad. Send ACK. After ACK has been sent fully, enable FSK demodulation by setting the MT8843 FSKen pin. Timer 2 should be restarted to timeout in 501ms (time t in Figure 4).
- If message type word 80h has not been received when the 501ms timer expires, unmute speech path and enable keypad. Set FSKen=0. Exit service routine.
- After message type word 80h has been received, read the message length word. Restart the 501ms timer to

$$(\text{length} + 1) \times \frac{20\text{bits}}{1200\text{bps}}$$

The 20 bits come from 10 bits per word (start bit + byte + stop bit) and up to 10 mark bits stuffed between words.

- Read number of words specified by message length and calculate the checksum. Read transmitted checksum and add to calculated checksum. The sum should be 0.
- Set FSKen=0. Unmute handset and enable keypad.
- Display caller ID message and exit service routine.
- If a second CAS is detected while waiting for or during FSK, the detection is an imitation. Restart the 2 second CAS ignore timer.

The software can exit from the CIDCW program when the CPE has gone back on hook. In the service routine the CPE should only send ACK when no other CPE is off hook. One way is for the microcontroller to monitor the line voltage or current all the time, even when the CPE is on hook.

## Conclusion

The MT8843 can be used to extract caller ID information from BT, Bellcore, and CCA caller ID protocols. It contains a ringing and line reversal detector, CAS/Tone Alert Signal detector, and the ability to demodulate Bell 202 and CCITT V.23 FSK. Additionally it offers a high input sensitivity, a dual mode three-wire data interface, and an input gain adjustable amplifier.

The MT8843 can be used with relatively little associated circuitry to display the Caller ID information. It consumes very little power when powered down and can be used in battery powered applications without being a large power drain.

Notes:



**For more information about all Zarlink products  
visit our Web Site at  
[www.zarlink.com](http://www.zarlink.com)**

Information relating to products and services furnished herein by Zarlink Semiconductor Inc. trading as Zarlink Semiconductor or its subsidiaries (collectively "Zarlink") is believed to be reliable. However, Zarlink assumes no liability for errors that may appear in this publication, or for liability otherwise arising from the application or use of any such information, product or service or for any infringement of patents or other intellectual property rights owned by third parties which may result from such application or use. Neither the supply of such information or purchase of product or service conveys any license, either express or implied, under patents or other intellectual property rights owned by Zarlink or licensed from third parties by Zarlink, whatsoever. Purchasers of products are also hereby notified that the use of product in certain ways or in combination with Zarlink, or non-Zarlink furnished goods or services may infringe patents or other intellectual property rights owned by Zarlink.

This publication is issued to provide information only and (unless agreed by Zarlink in writing) may not be used, applied or reproduced for any purpose nor form part of any order or contract nor to be regarded as a representation relating to the products or services concerned. The products, their specifications, services and other information appearing in this publication are subject to change by Zarlink without notice. No warranty or guarantee express or implied is made regarding the capability, performance or suitability of any product or service. Information concerning possible methods of use is provided as a guide only and does not constitute any guarantee that such methods of use will be satisfactory in a specific piece of equipment. It is the user's responsibility to fully determine the performance and suitability of any equipment using such information and to ensure that any publication or data used is up to date and has not been superseded. Manufacturing does not necessarily include testing of all functions or parameters. These products are not suitable for use in any medical products whose failure to perform may result in significant injury or death to the user. All products and materials are sold and services provided subject to Zarlink's conditions of sale which are available on request.

Purchase of Zarlink's I<sup>2</sup>C components conveys a licence under the Philips I<sup>2</sup>C Patent rights to use these components in an I<sup>2</sup>C System, provided that the system conforms to the I<sup>2</sup>C Standard Specification as defined by Philips.

Zarlink and the Zarlink Semiconductor logo are trademarks of Zarlink Semiconductor Inc.

Copyright 2001, Zarlink Semiconductor Inc. All Rights Reserved.

TECHNICAL DOCUMENTATION - NOT FOR RESALE

---



**For more information about all Zarlink products  
visit our Web Site at  
[www.zarlink.com](http://www.zarlink.com)**

Information relating to products and services furnished herein by Zarlink Semiconductor Inc. or its subsidiaries (collectively "Zarlink") is believed to be reliable. However, Zarlink assumes no liability for errors that may appear in this publication, or for liability otherwise arising from the application or use of any such information, product or service or for any infringement of patents or other intellectual property rights owned by third parties which may result from such application or use. Neither the supply of such information or purchase of product or service conveys any license, either express or implied, under patents or other intellectual property rights owned by Zarlink or licensed from third parties by Zarlink, whatsoever. Purchasers of products are also hereby notified that the use of product in certain ways or in combination with Zarlink, or non-Zarlink furnished goods or services may infringe patents or other intellectual property rights owned by Zarlink.

This publication is issued to provide information only and (unless agreed by Zarlink in writing) may not be used, applied or reproduced for any purpose nor form part of any order or contract nor to be regarded as a representation relating to the products or services concerned. The products, their specifications, services and other information appearing in this publication are subject to change by Zarlink without notice. No warranty or guarantee express or implied is made regarding the capability, performance or suitability of any product or service. Information concerning possible methods of use is provided as a guide only and does not constitute any guarantee that such methods of use will be satisfactory in a specific piece of equipment. It is the user's responsibility to fully determine the performance and suitability of any equipment using such information and to ensure that any publication or data used is up to date and has not been superseded. Manufacturing does not necessarily include testing of all functions or parameters. These products are not suitable for use in any medical products whose failure to perform may result in significant injury or death to the user. All products and materials are sold and services provided subject to Zarlink's conditions of sale which are available on request.

Purchase of Zarlink's I<sup>2</sup>C components conveys a licence under the Philips I<sup>2</sup>C Patent rights to use these components in and I<sup>2</sup>C System, provided that the system conforms to the I<sup>2</sup>C Standard Specification as defined by Philips.

Zarlink, ZL and the Zarlink Semiconductor logo are trademarks of Zarlink Semiconductor Inc.

Copyright Zarlink Semiconductor Inc. All Rights Reserved.

**TECHNICAL DOCUMENTATION - NOT FOR RESALE**

---