

### SpaceWire IP Cores

STAR-Dundee offers essential SpaceWire network components as IP for use in FPGAs and ASICs. Our IP has proven to be robust and is widely used across the space industry, having been integrated into a number of flight FPGAs and flight ASICs.

Each of our SpaceWire IP cores has the following features:

- Highly configurable, giving flexibility through generics in the VHDL source.
- Low power, carefully designed to minimise switching frequencies and with a number of features including automatic power-down/power-up as required.
- Resilient to poorly conditioned SpaceWire signals, such as those with a high level of skew.
- Easily targeted for major FPGAs including radiation hard devices such as the Actel RTAX.

Currently STAR-Dundee offers two SpaceWire IP cores:

- SpaceWire Interface IP
- SpaceWire Router

The Interface IP provides a straightforward SpaceWire interface, the Router builds on the Interface IP providing the control of packets between ports.

#### SpaceWire Interface IP

The STAR-Dundee SpaceWire Interface IP provides a highly flexible interface to SpaceWire with the following features:

- Fully compliant with the SpaceWire standard.
- Low power by design.
- Configurable clocking schemes to meet the requirements of a wide range of applications.
- Robust against SpaceWire signals with a high level of skew or with poorly conditioned duty cycles.
- Simple data interface based on input and output FIFOs.
- Simple time-code interface.
- Status and error reporting.

#### Performance and Statistics

The approximate utilisation figures for a typical design with 32-byte transmit and receive FIFOs are given below.

	Actel RTAX1000	Actel RTAX2000	Xilinx Spartan 3E
<b>Interface IP</b>	7%	-	4%

#### Licensing

STAR-Dundee SpaceWire IP is available under license, provided as complete VHDL source code.

For more information on the IP cores, license, or if you have specific or custom requirements, please contact us.

### SpaceWire Router

The STAR-Dundee SpaceWire Router IP permits the creation of a flexible wormhole router based on a non-blocking crossbar switch. The router features:

- Fully compliant with the SpaceWire standard.
- Up to 31 SpaceWire ports.
- Up to 31 external parallel ports comprising an input FIFO and an output FIFO.
- A non-blocking crossbar-switch connecting any input port to any output port.
- Low power design with minimised, and configurable, switching frequencies.
- Ports can be set to start automatically when data is ready to send and stop when there is no data to send, to save power.
- An internal configuration port accessible via the crossbar switch from any SpaceWire or external parallel port.
- A routing table accessible via the configuration port which holds the logical address to output port mapping.
- Logic to control the operation of the switch, performing arbitration and group adaptive routing.
- A time-code interface and time-code generator able to generate time-codes at specified time intervals.
- Internal status/error registers accessible via the configuration port.

All communication with the configuration port is carried out using the standard Remote Memory Access Protocol (RMAP). The default configuration space is compatible with the SpW-10X ASIC available from Atmel (AT7910E), which contains our SpaceWire Router IP. A block diagram of the STAR-Dundee Router IP is shown below.

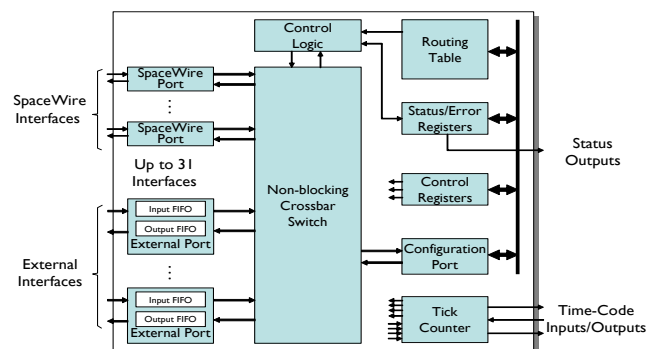

#### Performance and Statistics

The approximate utilisation figures for a typical router design with 4 SpaceWire ports and one external port are given below.

	Actel RTAX1000	Actel RTAX2000	Xilinx Spartan 3E
<b>Router</b>	-	50%	20%