



MAX24287 EV Kit

Evaluates: MAX24287

General Description

The MAX24287 EV Kit is an easy-to-use evaluation kit for the MAX24287 1Gbps Parallel-to-Serial MII Converter. On the network side of the MAX24287 an SFP module cage supports either a 1000BASE-X optical module or a module containing a 10/100/1000Mbps Ethernet PHY with an SGMII system interface. On the system side of the MAX24287 an unmanaged switch IC with integrated PHYs plus magnetics and RJ-45 jacks provides an easy Cat 5 Ethernet connection to test equipment.

An on-board 25MHz XO is provided to allow evaluation of device performance. Also, the board can accept an external oscillator input for testing alternate oscillators.

Typically the board is controlled by EV kit software running on a Windows PC through the USB interface. The board also has SPI and JTAG headers through which the MAX24287 can be controlled by a processor on another board as needed.

Demo Kit Contents

- ◆ MAX24287 Board
- ◆ Power Supply
- ◆ USB Cable

[Ordering Information](#) appears at end of data sheet.

Features

- ◆ Network-Side SFP Cage Accepts Optical or Electrical Ethernet SFP modules
- ◆ System-Side Unmanaged Ethernet Switch for Easy Connection to Lab Equipment.
- ◆ GPIO SMB Connectors to Input or Output Clock Signals and 1PPS Signals
- ◆ Connectors and Component Sites for Alternate Oscillators as Needed
- ◆ Included Universal 5V Power Supply
- ◆ Jumpers to Configure Reset State of MAX24287, GPIO Termination, Ethernet Switch Mode and More
- ◆ LEDs for Power Supplies Valid and Port Status
- ◆ Soldered MAX24287 for Best Signal Integrity
- ◆ Easy-to-Read Silkscreen Labels Identify the Signals Associated with All Connectors, Jumpers, and LEDs
- ◆ Windows®-Based Evaluation Software Provides Easy Configuration and Monitoring of the MAX24287 Device
- ◆ Evaluation Software Calls MAX24287 HAL Software and Structure is Similar to HAL Software

Minimum System Requirements

- ◆ PC Running Windows XP or later
- ◆ Available USB Port

Contents

1. Board Floorplan	4
2. Connections to the Board	5
2.1 Power-Supply Connection	5
2.2 USB Connection	5
2.3 Ethernet Connections and IP Addresses	5
2.4 Example Setup.....	5
3. Installing the Software	5
3.1 Troubleshooting Software Installation.....	5
4. Running the Software	6
5. Software User Interface.....	7
5.1 Status Display	7
5.2 Configuration Menu and Command Prompt	8
5.2.1 Navigating Menus and Changing Settings.....	8
5.2.2 Configuring the Device.....	8
5.2.3 Other Commands.....	8
5.3 Configuration Menu Detailed Descriptions	8
6. Jumpers, Connectors and LEDs.....	11
7. Component List	16
8. Schematics	18
9. Ordering Information.....	18
10. Revision History	18

List of Figures

Figure 1. MAX24287 EV Kit Board Floorplan	4
Figure 2. Example Setup	5
Figure 3. User Interface Main Screen	7

List of Tables

Table 1. Status Display Fields	7
Table 2. MAIN Menu	8
Table 3. CONFIG SCRIPTING Menu	9
Table 4. GPIO PINS Menu	9
Table 5. DATA PATH Menu.....	9
Table 6. TEST Menu.....	10
Table 7. Power and Reset Components.....	11
Table 8. MAX24287 REFCLK Jumpers and Connectors	11
Table 9. MAX24287 Pin Configuration Jumpers	12
Table 10. MAX24287 Parallel Interface Configuration	13
Table 11. MAX24287 GPIO1 Jumpers and Connectors	13
Table 12. MAX24287 GPIO2 Jumpers and Connectors	13
Table 13. MAX24287 GPIO3 Jumpers and Connectors	13
Table 14. Processor and Debug Jumpers and Connectors	14
Table 15. Ethernet Switch Jumpers, Connectors and LEDs	14
Table 16. SFP Module Jumpers and LEDs	15

1. Board Floorplan

When the board is oriented as shown in Figure 1, The 5V power supply and USB cable included with the kit are connected to jacks J1 and J2 at the top of the board. An SFP module is inserted into the SFP cage lower-left, and an appropriate cable is connected to the SFP module. The SFP module can be 1000BASE-X optical for a 1000Mbps optical connection, or it can contain a 10/100/1000Mbps copper PHY with an SGMII interface to the MAX24287 and an RJ-45 jack on the other side. The board ships with a 25MHz XO mounted in the Y1 oscillator. The Y2 and Y3 oscillator sites are primarily for the MAX24287 EV kit, which uses the same PCB. Other XOs can be mounted on daughter cards that plug in to connectors at the Y2 site. See section 6 for detailed descriptions of the board's jumpers, connectors and LEDs.

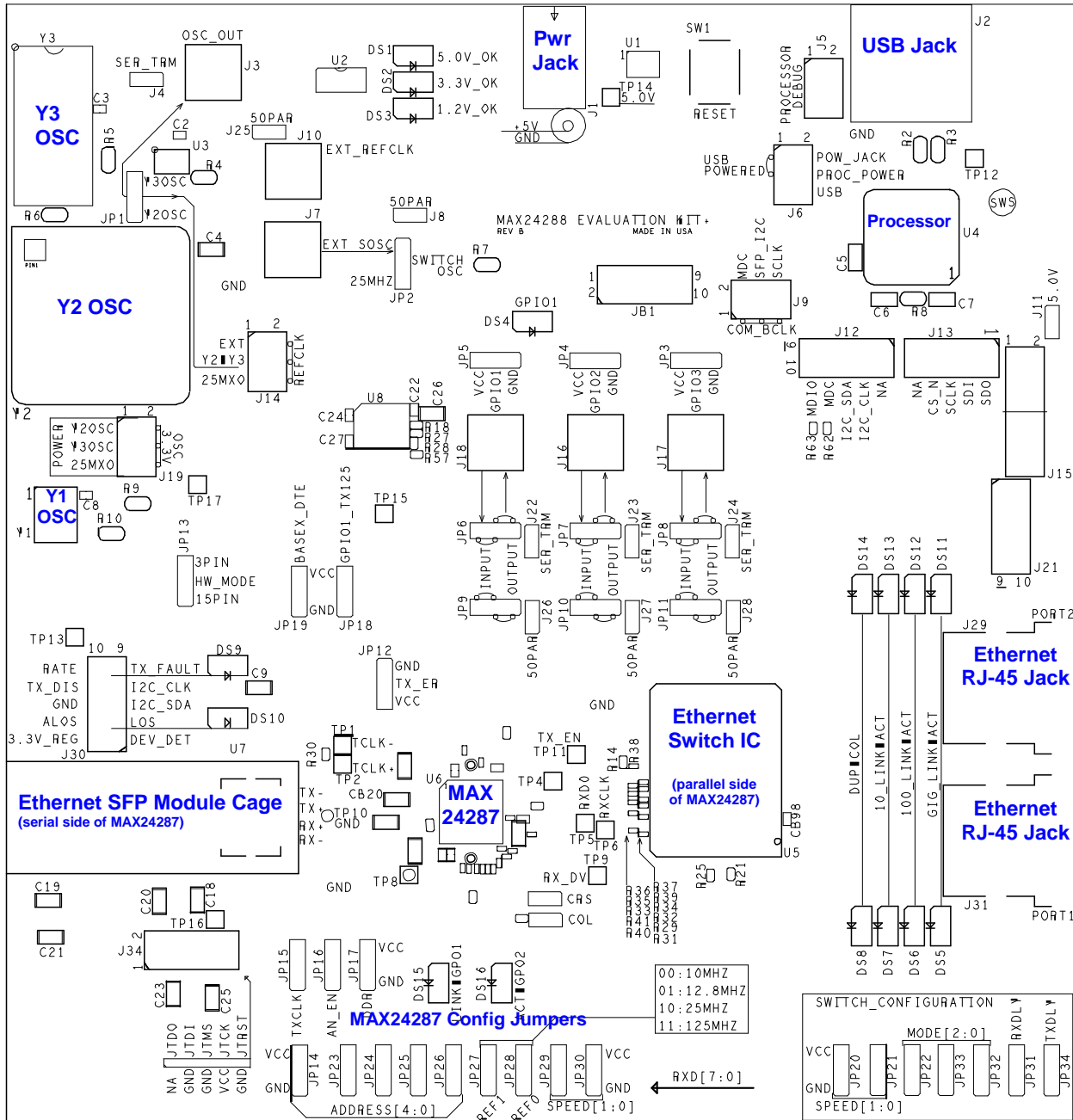

Figure 1. MAX24287 EV Kit Board Floorplan

2. Connections to the Board

2.1 Power-Supply Connection

The board is powered through connector J1 using the provided AC wall-plug 5V power supply. LED DS1 illuminates to indicate that the board is powered.

2.2 USB Connection

The MAX24287 EV kit software application communicates with the EV kit board through USB connector J2.

2.3 Ethernet Connections and IP Addresses

The Ethernet switch on the board, Realtek RTL8363, operates by default as a simple, unmanaged switch. To avoid set-up problems, each system connected to the MAX24287 EV Kit board must have a unique IP address.

2.4 Example Setup

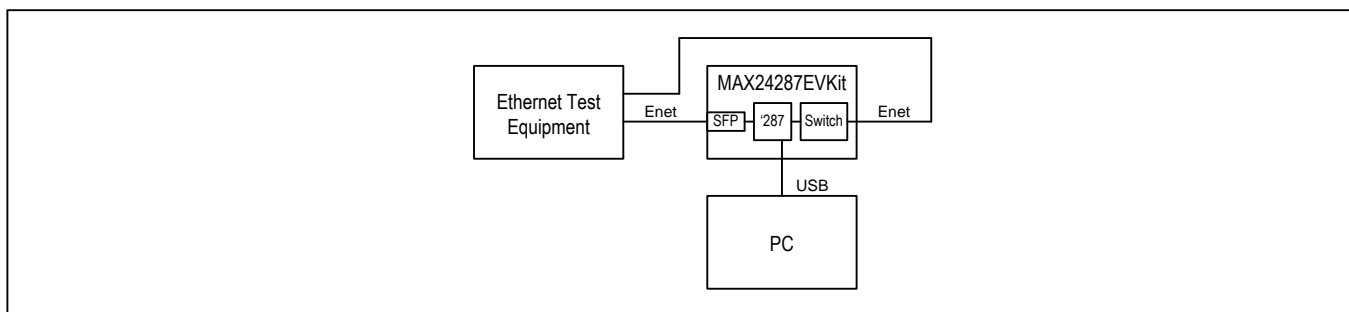

Figure 2. Example Setup

3. Installing the Software

Important Note: Do not connect the board to the PC until after installing the software. The device driver for the USB microcontroller will not be installed correctly.

Follow these steps to install the MAX24287 EV Kit software:

1. To install the software, run max24287evk.exe. The latest version of the EV Kit software can be downloaded from the Maxim website at www.maxim-ic.com/MAX24287EVKIT.
2. In the window that indicates the publisher could not be verified, click **Run**.
3. Follow the prompts in the MAX24287 Eval Kit setup wizard, For a default installation, click **Next** three times.
4. Connect the power cord to the J1 connector on the EV Kit board.
5. Connect a USB cable from a USB jack on the PC to the J2 connector on the EV Kit board.
6. In the notification area, Windows will indicate “Installing device driver” and then indicate “Freescale CDC Device (COM6) Device driver software installed successfully.”

The text “COM6” indicates the virtual COM port number assigned to the board. This number varies from system to system. Write down the assigned number to use when running the EV Kit software.

If Windows does not show the messages above then verify that the board is powered and is connected to the PC. If the board was already connected to the PC before installing the software then see follow the troubleshooting steps in section 3.1.

3.1 Troubleshooting Software Installation

If the board was connected to the PC before installing the software or if the EV kit software does not list the board’s COM port number as an option, then follow these steps:

1. In Windows, go to the Device Manager. In recent versions of Windows this is done by going to **Control Panel** and double-clicking **System**. Then in the upper-left corner click **Device Manager**.
2. In the Device Manager window, under **Other devices**, right-click on **Unknown device** and select **Uninstall**. In the **Confirm Device Uninstall** pop-up click **OK**.
3. In **Control Panel** double-click **Programs and Features**.
4. Right-click on **MAX24287 Eval Kit** and select **Uninstall**.
5. Disconnect power and USB cables from the EV Kit board.
6. Follow the steps in section [3](#).

4. Running the Software

To run the software, double-click on the **MAX24287 Eval Kit** shortcut on the desktop, or in the Windows Start menu, select **All Programs** → **Maxim** → **MAX24287 Eval Kit**.

At the prompt enter the COM port number assigned to the board in step 6 in section [3](#).

The software then displays its main menu, as shown in [Figure 3](#).

To start communication with the MAX24287 on the EV kit board, type **1** then **Enter** to create the MAX24287 HAL. If the software and the USB device driver have been installed correctly then regular screen updates begin.

If the software exits unexpectedly then run the software again and specify a different COM port number. If none of the listed COM port numbers is correct then follow the troubleshooting steps in section [3.1](#).

5. Software User Interface

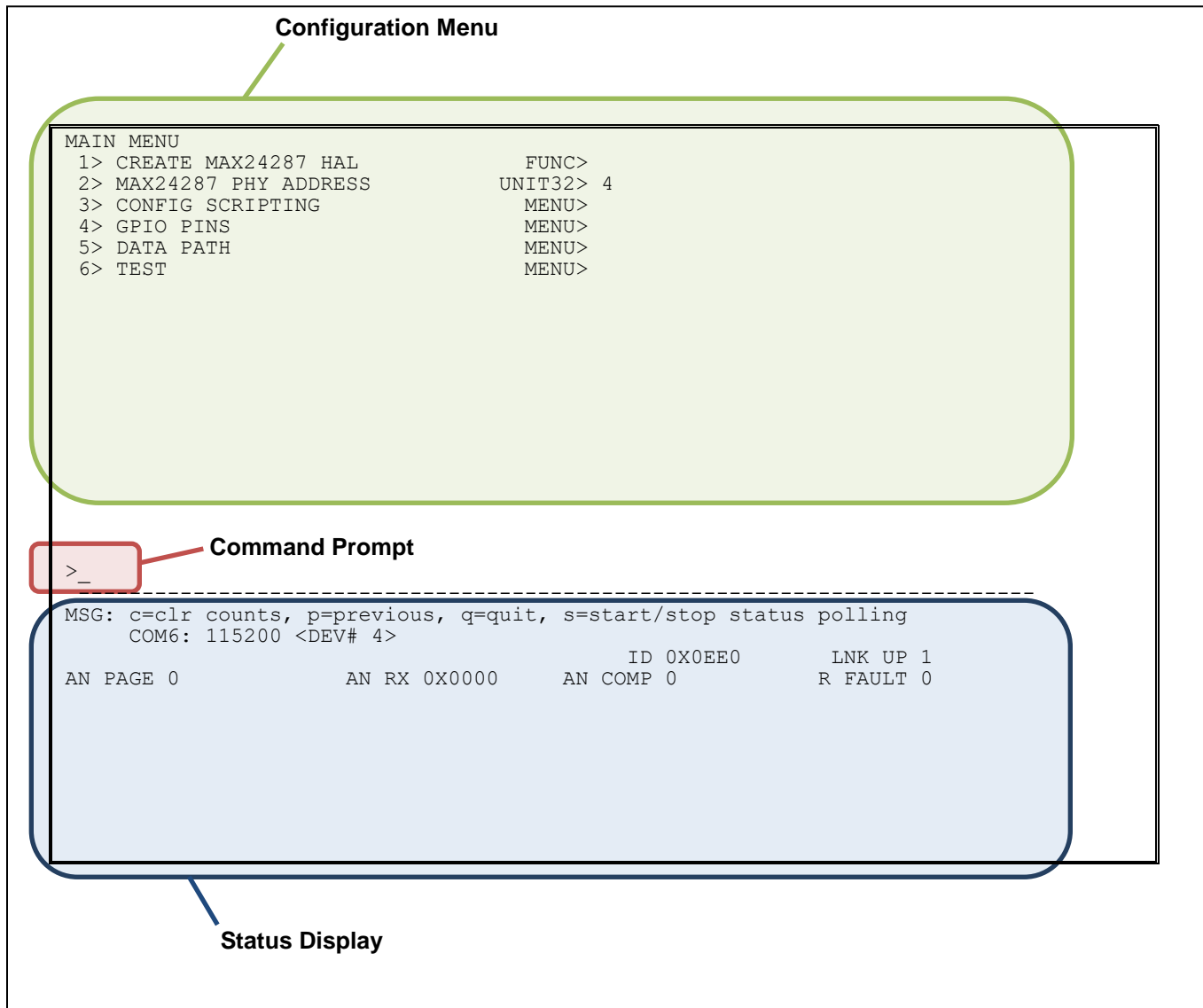

Figure 3. User Interface Main Screen

5.1 Status Display

The status display area (see the bottom of Figure 3) shows the latest data polled from the device. To start software polling and updating of these fields, select **CREATE MAX24287 HAL** in the main menu. To start or stop polling, use the **s** command at the command prompt. [Table 1](#) lists and describes the status display fields.

Table 1. Status Display Fields

Row	Field	Description
1	ID	Value read from the MAX24287 ID register
1	LNK UP	Link Up, MAX24287 BMSR register bit 2, 1=link up
2	AN PAGE	Auto-negotiation page available, 1=yes
2	AN RX	Auto-negotiation receiver register value
2	AN COMP	Auto-negotiation complete, MAX24287 BMSR register bit 5, 1=complete
2	R FAULT	Remote fault, MAX24287 BMSR register bit 4

5.2 Configuration Menu and Command Prompt

5.2.1 Navigating Menus and Changing Settings

Figure 3 shows the main screen of the MAX24287 software. In the upper half of the screen the command menu has two columns. The left-hand column shows numbered command/menu options. The right-hand column indicates what happens when an option is chosen. **FUNC>** indicates that a function is executed, **LIST>** indicates a list of choices will be presented, and **MENU>** indicates that the user will be taken to a submenu. Data types such as **UINT32>** or **STR>** indicate that a value with the specified data type can be entered. **UINT32>**, for example, means a 32-bit unsigned integer. **STR>** means text string.

To change the device configuration, the user types a number at the command prompt followed by the **Enter** key. If the option selected has a data type in the right-hand column, such as **UINT32>** then the cursor moves to the right of the data type. The user then enters the desired value followed by the **Enter** key. The cursor then moves back to the command prompt area.

If the option selected has **LIST>** in the right-hand column, then the cursor moves to the right of the **LIST>** text and a list of options is shown in an additional column on the right. The user then enters the option number from the list followed by the **Enter** key. The value next to **LIST>** then changes to the option selected, and the cursor moves back to the command prompt area.

5.2.2 Configuring the Device

All menus of the software are designed to have a two-step configuration process:

1. Configure the relevant values using data-type or **LIST>** menu options.
2. Configure the HAL or the device using a **FUNC>** menu option.

For example, in the **DATA PATH** menu, **AUTO-NEGOTIATE MODE** and **AUTO-NEGOTIATE ADVERT** are configure first, and then **CONFIG AUTO-NEGOTIATE** is selected.

5.2.3 Other Commands

In addition to menu item numbers, the following commands are also valid at the command prompt:

- c** – clear counts in status area
- p** – return to previous menu (when in a submenu)
- q** – quit the program
- s** – stop/start status polling

5.3 Configuration Menu Detailed Descriptions

Table 2. MAIN Menu

Name	Description
CREATE MAX24287 HAL	This function creates the MAX24287 HAL and starts polling device status. The three MAX24287* fields below must be set before this function is executed.
MAX24287 PHY ADDRESS	Specifies the address of the MAX24287 on the MDIO bus to the HAL. The MAX24287 gets its PHY address from pins RXD[7:4] and RX_ER when the MAX24287 RST_N pin is asserted.
CONFIG SCRIPTING	Opens the CONFIG SCRIPTING menu. See Table 3 .
GPIO PINS	Opens the GPIO PINS menu. See Table 4 .
DATA PATH	Opens the DATA PATH menu. See Table 5 .
TEST	Opens the TEST menu. See Table 6 .

Table 3. CONFIG SCRIPTING Menu

Name	Description
READ CONFIGURATION	Function reads configuration information from the file specified by the READ CONFIG FILE NAME parameter below.
WRITE CONFIGURATION	Function writes configuration information to the file specified by the WRITE CONFIG FILE NAME parameter below.
READ CONFIG FILE NAME	The file name for the READ CONFIGURATION function above. The file extension is .cfg.
WRITE CONFIG FILE NAME	The file name for the WRITE CONFIGURATION function above. The file extension is .cfg.

Table 4. GPIO PINS Menu

Name	Description
CONFIG GPIO	Function writes GPIO configuration from the fields below to MAX24287 register GPIOCR1 or GPIOCR2 for the pin(s) specified by GPIO CONFIG SELECT below.
GPIO CONFIG SELECT	Specifies one or all of {GPO1, GPO2, GPIO1-7} to be configured by the CONFIG GPIO function above.
GPOx MODE, GPIOx MODE (9 fields total)	Specify high-impedance, low, high, and several other options. Other options are pin-dependent and include: INT = interrupt output EXT CLK = Output the PTP_CLKO signal from the time engine REFCLK PLL 125 MHZ = Output 125MHz from the reference clock PLL RX 125/25 MHZ = Output clock from receive clock recovery PLL; the frequency is specified by GPIO RX PLL CLK MODE in the DATA PATH menu. RX 125/25 MHZ SQUELCH = same as RX 125/25 MHZ above and the output clock signal is squelched when certain receiver conditions occur such as LOS or ALOS LOS or ALOS = Output real-time link status, 1= link up CRS = Output carrier sense status See Table 6-4 through Table 6-6 in the MAX24287 data sheet. Note that GPIO4 through GPIO7 are the TXD4 through TXD7 pins, which are not available when the parallel MII interface is configured as GMII.

Table 5. DATA PATH Menu

Name	Description
CONFIG DATA PATH	Function writes configuration from fields LOOPBACK MODE through TXCLK PIN 125MHZ below to MAX24287 registers.
DEVICE DATA PATH MODE	Specifies the combination of serial interface type, parallel interface type and interface speeds. Examples include (1) GMII ↔SGMII (1000Mbps) and (2) RGMII10 ↔SGMII (10Mbps). <i>Affects MAX24287 register fields PCSCR.BASEX, GMIICR.SPD, GMIICR.DTE_DCE, and GMIICR.DDR.</i>
LOOPBACK MODE	Controls loopback modes. See the block diagram in the MAX24287 data sheet for loopback locations. <i>Affects register fields BMCR.DLB, PCSCR.TLB, GMIICR.RLB, CR.DLBDO, CR.RLBDO, CR.TLBDO.</i>
SERIAL TCLK PIN MODE	Enables/disables the TCLKP/N differential pair. <i>Affects register field CR.TCLK_EN.</i>
GPIO RX PLL CLK MODE	Specifies the frequency, 25MHz or 125MHz, of the receive recovered clock that can be output on GPIO pins. Also specifies whether this clock is squelched when any of several conditions occur, such as Rx loss of signal. <i>Affects register fields CR.RCFREQ and CR.RCSQL.</i>
TXCLK PIN 125MHZ	In GMII and RGMII modes, the TXCLK pin is not used for parallel interface operation. The TXCLK_EN bit enables TXCLK to output a 125MHz clock from the TX PLL in those modes. TXCLK_EN is ignored in MII mode. <i>Affects register field GMIICR.TXCLK_EN.</i>
CONFIG DIAG PATTERN	Function writes configuration from fields DIAGNOSTIC PATTERN MODE and CUSTOM 10-BIT PATTERN to MAX24287 registers.
DIAGNOSTIC PATTERN MODE	Specifies a diagnostic pattern transmit, typically for jitter testing. <i>Affects register fields JIT_DIAG.JIT_EN, JIT_DIAG.JIT_PAT.</i>
CUSTOM 10-BIT PATTERN	Specifies a custom 10-bit diagnostic pattern. <i>Affects register field JIT_DIAG.CUST_PAT.</i>
CONFIG AUTO-NEGOTIATE	Function writes configuration from AUTO-NEGOTIATE MODE and AUTO-NEGOTIATE ADVERT to MAX24287 registers.

Name	Description
AUTO-NEGOTIATE MODE	Enables/disables MAX24287 auto-negotiation. <i>Affects register fields BMCR.AN_EN and AN_START.</i>
AUTO-NEGOTIATE ADVERT	Specifies the auto-negotiation tx_Config_Reg[15:0] value for the MAX24287. <i>Affects register field AN_ADV.</i>

Table 6. TEST Menu

Name	Description
READ REGISTER	Function reads the register specified by the REGISTER ADDRESS fields below and displays the value in the REGISTER DATA fields below.
WRITE REGISTER	Functions writes the data value specified in the register data fields below into the register address specified by the REGISTER ADDRESS fields below.
REGISTER ACCESS MODE	Specifies the register access mode. MAX24287 USER MODE: The registers in Table 7-1 of the MAX24287 data sheet are at addresses 0-31 decimal, except that the page 1 (P1) registers are at 16 (decimal) + register number. For example, the ID register at P1.16 is at address 16+16=32 (decimal). MAX24287 MDIO: The MAX24287 registers are addressed using the MDIO addresses in Tables 7-1 and 7-2 of the MAX24287 data sheet. The page number must be manually set by writing the PAGESEL register at address 31 decimal. To use this mode polling must be stopped by entering s on the command line. This prevents the polling routine from changing the MDIO page in the PAGESEL register. SW PHY0 (MDIO#8): Accesses the registers of PHY0 on the evaluation board's switch chip. SW PHY1 (MDIO#9): Accesses the registers of PHY1 on the evaluation board's switch chip. SW MAC (MDIO#A): Accesses the MAC registers of the evaluation board's switch chip for the port connected to the MAX24287. SFP CFG (I2C#A0): Accesses the SFP module's internal EEPROM memory. SFP PHY (I2C#AC): Accesses the SFP module's PHY registers.
REGISTER ADDRESS HEX	Specifies the register address in hexadecimal for the READ REGISTER and WRITE REGISTER functions above. When REGISTER ADDRESS DEC below is changed, this field is changed to match. The REGISTER ACCESS MODE field above specifies the register mapping.
REGISTER ADDRESS DEC	Specifies the register address in decimal for the READ REGISTER and WRITE REGISTER functions above. When REGISTER ADDRESS HEX above is changed, this field is changed to match.
REGISTER DATA HEX	Indicates the data value in hexadecimal from the last time the READ REGISTER function was executed or the last time one of the REGISTER DATA fields was change by the user.
REGISTER DATA DECIMAL	Indicates the data value in decimal from the last time the READ REGISTER function was executed or the last time one of the REGISTER DATA fields was change by the user.
READ SFP MODULE INFO	Functions reads and displays the data from the evaluation board's SFP module. To end the data display and return to the menu, press the ENTER key.

6. Jumpers, Connectors and LEDs

Table 7. Power and Reset Components

COMPONENT	LABEL AND TYPE	BASIC SETTING	SCHEMATIC PAGE	DESCRIPTION
J1	5V jack	Connected	4	Power jack for 5V wall adapter (supplied)
DS1 DS2 DS3	5.0V_OK LED 3.3V_OK LED 1.2V_OK LED	On	4	Lit when power is within range for 5V, 3.3V, and 1.2V, respectively
SW1	DUT_RST button	Unused	5	Manual reset for entire system

Table 8. MAX24287 REFCLK Jumpers and Connectors

Note: MAX24287 is intolerant of REFCLK signal changes during operation. To make REFCLK signal changes, power down the board, change the jumpers as needed then apply power to the board again.

COMPONENT	LABEL AND TYPE	BASIC SETTING	SCHEMATIC PAGE	DESCRIPTION
JP1	Y2OSC / Y3OSC selection 3-pin header	Jumper connecting pins 2 and 3	7	Drives SMB connector J3 and jumper J14 pin 1. Connect the Y3OSC pin to the center pin to connect the Y3 oscillator output to J3 and J14. Connect the Y2OSC pin to the center pin to connect the Y2 oscillator output to J2 and J14.
J3	OSC_OUT SMB connector	Not monitored	7	J3 is driven by a buffer sourced by the center pin of JP1.
J4	SER_TRM 2-pin header	Not monitored	7	Install a jumper on J4 to apply 50 ohm parallel termination to J3
J10	EXT_REFCLK SMB connector	Not monitored	7	External REFCLK oscillator input. Signal goes to J14 pin 1.
J25	50PAR 2-pin header	Not monitored	7	Jumper J25 to apply 50 ohm parallel termination to J10.
J14	REFCLK 2x3pin header	Jumper connecting pins 5 and 6	7	Connects 25MHz XO clock or Y2/Y3 clock or external clock to MAX24287 REFCLK pin. Frequency must match the settings of the REF[1:0] jumpers (see Table 9). Connect pins 1 and 2 to select the external clock signal from SMB J10. Connect pins 3 and 4 to select the Y2 or Y3 clock signal from JP1. Connect pins 5 and 6 to select the Y1 clock signal.
J19	OSC 3.3V POWER 2x3pin header	All jumpered	7	Connect/disconnect 3.3V power for oscillator components Y1, Y2 and Y3. Connect pins 1 and 2 to power Y3. Connect pins 3 and 4 to power Y2. Connect pins 5 and 6 to power Y1. Note: the silkscreen mistakenly has Y2OSC and Y3OSC labels swapped.

Table 9. MAX24287 Pin Configuration Jumpers

COMPONENT	LABEL AND TYPE	BASIC SETTING	SCHEMATIC PAGE	DESCRIPTION
JP13	HW_MODE 3-pin header	Jumper in the 15PIN position.	3	MAX24287 COL pin. At reset this pin specifies 3-pin or 15-pin configuration mode.
JP15	TXCLK 3-pin header	Jumper in the GND position.	3	MAX24287 TXCLK pin. At reset the value on this pin is latched into the GMIICR.TXCLK_EN bit to configure TXCLK behavior. 0=high impedance. 1=125MHz from TX PLL. Ignored in MII mode.
JP16	AN_EN 3-pin header	Jumper in the GND position.	3	MAX24287 RX_DV pin. At reset the value on this pin is latched into the BMCR.AN_EN bit to configure auto-negotiation. 0=auto-negotiation disabled. 1=enabled.
JP17	DDR 3-pin header	Jumper in the GND position.	3	DDR: MAX24287 CRS pin.
JP29 JP30	SPEED[1:0] 3-pin header	JP29: VCC JP30: GND	3	SPEED[1:0]: MAX24287 RXD[1:0] pins. At reset the values on these pins are latched into the GMIICR.DDR and SPD[1:0] register bits. These jumpers together set the parallel interface mode for the MAX24287. See Table 10 for encodings. The equivalent interface configuration must be made on the Ethernet switch IC MODE and SPEED jumpers (see Table 15).
JP18	GPIO1_TX125 3-pin header	Jumper in the GND position.	3	MAX24287 GPO1 pin. At reset the value on this pin is latched into GPIOCR1.GPIO1_SEL[2] to configure GPIO1 behavior. 0=high impedance. 1=125MHz from TX PLL.
JP19	BASEX_DCE 3-pin header	Jumper in the GND position.	3	MAX24287 GPO2 pin. At reset the value on this pin is latched into GMIICR.DTE_DCE when SPEED[1:0] and DDR specify 10/100 MII mode or into PCSCR.BASEX when SPEED[1:0] and DDR specify some other mode. For 10/100 MII, 0=DCE, 1=DTE and the serial interface is configured for SGMII mode (PCSCR.BASEX=0). For other parallel interface modes, 0=SGMII, 1=BASEX.
JP14 JP23 JP24 JP25 JP26	ADDRESS[4:0] 3-pin headers	JP14: GND JP23: GND JP24: VCC JP25: GND JP26: GND	3	MAX24287 RX_ER and RXD[7:4] pins. At reset the values on these pins are latched into the internal MDIO PHY address register. Address 11111 enables factory test mode and should not be used. JP14 is RX_ER and ADDRESS[4]. JP23-JP26 are RXD[7:4] and ADDRESS[3:0].
JP27 JP28	REF[1:0] 3-pin headers	JP27: VCC JP28: GND	3	MAX24287 RXD[3:2] pins. At reset the values on these pins are latched into the internal REFCLK frequency register. 00=10MHz, 01=12.8MHz, 10=25MHz, 11=125MHz.
JP12	TX_ER 3-pin header	Jumper in the GND position.	3	MAX24287 TX_ERR pin.

COMPONENT	LABEL AND TYPE	BASIC SETTING	SCHEMATIC PAGE	DESCRIPTION
TP1 TP2	TP1, TP2 Test points	Not used	1	Test points for TCLKN (TP1) and TCLKP (TP2)
TX- TX+ RX+ RX- TP10	TX-, TX+, RX+, RX-, TP10 Test points	Not used	NA	Unconnected copper shapes have been placed next to each trace, and a section of the trace metal is exposed. A solder bridge may be used to bridge the trace to the shape, creating a test point.

Table 10. MAX24287 Parallel Interface Configuration

SPEED[1]	SPEED[0]	Speed	DDR=0	DDR=1
0	0	10Mbps	MII	RGMI-10
0	1	100Mbps	MII	RGMI-100
1	0	1000Mbps	GMI	RGMI-1000
1	1	1000Mbps	TBI	RTBI

Table 11. MAX24287 GPIO1 Jumpers and Connectors

COMPONENT	LABEL AND TYPE	BASIC SETTING	SCHEMATIC PAGE	DESCRIPTION
J18	SMB Connector	Not jumpered	3	I/O connector for GPIO1.
JP5	GPIO1 3-pin header	Not jumpered	3	Can be used to bias GPIO1 high or low.
JP6 and JP9	3-pin headers	Not jumpered	3	To drive a signal from SMB J18 to GPIO1, jumper JP6 pins 2 and 3 and JP9 pins 2 and 3. To drive a signal from GPIO1 to SMB J18, jumper JP6 pins 1 and 2 and JP9 pins 1 and 2.
J22	2-pin header	Not jumpered	3	Install J22 to short the 30 ohm series termination at JP6 pin 2.
J26	2-pin header	Not jumpered	3	Install J26 to apply 50 ohm parallel termination to JP9 pin 2
DS4	LED	Off	3	Lit when GPIO1 is high.

Table 12. MAX24287 GPIO2 Jumpers and Connectors

COMPONENT	LABEL AND TYPE	BASIC SETTING	SCHEMATIC PAGE	DESCRIPTION
J16	SMB Connector	Not jumpered	3	I/O connector for GPIO2.
JP4	GPIO1 3-pin header	Not jumpered	3	Can be used to bias GPIO2 high or low.
JP7 and JP10	3-pin headers	Not jumpered	3	To drive a signal from SMB J16 to GPIO2, jumper JP7 pins 2 and 3 and JP10 pins 2 and 3. To drive a signal from GPIO1 to SMB J16, jumper JP7 pins 1 and 2 and JP10 pins 1 and 2.
J23	2-pin header	Not jumpered	3	Install J23 to short the 30 ohm series termination at JP7 pin 2.
J27	2-pin header	Not jumpered	3	Install J27 to apply 50 ohm parallel termination to JP10 pin 2

Table 13. MAX24287 GPIO3 Jumpers and Connectors

COMPONENT	LABEL AND TYPE	BASIC SETTING	SCHEMATIC PAGE	DESCRIPTION
J17	SMB Connector	Not jumpered	3	I/O connector for GPIO3.
JP3	GPIO1 3-pin header	Not jumpered	3	Can be used to bias GPIO3 high or low.
JP8 and JP11	3-pin headers	Not jumpered	3	To drive a signal from SMB J17 to GPIO3, jumper JP8 pins 2 and 3 and JP11 pins 2 and 3. To drive a signal from GPIO1 to SMB J17, jumper JP8 pins 1 and 2 and JP11 pins 1 and 2.

COMPONENT	LABEL AND TYPE	BASIC SETTING	SCHEMATIC PAGE	DESCRIPTION
J24	2-pin header	Not jumpered	3	Install J24 to short the 30 ohm series termination at JP8.2.
J28	2-pin header	Not jumpered	3	Install J28 to apply 50 ohm parallel termination to JP11.2

Table 14. Processor and Debug Jumpers and Connectors

COMPONENT	LABEL AND TYPE	BASIC SETTING	SCHEMATIC PAGE	DESCRIPTION
J2 (USB)	USB jack	Connected	8	USB connector, attach to PC with supplied cable
J5	PROCESSOR DEBUG 2x3pin header	Not Connected	8	BDM connector for use with debug pod
J9	COM_BCLK 2x3pin header	Not jumpered	5	Used to make a common communication clock. Jumper options allow to short MDC, I2C_CLK and SPI clock.
J12	2x5pin header	Jumpered 3-4, 5-6, 7-8, 9-10	5	Connection points for processor pins to SFP I2C and MAX24287 MDIO. Disconnect if connecting an external processor.
J13	2x5pin header	Jumpered 1-2, 3-4, 5-6, 7-8	5	Connection points for processor pins to MAX24287 SPI. Disconnect if connecting an external processor.
J15	2x7 header	Not used	5	Connection for external processor board
J21	2x5 header	Not used	5	SPI bus connection to external board such as Maxim's DS31400DK.
J11	2-pin header	Not used	5	Place a jumper to connect 5V to J15 pin 2.
J34	2x5pin header	Jumpered 9-10	5	MAX24287 JTAG header. When not in JTAG mode the JTRST pin should be driven low by connecting pins 9 and 10.
JB1	2x5 header (just below the Maxim logo)	Not jumpered	8	Connects to several GPIO on the processor to provide for future board application options.

Table 15. Ethernet Switch Jumpers, Connectors and LEDs

COMPONENT	LABEL AND TYPE	BASIC SETTING	SCHEMATIC PAGE	DESCRIPTION
JP2	SWITCH OSC 3-pin header	Jumper in the 25MHZ position.	7	Selects clock signal applied to the RTL8363 switch XTAL1 pin. Connect center pin to 25MHZ pin to select the clock signal from Y1. Connect center pin to EXT_SOSC to select the clock signal from SMB J7.
J7	EXT_SOSC SMB connector	Not Driven	7	External clock for Ethernet switch IC. JP2 must have jumper in the EXT_SOSC position to use this signal.
J8	50PAR 2-pin header	Not jumpered	7	Install jumper to apply 50 ohm parallel termination to the signal on J7.
JP20 JP21	SPEED[1:0] 3-pin headers	JP20: GND JP21: VCC	11	Switch-IC P2SPD[1:0] pins. Selects speed of MII interface to MAX24287. The equivalent interface configuration must be made on the MAX24287 SPEED jumpers (see Table 9). 00: 10M 01: 100M 10: 1000M

COMPONENT	LABEL AND TYPE	BASIC SETTING	SCHEMATIC PAGE	DESCRIPTION
JP22 JP33 JP32	MODE[2:0] 3-pin headers	JP22: GND JP33: GND JP32: GND	11	Switch-IC P2IF[2:0] pins. Selects mode of MII interface to MAX24287. The equivalent interface configuration must be made on the MAX24287 DDR and BASEX_DCE jumpers (see Table 9). 000: GMII/PHY MODE MII 001: GMII/MAC MODE MII 010: RGMII 011: RMII (do not use, not compatible with MAX24287)
JP31	RXDLY 3-pin header	Jumper in the VCC position.	11	Switch-IC RXDLY pin, adds delay to RX CLK between MAX24287 and switch IC. Jumper to VCC to add 1.5nsec delay Jumper to GND to add 0 delay
JP34	TXDLY 3-pin header	Jumper in the VCC position.	11	Switch-IC TXDLY pin, adds delay to TX CLK between MAX24287 and switch IC. Jumper to VCC to add 1.5nsec delay Jumper to GND to add 0 delay
J29	PORT1 RJ-45 jack	Not Connected	10	Interface to Port 1 of Ethernet Switch IC
J31	PORT0 RJ-45 jack	Connected	10	Interface to Port 0 of Ethernet Switch IC
DS14	DUP / COL LED	--	10	Port 1 status LEDs, indicate link status and speed.
DS13	10_LINK/ACT LED	--	10	
DS12	100_LINK/ACT LED	--	10	
DS11	GIG_LIN/ACT LED	--	10	
DS8	DUP / COL LED	--	10	Port 0 status LEDs, indicate link status and speed.
DS7	10_LINK/ACT LED	--	10	
DS6	100_LINK/ACT LED	--	10	
DS5	GIG_LIN/ACT LED	--	10	

Table 16. SFP Module Jumpers and LEDs

COMPONENT	LABEL AND TYPE	BASIC SETTING	SCHEMATIC PAGE	DESCRIPTION
J30	2x5pin header	Jumpered 6-8 Jumpered 3-4	6	SFP test points and bias points A jumper connecting pins 6 and 8 enables TX. A jumper connecting pins 3 and 4 connects SFP_LOS signal to MAX24287 ALOS pin.
DS9	TX_FAULT LED	--	6	Indicates SFP module transmit fault signal is active.
DS10	LOS LED	--	6	Indicates SFP module LOS signal is active.

7. Component List

DESIGNATION	QTY	DESCRIPTION	SUPPLIER	PART
Reference designators shown on next row (C1, ..., CB143)	81	0402 CERAM 1uF 10V	TDK	C1005X5R1A105M
C1, C2, C12, C13, C14, C22, C27, CB8, CB10, CB13, CB14, CB21, CB23, CB25, CB28, CB30, CB31, CB34, CB35, CB36, CB37, CB38, CB39, CB40, CB41, CB42, CB45, CB49, CB50, CB51, CB52, CB53, CB54, CB55, CB57, CB58, CB62, CB64, CB66, CB67, CB69, CB70, CB71, CB73, CB74, CB76, CB77, CB79, CB81, CB84, CB86, CB87, CB89, CB91, CB92, CB94, CB95, CB98, CB99, CB100, CB102, CB104, CB106, CB107, CB113, CB115, CB116, CB119, CB121, CB122, CB123, CB124, CB127, CB128, CB129, CB133, CB134, CB135, CB141, CB142, CB143				
Reference designators shown on next row (C3, ..., CB145)	41	0402 CERAM 0.01uF 16V 10%	Panasonic	ECJ-0EB1C103K
C3, C8, C10, C17, C24, CB3, CB7, CB12, CB26, CB27, CB47, CB59, CB60, CB61, CB63, CB65, CB68, CB72, CB75, CB78, CB80, CB82, CB83, CB85, CB88, CB90, CB93, CB96, CB97, CB101, CB103, CB105, CB108, CB109, CB110, CB111, CB114, CB117, CB118, CB120, CB145				
C4, C9, C11, C15, C16, C18, C19, C20, C21, C23, C25, C26, CB1, CB2, CB4, CB5, CB9, CB11, CB15, CB19, CB20, CB24, CB29, CB32, CB33, CB44, CB46, CB56, CB112, CB125, CB130, CB131, CB132, CB139, CB140, CB146	36	0603 CERAM 10uF 6.3V 20% MULTILAYER	Panasonic	ECJ-1VB0J106M
C5, CB18	2	0603 CERAM .1uF 16V 20% X7R	AVX	0603YC104MAT
C6, C7	2	0603 CERAM 22pF 25V 5% NPO	AVX	06033A220JAT
CB17, CB22	2	0603 CERAM 4.7uF 6.3V MULTILAYER	UNK	ECJ-1VB0J475M
CB43, CB48, CB126, CB136, CB137, CB138	6	CAP CER 3.3UF 4.0V X5R 0402	AMK	AMK105BJ335MV-F
CB6, CB16, CB144	3	D CASE TANT 470uF 6.3V 20%	KEM	T491D477M006AS
DB1	1	SCHOTTKY DIODE, 1 AMP 40 VOLT	International Rectifier	10BQ040
DS1, DS2, DS3, DS5, DS6, DS7, DS8, DS11, DS12, DS13, DS14	11	LED, GREEN, SMD	Panasonic	LN1351C
DS4, DS15, DS16	3	LED, GREEN, SMD	Panasonic	LN1351C
DS9, DS10	2	LED, RED, SMD	Panasonic	LN1251C
GND_TP1, GND_TP2, GND_TP3, GND_TP4	4	STANDARD GROUND CLIP	KEYSTONE	4954
J1	1	2.0MM SURFACE MOUNT POWER JACK	CUI INC	PJ-002AH-SMT
J11	1	2 PIN HEADER, .100 CENTERS, VERTICAL	Samtec	TSW-102-07-T-S
J12, J13, J30, J34	4	TERMINAL STRIP, 10 PIN, DUAL ROW, VERT	DIG	S2012-05-ND
J15	1	HEADER, 14 PIN, DUAL ROW, VERT NOT POPULATED	Samtec	HDR-TSW-107-14-T-D
J2	1	TYPE B SINGLE RT ANGLE, BLACK	MOL	NA
J29, J31	2	CONNECTOR, SINGLE LEVEL, GIGABIT RJ-45, 10 PIN WITH LED	Halo Electronics	HFJ11_1G41E_L12RL
J3, J7, J10, J16, J17, J18	6	CONNECTOR, SMB, 50 OHM VERTICAL, 5PIN	AMP	413990-1
J4, J8, J22, J23, J24, J25, J26, J27, J28, J32, J33	11	100 MIL 2 POS JUMPER	NA	NA
J5, J6, J9, J14, J19	5	TERMINAL STRIP, 6 PIN, DUAL ROW, VERT	Samtec	TSW-103-07-T-D
JB1 J15, J21	3	TERMINAL STRIP, 10 PIN, DUAL ROW, VERT DO NOT POPULATE	DNP	DNP

DESIGNATION	QTY	DESCRIPTION	SUPPLIER	PART
JP1, JP2, JP3, JP4, JP5, JP6, JP7, JP8, JP9, JP10, JP11, JP12, JP13, JP14, JP15, JP16, JP17, JP18, JP19, JP20, JP21, JP22, JP23, JP24, JP25, JP26, JP27, JP28, JP29, JP30, JP31, JP32, JP33, JP34	34	100 MIL 3 POS JUMPER	NA	NA
LB1, LB3, LB4, LB9, LB10, LB11, LB12, LB13, LB14	9	FERRITE 3A 100 OHM AT 100 MHZ 1206 SMD	Steward	HI1206N101R-00
LB5, LB6, LB7, LB8	4	1uH ±10% 0805 Multilayer Ceramic 400 mA (ok to sub with 445-3156-1-ND)	Murata	LQM21FN1R0N00D
R1, R4, R5, R6, R7, R9, R10, RB5	9	RES 0603 30 Ohm 1/16W	Panasonic	ERJ-3GEYJ300V
R11, R18, R19, R21, R57, RB8, RB3	4	RES 0402 0 OHM 1/10W 5%	Panasonic	ERJ-2GE0R00X
R12, R17, R20, R22, R23, R29, R31, R32, R33, R34, R35, R36, R37, R38, R39, R40, R41, R42, R43, R44, R45, R46, R47, R48, R49, R50, R51, R52, R53, R54, R55, R56	32	RES 0201 30.0 OHM 1/16W 1%	Panasonic	ERJ-1GEJ300C
R13, R14, R25, R26, RB23, RB24, RB25, RB38, RB44, RB45, RB49, RB50, RB51, RB52, RB53, RB54, RB56, RB57, RB63, RB64, RB69, RB71, RB72, RB73, RB77, RB78, RB79, RB80, RB81, RB86, RB87,	31	RES 0402 10.0 KOHM 1/16W 1%	Panasonic	ERJ-2RKF1002X
R16, RB27, RB28, RB29	4	RES 0402 30.0 OHM 1/16W 1%	Panasonic	ERJ-2RKF30R0X
R30, R15	2	RES 0402 100 OHM 1/16W 1%	Panasonic	ERJ-2RKF1000X
R2, R3	2	RES 0603 33.2 Ohm 1/16W 1%	Panasonic	ERJ-3EKF33R2V
R24, R28, R62, R63, RB13, RB15, RB16, RB17, RB18, RB19, RB20, RB21, RB22, RB26, RB39, RB40, RB41, RB42, RB43, RB82	18	RES 0402 1.00 KOHM 1/16W 1%	Panasonic	ERJ-2RKF1001X
R27	1	RES 0402 1.40 KOHM 1/16W 1%	Panasonic	ERJ-2RKF1401X
R8	1	RES 0603 1.00M Ohm 1/16W 1%	Panasonic	ERJ-3EKF1004V
RB1, RB4, RB9, RB30, RB31, RB32, RB33, RB34, RB60, RN1	11	RES 0603 1.0K Ohm 1/16W 5%	Panasonic	ERJ-3GEYJ102V
RB14, RB84, RB85, R60	5	RES 0603 330 Ohm 1/16W 5%	Panasonic	ERJ-3GEYJ331V
RB2, RB11, RB35, RB36, RB37	5	RES 0402 49.9 OHM 1/16W 1%	Panasonic	ERJ-2RKF49R9X
RB6, RB10, RB83	3	RES 0603 10K Ohm 1/16W 5%	Panasonic	ERJ-3GEYJ103V
RB65	1	RES 0603 2.49K Ohm 1/16W 1%	Panasonic	ERJ-3EKF2491V
RB7	1	RES 0603 10.0K Ohm 1/16W 1%	Panasonic	ERJ-3EKF1002V
RPB5, RPB6, RPB7, RPB9, RPB13	6	RESISTOR, 4 PACK, 330 OHM 5PCT QUAD 0603	Panasonic	EXB-V8V331JX
RPB10, RPB11	2	RESISTOR, 4 PACK, 10K OHM 5PCT QUAD 0603	Panasonic	EXB-V8V103JX
RPB2, RPB3, RPB4	3	RESISTOR, 4 PACK, 33 OHM 5PCT QUAD 0603	Panasonic	EXB-V8V330JV
RPB8, RPB12	2	RESISTOR, 4 PACK, 4.7K OHM 5PCT QUAD 0603	Panasonic	EXB-V8V472JX
SW1	1	SWITCH MOM 4PIN SINGLE POLE	Panasonic	EVQPAE04M
TP1, TP2, TP3, TP4, TP5, TP6, TP7, TP8, TP9, TP10, TP11, TP12, TP13, TP15, TP16, TP17, TPB1, TPB2, TPB3, TPB4, TPB5, TPB6, TPB7, TPB8, TPB9, TPB10	26	TESTPOINT, 1 PLATED HOLE, DO NOT STUFF	NA	NA
U1	1	MICROPROCESSOR VOLTAGE MONITOR, 3.08V RESET, 4PIN SOT143	Maxim	MAX811TEUS-T
U2	1	VOLTAGE MONITOR 5, 3.3, 2.5, ADJ	Maxim	MAX6709AUB+

DESIGNATION	QTY	DESCRIPTION	SUPPLIER	PART
UB3,UB4,UB5,UB6,UB9,UB10,UB11,UB12,UB13,UB14,UB15,UB16,UB19,UB20	14	HIGH SPEED BUFFER	FAIRCHILD	NC7SZ86
U4	1	IC, HCS08 8-BIT MICROCONTROLLER, 32K FLASH, 2K RAM, 2 UART, 2 SPI, I2C, USB, -40 TO 85C, 64 PIN LQFP	FREESCALE	MC9S08JM32CLH-ND
U5	1	RTL8363 PHY	REALTEK	RTL8363C
U6	1	MAX24287 QFN 8X8	MAXIM	MAX24287ETK+
U7	1	SFP host / receptacle	PARTS_KIT	SFP_HOST-TYCO
U8	1	IC, LINEAR REG ADJ, 2A, 14TSSOP-EP	MAXIM	MAX8526EUD+
UB2, UB7, UB17, UB18, UB21	5	IC, LINEAR REGULATOR, 1.5W, 3.3V OR ADJ, 1A, 16 PIN TSSOP-EP	Maxim	MAX1793EUE-33
XB1	1	XTAL, HC49SD, 12.0000MHz +/-50PPM, CL=20PF	FOX	FOXSDLF-120-20
Y1	1	OSCILLATOR LVCMOS, 3.3V, 25 MHZ, 4 PIN SMD	Connor-Winfield	MX010-025.0M
Y2	1	OSCILLATOR, VECTRON OCXO, 3.3V, 12.8 MHZ, 5 PIN THROUGH-HOLE	VEC	MC853X4-035W NOT POPULATED
Y3	1	OSCILLATOR, RAKON TC-OCXO, 3.3V, 10MHZ RFPO-30-RX-C-LF	RAKON	P5299LF NOT POPULATED
J9	1	TERMINAL STRIP, 6 PIN, DUAL ROW, VERT NOT POPULATED	Samtec	TSW-103-07-T-D NOT POPULATED
TP14	1	TESTPOINT, 1 PLATED HOLE RED	KEYSTONE	5000R
U3,UB1,UB8	3	TINYLOGIC HIGH SPEED 2-INPUT AND GATE, 5 PIN SOT23	Fairchild	NC7SZ08M5

8. Schematics

The schematics are shown in the following pages.

9. Ordering Information

PART	TYPE
MAX24287EVKIT	Evaluation Kit

10. Revision History

REVISION DATE	DESCRIPTION
10/11	Initial Release
2012-05	Reformatted for Microsemi. No content change.