



TX-500

**Features**

- Low Phase Noise
- Low power consumption
- Output: HCMOS, Clipped Sinewave, PECL, True Sinewave
- Tight Tolerances
- Frequency range <sup>1</sup> of 6.4 - 160 MHz
- Standard Frequencies : 10, 12.8, 16.384, 19.44, 19.2, 20, 26 50, 77.76, 100, 122.88, 125, 155.52 MHz

**Applications**

- Base Station
- Test Equipment
- Communication Equipment
- Digital Switching
- Military

**Performance Specifications**

**Frequency Stabilities<sup>1</sup> (Standard TCXO)**

Parameter	Min	Typical	Max	Units	Condition	Options <sup>3</sup>
vs. operating temperature range (referenced to +25°C)	-1		+1	ppm	-40 to +85°C	
	-0.5		+0.5	ppm	-40 to +85°C	
	-1		+1	ppm	-20 to +70°C	
	-0.28		-0.28	ppm	-20 to +70°C	
Initial tolerance	-1		+1	ppm	at time of shipment, nominal EFC	
vs. supply voltage change	-0.2		+0.2	ppm	V <sub>S</sub> ±5% static	
vs. load change	-0.1		+0.1	ppm	Load ±10% static	
vs. aging / year	-1		+1	ppm	after 30 days of operation	

**Frequency Stabilities<sup>1</sup> (Stratum 3 TCXO)**

Parameter	Min	Typical	Max	Units	Condition	Options <sup>3</sup>
vs. operating temperature range (referenced to +25°C)	-0.8		+0.8	ppm	-40 to +85°C	
	-0.28		+0.28	ppm	-40 to +85°C	
	-0.8		+0.8	ppm	-20 to +70°C	
	-0.28		-0.28	ppm	-20 to +70°C	
Initial tolerance	-1		+1	ppm	at time of shipment, nominal EFC	
vs. supply voltage change	-0.2		+0.2	ppm	V <sub>S</sub> ±5% static	
vs. load change	-0.1		+0.1	ppm	Load ±10% static	
vs. aging / year	-1		+1	ppm	after 30 days of operation	
vs. aging / 20 years	-2.5		+2.5	ppm		Note: Stratum 3 per GR-1244-CORE: <±4.6ppm for all causes and 20years aging Holdover: <±0.37ppm over 24 hours
Over all tolerance	-4.6		+4.6	ppm		

## Performance Specifications

Supply Voltage (Vs)						
Parameter	Min	Typical	Max	Units	Condition	
Supply voltage (standard)	3.135	3.3	3.465	VDC		
Supply voltage (Option)	4.75	5	5.25	VDC		
Current consumption			35 100	mA mA	steady state @25°C, HCMOS, Clipped sinewave steady state @25°C, PECL	
RF Output						
Signal [standard]	HCMOS					
Load	13.5	15	16.5	pF		
Signal Level (Vol)			0.3	VDC	with Vs=3.3V and 15pF Load	
Signal Level (Voh)	2.6				with Vs=3.3V and 15pF Load	
Duty Cycle	40		60	%	@ (Voh-Vol)/2	
Rise and Fall time			5	ns	@15 pF 10 to 90 %	
Signal [Option]	Clipped Sinewave				Available < 40MHz only	
Load R	9	10	11	kOhm		
Load // C	9	10	11	pF		
Output power	0.7			V <sub>pp</sub>	@ 10kOhm // 10pF	
Signal [Option]	PECL				Available > 40MHz only	
Load	45	50	55	Ohm	to Vs - 2V	
Rise and Fall time			1	ns	20 to 80%	
Duty Cycle	45		55	%		
Signal [Option]	True Sinewave					
Load	45	50	55	Ohm		
Output power	0	3	6	dBm		
Frequency Tuning (EFC) 6.4 to 26 MHz						
Tuning Range	Fixed TCXO; No adjust				Option <sup>5</sup>	
Tuning Range	±8 ±5			ppm ppm		
Linearity	<10%					
Tuning Slope	Positive					
Control Input Impedance	10			kOhm		
Control Voltage Range	0.3	1.65	3.0	VDC	with Vs=3.3V	
Additional Parameters						
Phase Noise <sup>2</sup>		-87		dBc/Hz	10 Hz	@ 12.8 MHz HCMOS 3.3 V
		-119		dBc/Hz	100 Hz	
		-138		dBc/Hz	1 kHz	
		-151		dBc/Hz	10 kHz	
		-155		dBc/Hz	100 kHz	
		-155		dBc/Hz	1 MHz	
Jitter		0.2		ps RMS	@ 12 kHz to 20 MHz	
Phase Noise		-73		dBc/Hz	10 Hz	@ 100MHz HCMOS 3.3V
		-102		dBc/Hz	100 Hz	
		-132		dBc/Hz	1 kHz	
		-150		dBc/Hz	10 kHz	
		-158		dBc/Hz	100 kHz	
		-160		dBc/Hz	1 MHz	
Jitter		0.1		ps RMS	@ 12 kHz to 20 MHz	
Weight			2.0	g		
Processing & Packing	Handling & Processing Note					

## Absolute Maximum Ratings

supply voltage (Vs)			6.0	V	with Vs=3.3 VDC
Output Load			50	pF	
Operable Temperature Range	-40		+85	°C	
Storage Temperature Range	-40		+105	°C	

## Typical Performance

### Phase Noise

TX-500 @ 12.8MHz HCMOS

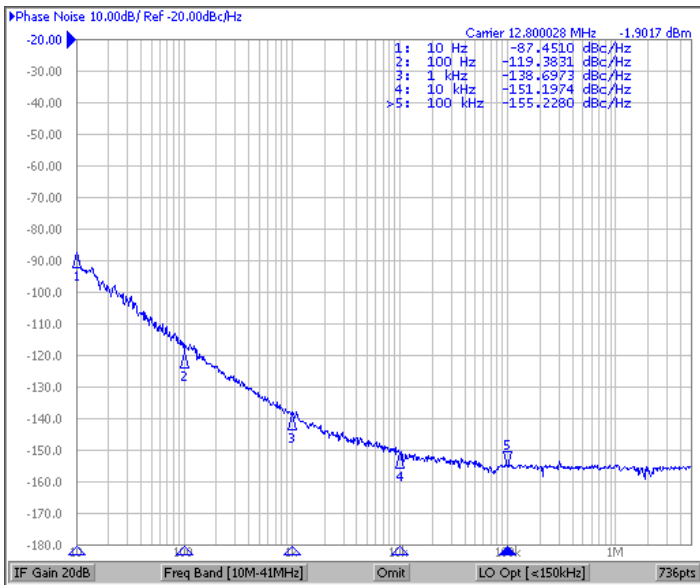

### Phase Noise

TX-500 @ 100MHz HCMOS

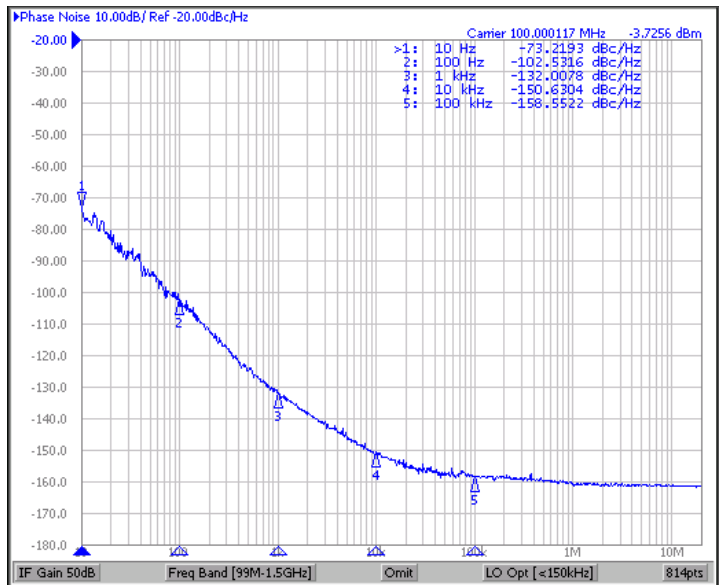

# Outline Drawing / Enclosure

TX-500	
Type	Height "H"
G214B [Standard]	5.9
G214C [Option]	2.8
G286C [Option]	6.1

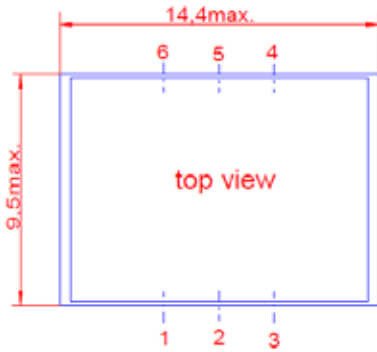

**G 214**  
H = 5,9 : G 214 B  
H = 2,8 : G 214 C  
H = 4,0 : G 214 D

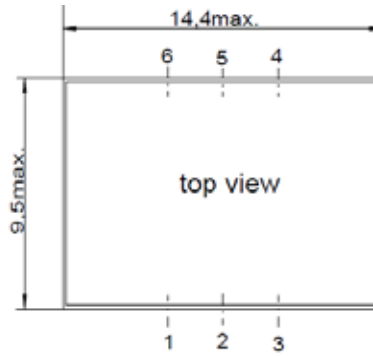

**G 286**  
H = 5,9 : G 286 B  
H = 6,1 : G 286 C

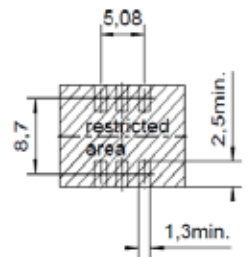
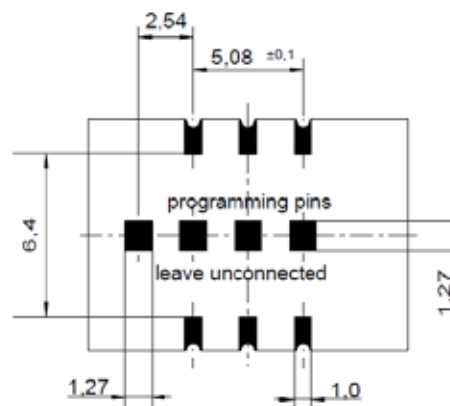
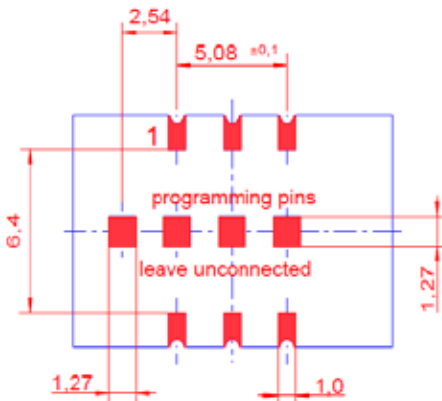
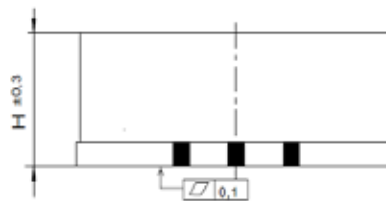
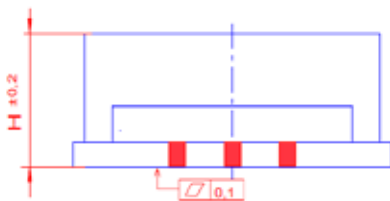

Padvorschlag  
land pattern  
recommendation

Pin Connections (CMOS, Clipped Sinewave, True Sinewave)	
1	Control Voltage Input (Vc) / N.C.
2	N.C.
3	Ground (Case)
4	RF-Output
5	N.C.
6	Supply Voltage Input (Vs)

Pin Connections (PECL)	
1	Control Voltage Input (Vc) / N.C.
2	N.C.
3	Ground (Case)
4	RF-Output
5	RF-Output_complementary
6	Supply Voltage Input (Vs)

## Standard Shipping Method (TX-500)

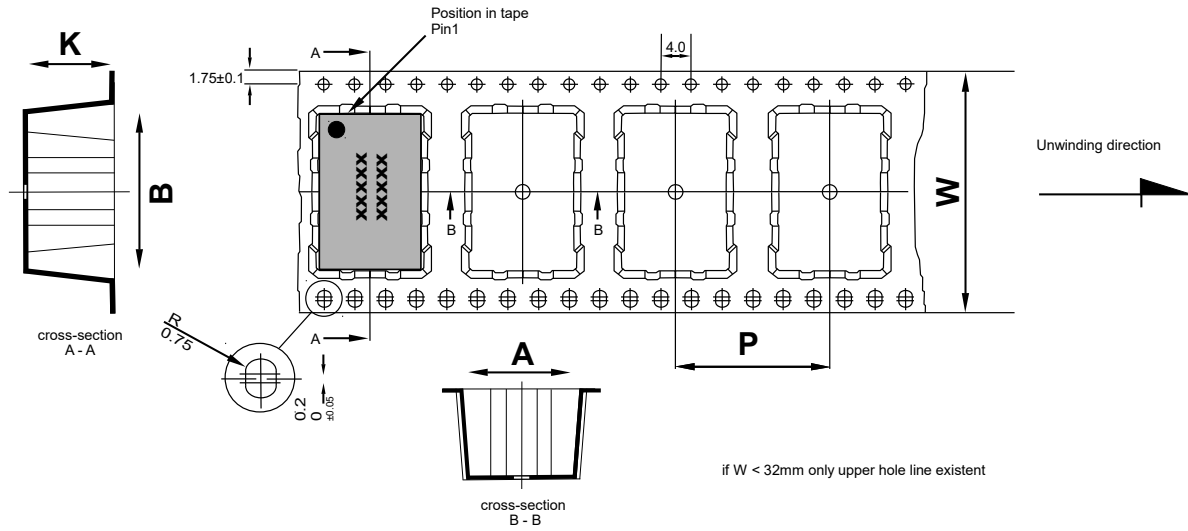

Dimension in mm:  
 A, B and K are dependent upon component dimensions  
 production tolerance complying DIN IEC 286-3

All dimensions in millimeters unless otherwise stated

Enclosure Type	Tape Width W (mm)	Quantity per meter	Quantity per reel	Dimension P
G214B / G286C	24	83.3	850	12
G214C	24	83.3	1700	12

## Recommended Reflow Profile

TP: max 250°C (@ solder joint, customer board level)

T<sub>p</sub>: max: 10...30 sec

Additional Information:

This SMD oscillator has been designed for pick and place reflow soldering

SMD oscillators must be on the top side of the PCB during the reflow process.

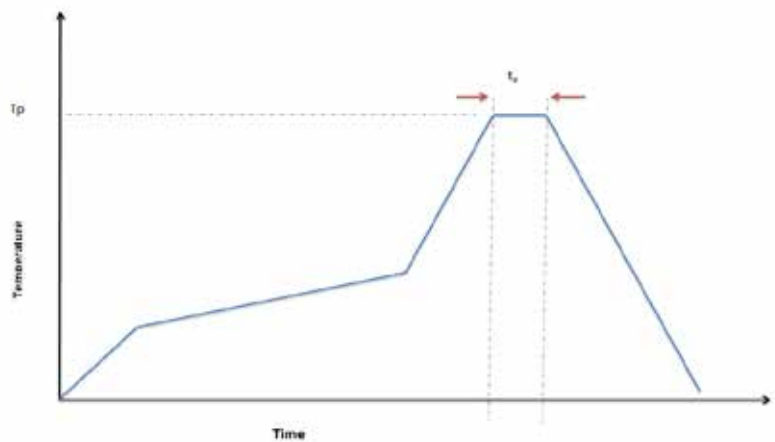

## Ordering Information

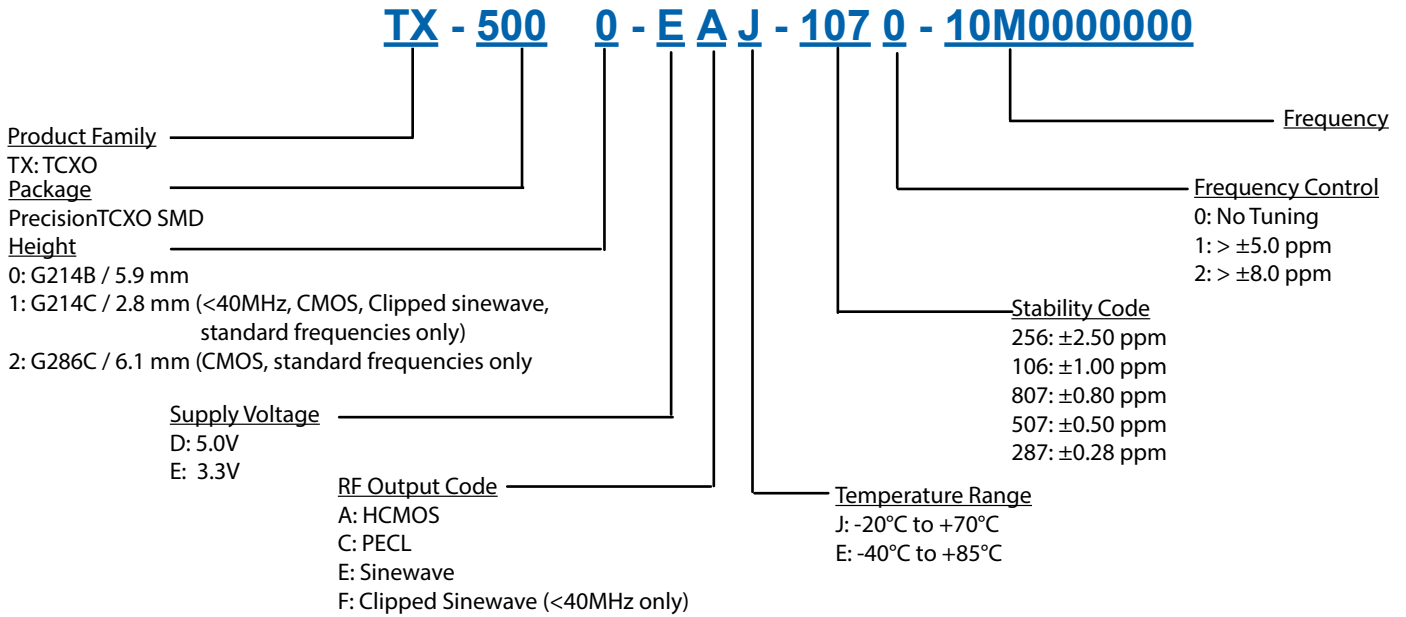

**Notes:**

1. Contact factory for improved stabilities or additional product options. Not all options and codes are available at all frequencies.
2. Phase noise degrades with increasing output frequency.
3. Contact factory for availability.

Unless other stated all values are valid at typical conditions for supply voltage, frequency control voltage, load, temperature (25°C).

Subject to technical modification.



Microsemi, a wholly owned subsidiary of Microchip Technology Inc. (Nasdaq: MCHP) offers a comprehensive portfolio of semiconductor and system solutions for aerospace & defense, communications, data center and industrial markets. Products include high-performance and radiation-hardened analog mixed-signal integrated circuits, FPGAs, SoCs and ASICs; power management products; timing and synchronization devices and precise time solutions, setting the world's standard for time; voice processing devices; RF solutions; discrete components; enterprise storage and communication solutions, security technologies and scalable anti-tamper products; Ethernet solutions; Power-over-Ethernet ICs and midspans; as well as custom design capabilities and services. Learn more at [www.microsemi.com](http://www.microsemi.com).

**Microsemi Headquarters**  
 One Enterprise, Aliso Viejo, CA 92656 USA  
 Within the USA: +1 (800) 713-4113  
 Outside the USA: +1 (949) 380-6100  
 Sales: +1 (949) 380-6136  
 Fax: +1 (949) 215-4996  
 email: [sales.support@microsemi.com](mailto:sales.support@microsemi.com)  
[www.microsemi.com](http://www.microsemi.com)

Microsemi makes no warranty, representation, or guarantee regarding the information contained herein or the suitability of its products and services for any particular purpose, nor does Microsemi assume any liability whatsoever arising out of the application or use of any product or circuit. The products sold hereunder and any other products sold by Microsemi have been subject to limited testing and should not be used in conjunction with mission-critical equipment or applications. Any performance specifications are believed to be reliable but are not verified, and Buyer must conduct and complete all performance and other testing of the products, alone and together with, or installed in, any end-products. Buyer shall not rely on any data and performance specifications or parameters provided by Microsemi. It is the Buyer's responsibility to independently determine suitability of any products and to test and verify the same. The information provided by Microsemi hereunder is provided "as is, where is" and with all faults, and the entire risk associated with such information is entirely with the Buyer. Microsemi does not grant, explicitly or implicitly, to any party any patent rights, licenses, or any other IP rights, whether with regard to such information itself or anything described by such information. Information provided in this document is proprietary to Microsemi, and Microsemi reserves the right to make any changes to the information in this document or to any products and services at any time without notice.

©2018 Microsemi, a wholly owned subsidiary of Microchip Technology Inc. All rights reserved. Microsemi and the Microsemi logo are registered trademarks of Microsemi Corporation. All other trademarks and service marks are the property of their respective owners.