

# Microsemi Mellanox NVMe-oF Collaboration

Feb. 9<sup>th</sup> 2018

# NVMe over Fabrics and Heterogeneous Compute

- Standard NVMe over Fabric forces all IOs through CPU DRAM, putting unnecessary strain on the control plane and CPU
- NVMe over Fabric with **PCIe peer-to-peer (P2P)** allows data IOs to bypass CPU DRAM and flow directly between NIC and NVMe endpoint which is achieved by:
  - Relying on Microsemi NVRAM card with DRAM exposed as a PCIe BAR (or other DRAM PCIe BAR implementations such as CMB)
  - Deploying the new NVMe driver on the target CPU with P2P capability

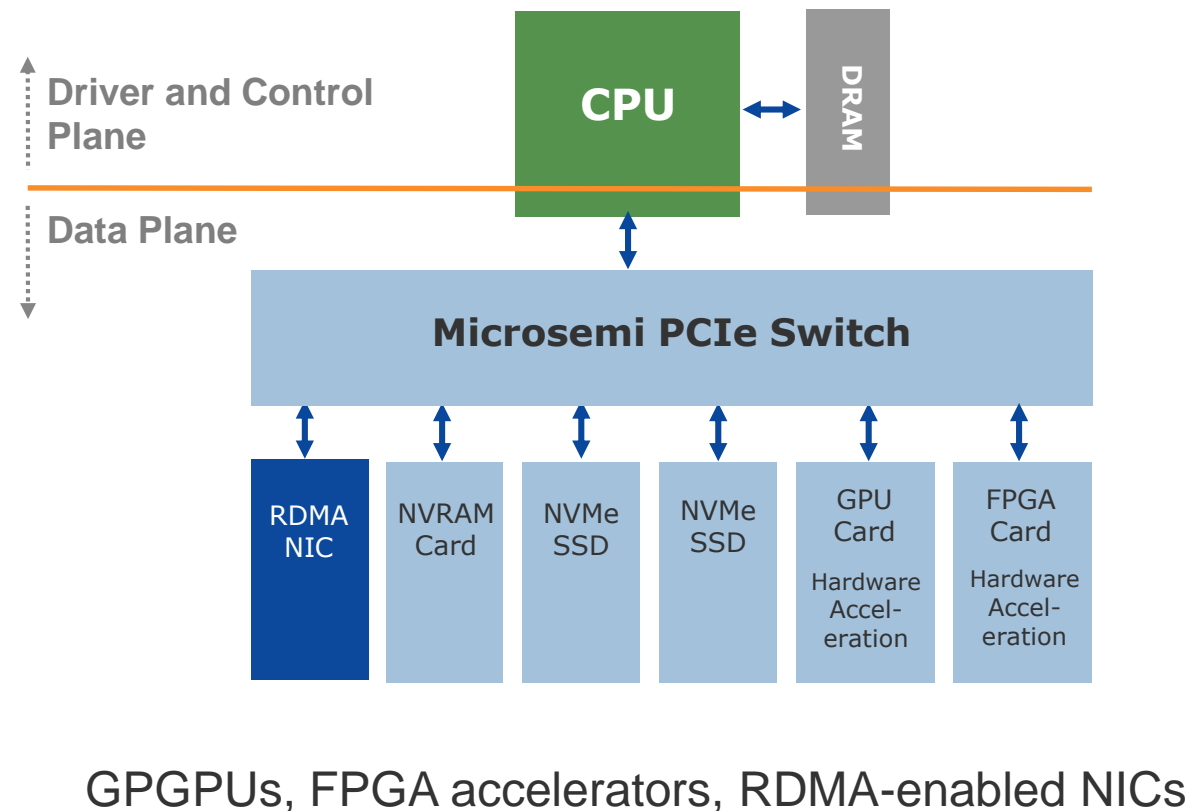

# Demo: What is an FBOF?

# JBOF + Fabric + P2P

## NVMe over **F**abrics attached just a **B**unch **O**f **F**lash

- Start with a PCIe JBOF with Microsemi Switchtec and Flashtec
- Add RDMA NIC
- Add DRAM exposed as PCIe BAR with Microsemi Flashtec
- Add Microsemi P2Pmem NVMe Linux Driver

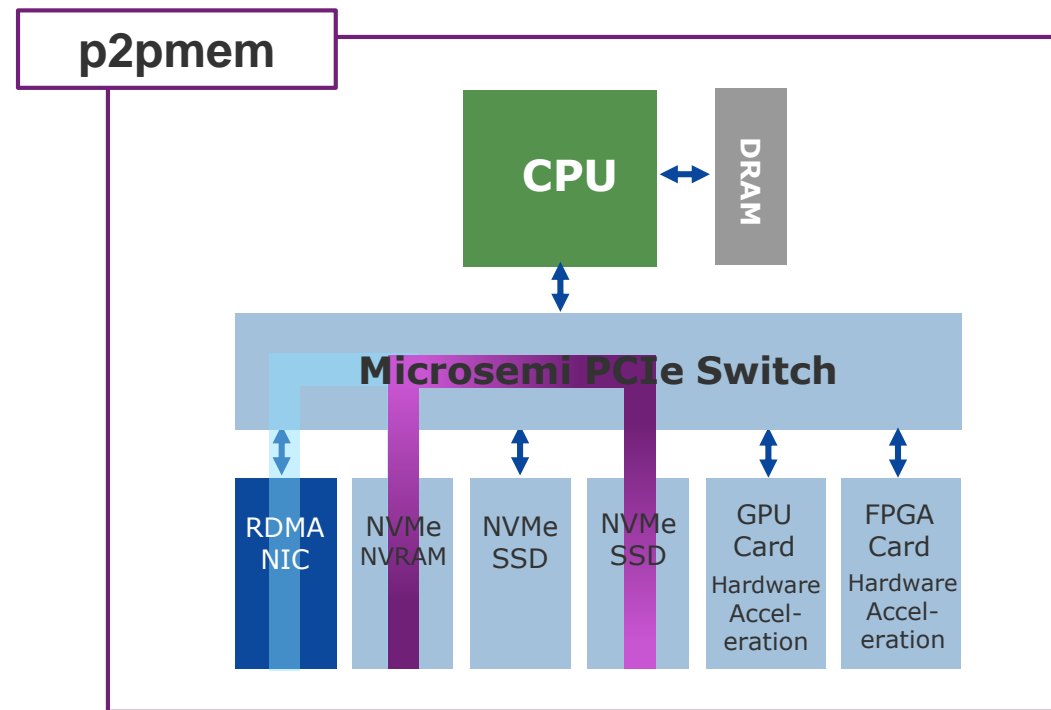
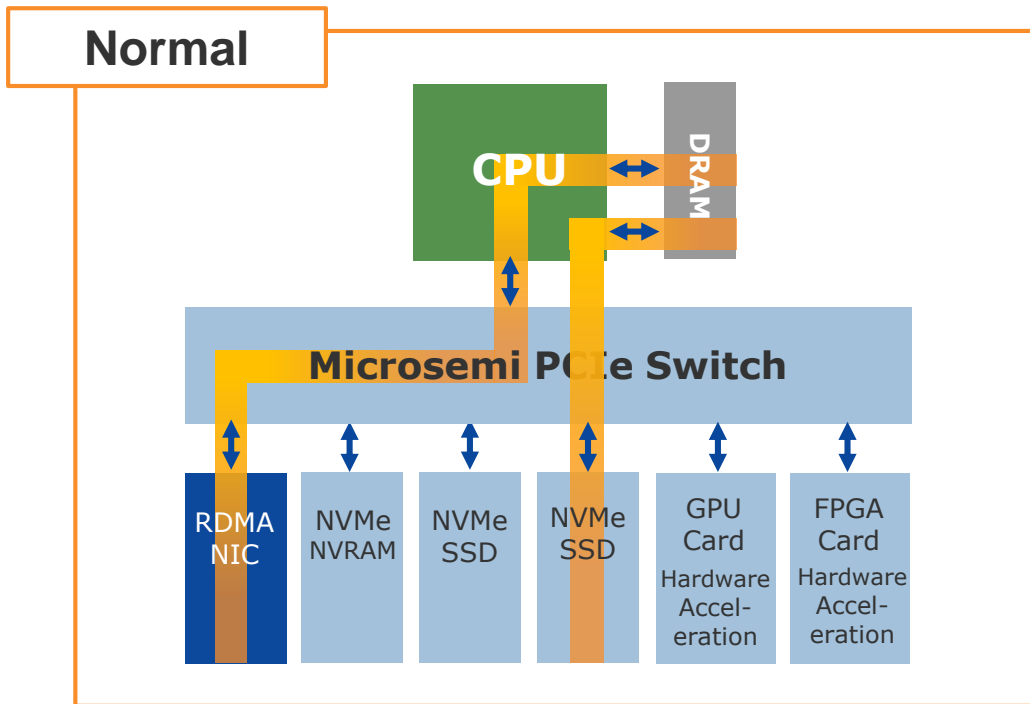
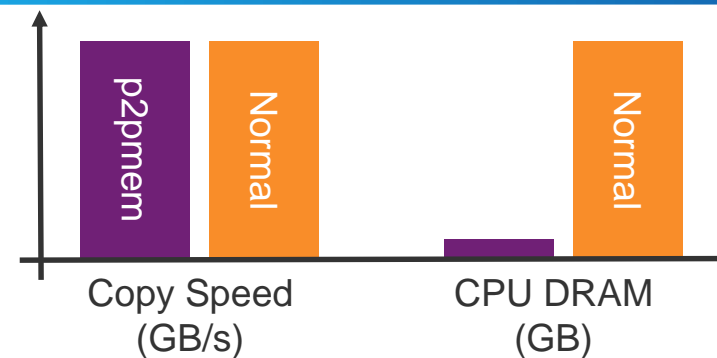

# Example: High Performance FBOF with CPU Offload

Low latency, high bandwidth, optimized data plane

## PCIe Peer to Peer (P2P)

- Bypass CPU DRAM
- High performance data plane
- FBOF implementation

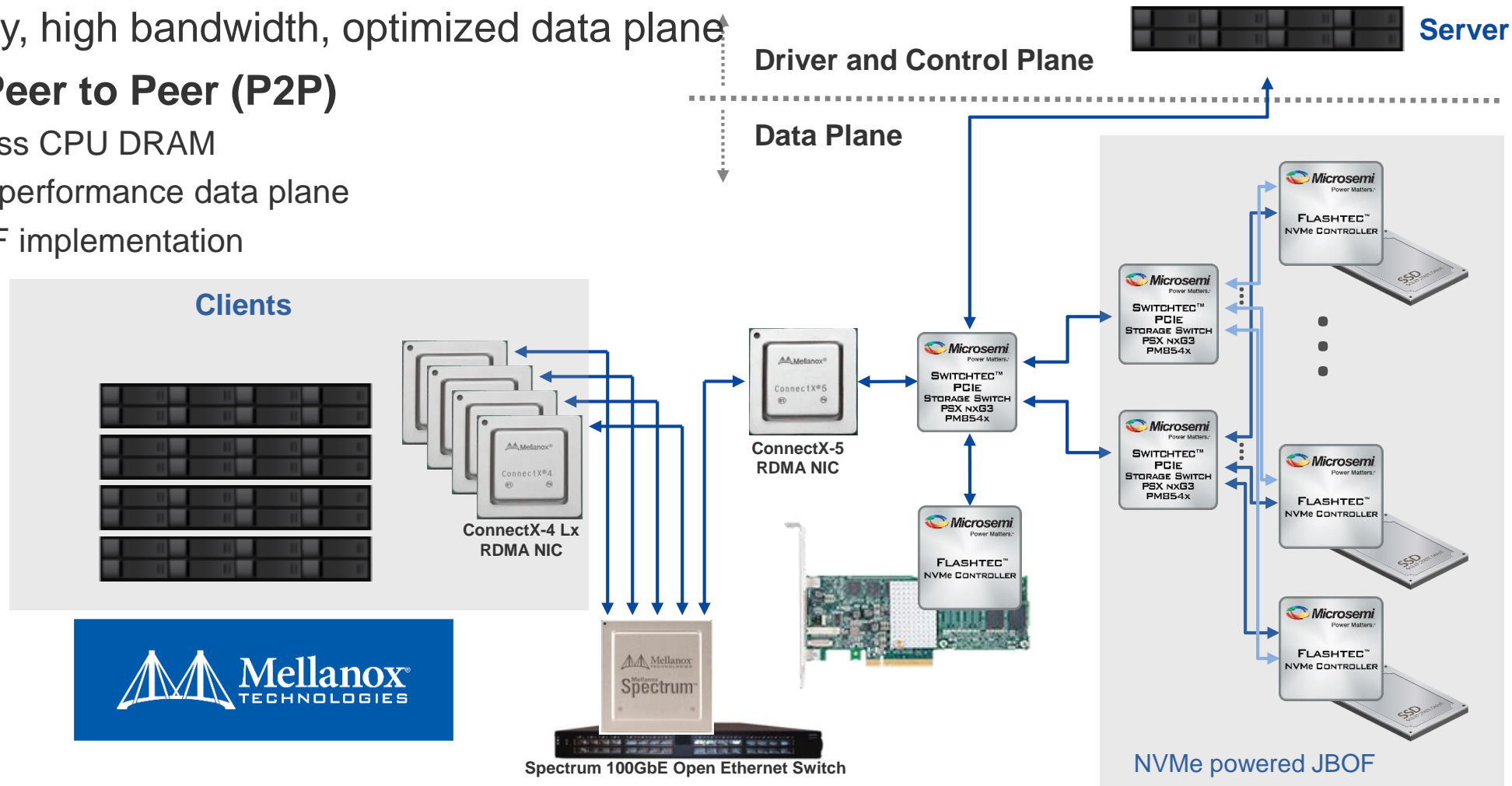

*Microsemi's Switchtec+Flashtec+P2P = Lowest TCO for NVMe-oF Applications*

# Microsemi Mellanox NVMe-oF Collateral

- [NVMe-oF P2PMem Storage Solution Press Release](#)
- NVMe-oF P2PMem FMS Demo Presentation (this slide deck)
- [NVMe-oF P2PMem FMS Demo Video](#)
- [NVMe-oF P2PMem Reference Architecture](#)
- [Accelerating NVMe Innovations FMS 2017 Keynote](#)
- [BlueField Support Press Release](#)

# Thank You!



#### **Microsemi Corporate Headquarters**

One Enterprise, Aliso Viejo, CA 92656 USA

Within the USA: +1 (800) 713-4113

Outside the USA: +1 (949) 380-6100

Sales: +1 (949) 380-6136

Fax: +1 (949) 215-4996

email: [sales.support@microsemi.com](mailto:sales.support@microsemi.com)

[www.microsemi.com](http://www.microsemi.com)

©2018 Microsemi Corporation. All rights reserved. Microsemi and the Microsemi logo are registered trademarks of Microsemi Corporation. All other trademarks and service marks are the property of their respective owners.

Microsemi Corporation (Nasdaq: MSCC) offers a comprehensive portfolio of semiconductor and system solutions for aerospace & defense, communications, data center and industrial markets. Products include high-performance and radiation-hardened analog mixed-signal integrated circuits, FPGAs, SoCs and ASICs; power management products; timing and synchronization devices and precise time solutions, setting the world's standard for time; voice processing devices; RF solutions; discrete components; enterprise storage and communication solutions, security technologies and scalable anti-tamper products; Ethernet solutions; Power-over-Ethernet ICs and midspans; as well as custom design capabilities and services. Microsemi is headquartered in Aliso Viejo, Calif., and has approximately 4,800 employees globally. Learn more at [www.microsemi.com](http://www.microsemi.com)

Microsemi makes no warranty, representation, or guarantee regarding the information contained herein or the suitability of its products and services for any particular purpose, nor does Microsemi assume any liability whatsoever arising out of the application or use of any product or circuit. The products sold hereunder and any other products sold by Microsemi have been subject to limited testing and should not be used in conjunction with mission-critical equipment or applications. Any performance specifications are believed to be reliable but are not verified, and Buyer must conduct and complete all performance and other testing of the products, alone and together with, or installed in, any end-products. Buyer shall not rely on any data and performance specifications or parameters provided by Microsemi. It is the Buyer's responsibility to independently determine suitability of any products and to test and verify the same. The information provided by Microsemi hereunder is provided "as is, where is" and with all faults, and the entire risk associated with such information is entirely with the Buyer. Microsemi does not grant, explicitly or implicitly, to any party any patent rights, licenses, or any other IP rights, whether with regard to such information itself or anything described by such information. Information provided in this document is proprietary to Microsemi, and Microsemi reserves the right to make any changes to the information in this document or to any products and services at any time without notice.