



SPACE BRIEF

[Newsletter Archive](#) | [Feedback](#) | [Microsemi](#)

Articles in this Edition:

- [Recent Product News](#)
- [Product Updates and Notifications](#)
- [Space News](#)
- [Special Feature](#)
- [Microsemi's Commitment to Space](#)
- [Appearances and Events](#)
- [Register to Receive the Microsemi Space Brief](#)

Welcome to this special edition of Microsemi's Space Brief quarterly newsletter Edition 19, featuring our unique Space Forum 2017 series of global technical conferences. This Space Brief has a comprehensive agenda of upcoming Microsemi Space Forum events that includes details of our partner participation. This edition also includes news about the expansion of our Space portfolio with radiation-tolerant analog mixed-signal ICs for telemetry and motor control, as well as our next-generation RTG4™ FPGA family, while also discussing challenges for New Space and Microsemi's satellite timing module. We will highlight the upcoming space events Microsemi will attend, and we look forward to seeing you there.

We hope you find our newsletter useful and encourage you to share this edition with your colleagues. Instructions on how to subscribe to our quarterly Space Brief are included at the end of the newsletter.

Recent Product News

RTG4 Qualified Space Flight FPGAs Now Shipping



Since RTG4 high-speed radiation-tolerant FPGAs achieved MIL-STD-883 Class B qualification towards the end of 2016, we have been shipping qualified space flight units in various screening flows including B flow, Extended flow (E flow), and EV flow. The Microsemi EV flow includes all screening and processing steps equivalent to the QML Class V as per MIL-PRF-38535. The EV flow is available until QML Class V qualification completion, estimated to be early 2018.

To achieve the MIL-STD-883 Class B qualification, the RTG4 FPGAs passed a series of environmental tests to determine resistance to the deleterious effects of exposure to the elements and conditions surrounding defense and space operations, as well as mechanical and electrical tests. RTG4 units from multiple wafer lots passed 1,000-hour high-temperature life tests as required by MIL-STD-883 Class B. The qualification units have been given additional life tests, and as of now have passed the 2,000-hour high-temperature life test, proving the high reliability of RTG4 flash cells in extreme conditions. Microsemi is committed to providing high-quality and reliable solutions for our customers to meet the increasing demands of modern satellite systems.

Introducing New CQ352 Package for RTG4 FPGAs

A ceramic quad flat pack (CQFP) package with 352 pins was recently introduced for the RTG4 FPGAs family to provide a more cost-effective integration than higher pin count packages. CQFP is the industry-standard package for space applications with well-established board integration and inspection procedures. The RTG4 device in a CQ352 package features four embedded SpaceWire clock and data recovery circuits, and four high-speed serialization/deserialization (SerDes) transceivers that can be used for either native EPCS or PCIE protocols while maintaining the same count of LUTs, flip-flops, DSP math blocks, and SRAM blocks as the existing ceramic column grid array (CCGA) package with 1657 pins.



The RTG4 device in a CQ352 package is now available in the Libero SoC v11.7 SP3 and later software tool set, allowing customers to design with this new device package combination. Customers are recommended to download the latest version of [Libero SoC software](#). The first RTG4 CQ352 samples are expected in late summer 2017, followed by B-flow space flight units in late 2017. To learn more about RTG4 device in CQ352 package, please see the recently updated [RTG4 Product Brief](#).

RISC-V Processor Support for RTG4 FPGAs

Microsemi is the first FPGA provider to offer a comprehensive software tool chain and intellectual property (IP) core for RISC-V designs. Our RV32IM RISC-V core is currently available for RTG4 FPGAs, IGLOO2 FPGAs and SmartFusion2 system-on-chip (SoC) FPGAs, and with an Eclipse-based SoftConsole integrated development environment (IDE) with Libero SoC Design Suite.



The new RV32IM RISC-V core lets customers design with an open instruction set architecture (ISA), enabling complete portability and a more secure processor architecture governed by a permissive BSD license. Engineers can now rely on an open ISA and leverage open-source tools and hardware without being tied to a single vendor. Never before has a processor allowed designers to inspect, modify, adapt, collaborate, and migrate their design to the best platform for their product. This core is especially useful for high-reliability applications, as the register transfer level (RTL) source code is available for inspection. A reference design targeting the RTG4 development kit is now available on the RISC-V GitHub website. To learn more about RISC-V, please visit <https://www.microsemi.com/products/fpga-soc/soc-processors/risc-v>.

For more information on RT FPGAs, please contact minh.u.nguyen@microsemi.com



Minh U. Nguyen
Marketing Manager, Space FPGAs, SoC Products Group

Product Updates and Notifications

Space System Manager Availability Update



The LX7730 Radiation-Tolerant Telemetry Controller has successfully completed qualification testing. Qualification testing required Class V flow, which included a 4,000-hour life test that was completed in March. Testing for Class Q flow is planned for completion in June 2017. We are seeking QML certification for both flows, and plan to achieve that later this year. We are currently accepting orders for flight-qualified products for both flows. In addition, we also offer an LX7730-DB daughter board that can interface with our currently available RTG4 development board.

The LX7720 Radiation-Tolerant Motor Control/Position Sensing IC is currently sampling with errata. Final silicon will be available for sampling this fall. The LX7720-DB daughter board will also be available. Full details for the availability of the LX7720, LX7730, and related development tools can be found on our website at https://www.microsemi.com/document-portal/doc_download/136027-ssm-availability.

Microsemi Achieves QML Certifications for Radiation-Tolerant Diode Array

The LX7710 Radiation-Tolerant 8-pair Diode Array has been listed on the Qualified Manufacturers List (QML) for Class V and Class Q qualifications from the Defense Logistics Agency (DLA) Land and Maritime. The listings indicate the LX7710 has achieved the highest level of criterion for space-level products. The devices must be able to pass the stringent technology conformance inspection (TCI) tests required in the MIL-PRF-38535 performance specification. This eliminates the need for customers to perform these tests, providing



scheduling and cost benefits. The QML qualification achievement allows designers across the entire spectrum of space designs, from low-cost commercial and scientific applications to human-rated and top-priority government systems, to use the parts without cumbersome part selection justifications or source control drawings.

The SMD numbers are 5962-1621001QXC for QML-Q and 5962-1621001VXC for QML-V. The complete datasheet and other information can be found on our website at <https://www.microsemi.com/existing-parts/parts/136653>.

Don't forget that we also offer an 8-Channel Radiation Tolerant High Side Driver, the AAHS298B, that also has a QML-V and QML-Q listing. Check out its datasheet and supporting information at www.microsemi.com/existing-parts/parts/35

For more information, contact Dorian Johnson at Dorian.Johnson@microsemi.com with any questions.



Dorian Johnson

Product Marketing Manager, Analog Mixed Signal High-Reliability ICs

Space News

New Space



Large-scale satellite constellations are currently a big focus in the small satellite community, as they allow for faster technology introduction and cost savings. The ideal application for this type of constellation is telecommunications that provide worldwide broadband internet to many countries. The current approach by many companies is to trade traditional component-level reliability with system-level reliability. In other words, they are looking to launch a very large satellite constellation based on the assumption that several satellites will fail during the operational period; the backup satellites already in orbit will ensure that the overall constellation keeps functioning.

Unfortunately, even with this approach, there still exists a very real radiation risk to large-scale semiconductor failure on orbit, which prohibits an all-COTs type of approach. However, a carefully selected combination of high-reliability COTs and traditional radiation-hardened-by-design semiconductors coupled with a good fault-tolerant architecture could provide an optimal solution.

The target orbit for these types of constellations is low Earth orbit (LEO) at a very high 80°-90° inclination to provide ideal communication coverage while maximizing launch cost savings. The challenge is that this orbit will drive stringent single-event effects (SEE) requirements on the satellite (upwards of 65 MeV) that cannot be met by many COTs components. Total ionization dose (TID) effects will also be a concern to the system architect, but are not as critical due to the short 3-5 year mission requirement.

When it comes to SEE, system designers are concerned with both destructive and non-destructive events. Destructive SEE consists of events such as single-event gate rupture (SEGR), single-event burnout (SEB), and single-event latch-up (SEL). Non-destructive SEE includes events such as single-event transients (SET), multi-bit upsets (MBU), single-event functional interrupts (SEFI), and single-bit upsets (SBU). The satellite design architect must be very familiar with each device in the architecture and the potential destructive and non-destructive failure modes.

The distributed power architecture of the satellite is perhaps one of the most critical points of the architecture because if the power supply fails, the satellite cannot function. In addition, power devices ([MOSFETs](#), [Shockey Diodes](#), and so on) are among the devices most susceptible to SEEs. In addition to the traditional destructive events, power architectures are also prone to high-voltage transients (SETs), which can be destructive to both downstream power devices as well as digital electronics. Power architectures are also often repeated throughout the satellite with the same components. This means the failure rate of the power electronics due to SEE can become exponentially higher at the satellite level, leading to the potential of a complete constellation failure due to poor power supply design and component selection process.

Microsemi's heritage in the space market, coupled with our broad portfolio of space electronics, makes our team an ideal partner for solving the challenges facing New Space. Visit our Space webpage at www.microsemi.com/applications/space.

For more information, contact Chris Hart at Chris.Hart@microsemi.com with any questions.



Chris Hart

Aerospace Director, Discrete Products Group (DPG)

Microsemi Satellite Timing Module for Next-Generation Satellite Bus

Precision frequency sources are required for timekeeping and metrology in communication and navigation satellites. The frequency sources for these satellites are typically quartz oscillators and, in rare instances when absolute accuracy is required, atomic clocks. Frequency sources can be used to establish a time base for each satellite or groups of satellites, typically with ground station support. All frequency sources are subject to change over time, usually referred to as "drift" or "aging". Therefore, the frequency and time must be adjusted remotely, a process that takes effort and often impacts the accuracy of the local time. Autonomous and accurate local frequency and time for individual or constellations of satellites provide a significant improvement in the current system's capabilities.

The availability of time by means of GNSS allows for adjustment of a system's local time by means of one pulse per second (1 PPS) and delivered time of day information provided in the constellations. The use of Kalman filtering to steer high-performance crystal oscillators provides high accuracy and stability while maintaining the long-term performance of the GNSS on-board atomic clocks. Microsemi has developed a space-borne product that leverages heritage space ovenized oscillators and advanced Kalman filter algorithms to demonstrate exceptional performance for 1 PPS steered and un-steered conditions.

For more information about Microsemi's Satellite Timing Module, please contact Ashley Pollock at ashley.pollock@microsemi.com.

Ashley Pollock

Business Development Manager, Frequency and Time Division



Special Feature

In past editions of our Space Brief, we have introduced a customer perspective section to our newsletter. This was positively received in the Space market, and due to the favorable response we have decided to extend this feature to our partner companies. We would like to thank Cobham Gaisler and Blue Pearl Software for contributing to this issue of Space Brief. If you are interested in contributing to our newsletter or writing an article, contact SpaceBrief@microsemi.com.

Leon3 and Leon4 Processor Support for RTG4 FPGAs

Do you already own the Microsemi [RTG4 development kit](#) or plan to procure and use it with a processor IP? It has never been easier to learn about and evaluate processors on space-grade FPGAs than it is today. Cobham Gaisler, provider of the well-known LEON3 and LEON4 SPARC V8 processors, offers free downloads of programming bitfiles of multi-core LEON systems for the RTG4 development kit for evaluation purposes on their website.

LEON3 and LEON4 designs are supplied as both multi-core and containing several on-chip peripherals, such as interrupt controllers, timers, GPIO, and more. Access to the on-board SPI flash is provided through an SPI memory controller attached to the AHB processor bus. The AHB bus is connected to the FDDR DDR3 SDRAM controller of the RTG4 FPGA through a bridge. LEON4 systems implement a level-2 cache between the AHB bus and the FDDR memory controller. The designs do not implement fault tolerance and can only be used on the RTG4 development kit. Both the ES and PROTO versions of the kit are supported. The Cobham Gaisler GRMON2 debug tool, which is commonly required for development with LEON systems, supports the bitstream evaluation even in the free 21-day evaluation version.

The Cobham Gaisler IP-core library (GRLIB) provides full support for RTG4 technology. Centered around the LEON3FT and LEON4FT processors, GRLIB currently contains well over 100 cores, including interfaces such as SpaceWire, PCI, MIL-STD-1553, Ethernet, CAN, and more. Technology mapping, simulation, synthesis script

generation, vendor tool integration, and board-specific template designs allow developers a fast and easy way to start their design and provide a route to rapid design cycles.

For more information, visit <http://www.gaisler.com>
LEON-RTG4 Bitfiles download: <http://gaisler.com/LEON-RTG4>
GRMON2 evaluation version download: <http://gaisler.com/GRMON>

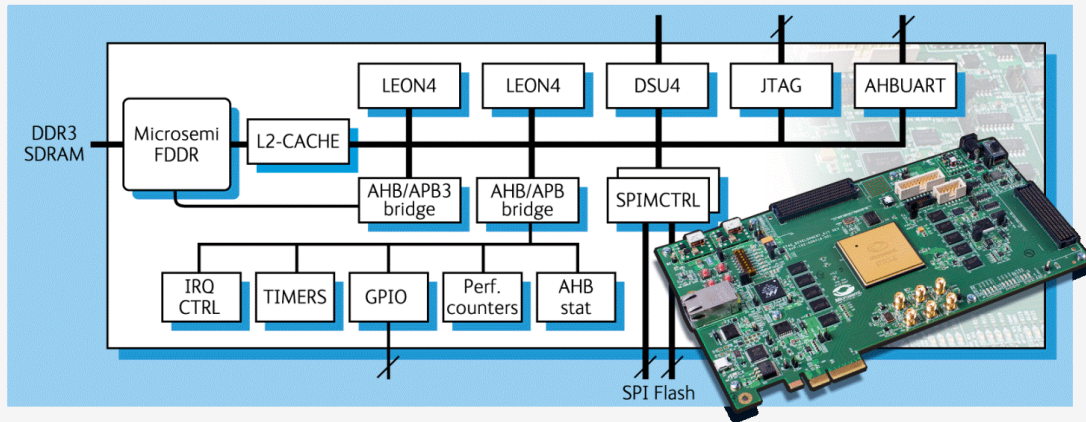

Christian Sayer
Field Applications Engineer, Cobham Gaisler



Blue Pearl Software Collaborates with Microsemi to Accelerate FPGA Verification for Military and Aerospace Designs



Blue Pearl Software, a leading provider of design automation software for ASIC, FPGA, and IP RTL verification, has partnered with Microsemi Corporation to streamline RTL design and verification. The Visual Verification Suite now offers advanced RTL linting, Clock Domain Crossing (CDC) analysis, and automated Synopsys Design Constraints (SDC) generation for Microsemi's radiation-tolerant FPGAs.

When used in combination with Microsemi's Libero Design Suite, the Visual Verification Suite provides designers a comprehensive, easy-to-use RTL verification solution that analyzes clocks structures, resets, finite state machines, counters, levels of logic, and coding style conformance. The solution also includes a DO-254 verification package specifically targeting complex electronic hardware in airborne systems.

The Visual Verification Suite's CDC analysis extends the capabilities provided in Libero's SmartTime by analyzing for metastability caused by CDC issues prior to synthesis. The SDC option automates the generation of simulation assertions and synthesis constraints for multicycle and false paths detected in VHDL, Verilog, or System Verilog.

Additional Information

For more information regarding how you can accelerate your RTL verification with Visual Verification Suite, visit Blue Pearl's website at www.bluepearlsoftware.com.

Scott Bloom
Chief Technology Officer at Blue Pearl Software

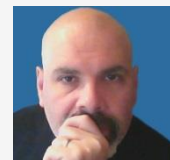

North America

May 18th 2017
Online Event

Europe

June 20th 2017
Radisson Blu Palace Hotel
Noordwijk, Netherlands

India

July 25th 2017
The Leela Palace
Bangalore, India

India

July 27th 2017
Courtyard Marriott
Ahmedabad, India

Join Us for Space Forum 2017

Please plan on joining Microsemi for our biannual one-day technology forum! Microsemi's technical experts and partners will present the most innovative space-related products, capabilities, and technology roadmaps, as well as solutions for combating the effects of radiation, and much more. We will provide demonstrations of the latest products from Microsemi and our partners.

This is a must-attend Space technology forum for system-level architects, R&D engineers, design and component engineers, and other Space industry professionals. Feel free to share this information with your Space-technology colleagues.

There will be one highly educational informative track following the welcome address. Please note your preferred location when you register online.

Space Forum Agenda

Introduction and Welcome Address

RT FPGA Product Update

RT FPGA Radiation Characterization

Space Power and Point of Load Solutions Product Overview

RTG4 Power Hardware Reference Design

High Precision Frequency and Timing Solutions for Space

Mixed Signal Solutions for Space

Achieving Timing Closure for Maximum Performance in RTG4 FPGAs

Next Generation Power Discretes

Space Application Focus

Microsemi and Partner Product Demonstrations

Throughout the day we will provide a series of demonstrations of Microsemi radiation-tolerant products, including a telemetry solution using an RTG4 FPGA and an LX7730 Telemetry Manager, a motor control solution using an RTG4 FPGA and an LX7720 Motor Control Manager, a power supply design using an SA50 DC-DC converter, MHP8564 and MHP8565 point of load regulators, and an in-system reprogramming solution for an RTG4 FPGA using an RISC-V microprocessor integrated into a second RTG4 FPGA.

Our partners will demonstrate data networking using SpaceWire and SpaceFiber protocols, space-rated DDR2 and QDR-II+ memory products operating with RTG4 FPGAs, LEON3FT, and LEON4FT microprocessor IPs operating in an RTG4 FPGA, and a software tool for analysis of clock-domain crossings in RT ProASIC3 and RTG4 FPGAs, while also demonstrating wafer and bare die components.

[Click here](#) to view the Space Forum agenda online.

These will be invitation-only events and unfortunately there will be a limited number of places available in each location, so we encourage all our valued customers to register early. To learn more about Space Forum 2017, visit www.microsemi.com/spaceforum. We look forward to seeing you there!

Registration is now live. To register, visit www.microsemi.com/microsemi-space-forum-register-now.

For more information, email Sylvia Keane at sylvia.keane@microsemi.com



Microsemi
SPACE FORUM

Register Now ▶

Thank you to this year's Partners for joining our 2017 Space Forum.



Appearances and Events

Space Parts Working Group (SPWG)

[The Space Parts Working Group](#) (SPWG) event was held April 4th and 5th in Torrance, CA. It was sponsored by The Aerospace Corporation in cooperation with the U.S. Air Force Space and Missile Systems Center and the National Reconnaissance Office. Now in its 46th year, SPWG is an unclassified, international forum that provides information to the aerospace industry to resolve problems with high-reliability electronic piece parts for space applications.

Space Parts Working Group



Microsemi's key speakers during the event were Chris Hart (Director of Marketing, Aerospace Products, DPG) and Ken O'Neill (Director of Marketing, Space and Aviation, ICSG). In addition to reinforcing our Microsemi space heritage and capabilities, they also discussed the latest news about our Power hybrids and discretes, our RTG4 FPGA qualification, and the LX7730 Telemetry Controller and Space-Qualified Oscillators in our Space Systems Manager, while also reminding everyone of our upcoming Space Forums. We would like to take this opportunity to thank those of you who joined us in our well-attended sponsored luncheon during the Space Parts Working Group event. To view our Microsemi paper presented at the conference, [please click here](#).

Hardened Electronics and Radiation Technology (HEART)

Microsemi participated in the Hardened Electronics and Radiation Technology (HEART) conference at booth 303 in Denver, Colorado, on April 24-28 this year. HEART provides a professional forum specifically for classified research and development investigations. The concentration is on research and development in space radiation and solid-state physics. For further information, visit www.heart-conference.org.



Space Power Workshop

Microsemi was a featured speaker at the [Space Power Workshop](#), held in Manhattan Beach, California, on April 24-27, 2017. Pat Franks, Director of Engineering at Microsemi, explained the Aviation Standard Module Program and the evolution of a Space Launcher. The paper was titled "**Aviation Actuation Electronics for Space Launch Application.**" Please address any questions regarding the paper to Pat Franks at Patrick.Franks@microsemi.com. Kent Brooten, Tactical Marketing Engineer at Microsemi, also presented a paper titled "**Heritage Power Supply Design with New Technology.**" For further information about the paper, please contact Kent Brooten at Kent.Brooten@microsemi.com.

Space Power Workshop



SEE Symposium and MAPLD

Microsemi will be participating in the Single Event Effects (SEE) Symposium and the Military and Aerospace Programmable Logic Devices (MAPLD) Workshop in San Diego, California, on May 22-25, 2017. Microsemi will be exhibiting at booth 3, and representatives will be available during exhibition hours to provide information about Microsemi's solutions. We will also be presenting the following papers: "**Neutron and Heavy Ion SEE testing of Microsemi SmartFusion2 FPGA**" presented by Nadia Rezzak, "**Single Event Induced VT Shift in Flash Cells of Flash-Based FPGA**" presented by J. J. Wang, and "**Single Event Effects Hardening and Testing on Mixed Signal Telemetry LX7730 Controller**" presented by Kathy Zhang. For more information, visit www.seemapld.org.

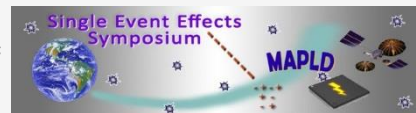

IEEE Nuclear and Space Radiation Effects Conference (NSREC)

Microsemi will be participating in the [IEEE's Nuclear and Space Radiation Effects Conference \(NSREC\)](#), held in New Orleans July 17-21, 2017. Microsemi will be exhibiting at booth 306, where we will be able to meet with many global industry experts and provide information about our products. We will also present the following papers during the conference: "**Investigation of TID and Dynamic Burn-In Induced VT Shift on RTG4 Flash-Based FPGA**" presented by Nadia Rezzak and "**TID, ELDRS, and SEE Hardening and Testing on LX7730 Mixed Signal Telemetry Controller**" presented by Mathieu Sureau.



Register to Receive the Microsemi *Space Brief*

If you enjoyed reading this Space Brief, you can register to receive your own personal copy, delivered directly to your inbox. To register, visit this [link](#). To view past issues, visit our archive at www.microsemi.com/spaceforum/space-brief-newsletter.

For more information on how Microsemi is serving the space market, access our brochure at [Microsemi Space Solutions Brochure](#) and our space webpage at www.microsemi.com/applications/space.

If you have any feedback or content suggestions for the Space Brief Newsletter, send an email to SpaceBrief@microsemi.com or click on the "Feedback" link above. Thank you for your assistance in ensuring Space Brief continues to serve the space market and all employees.

Sylvia Keane

Senior Marketing and Communications Specialist (DPG) and Space Brief Editor-in-Chief

